



# DW03101

## User Manual

- EN
- D
- F
- I
- ES
- PT
- NL
- DK**
- SE
- FIN
- NO
- GR
- TR

[www.dewalt.eu](http://www.dewalt.eu)

Please read these instructions before operating the product.



# Table of Contents

<b>Instrument Set-up</b> .....	<b>2</b>
Introduction- .....	2
Overview .....	2
Display .....	3
Insert batteries .....	3
<b>Operations</b> .....	<b>4</b>
Switching ON/OFF .....	4
Clear .....	4
Message Codes .....	4
Adjusting measuring reference / tripod .....	4
Multifunctional endpiece- .....	5
Distance unit setting .....	5
Tilt unit setting- .....	5
Timer (automatic release) .....	5
Beep ON/OFF- .....	6
Illumination ON/OFF .....	6
<b>Measuring Functions</b> .....	<b>7</b>
Measuring single distance .....	7
Permanent / Minimum-Maximum measuring .....	7
Add / Subtract .....	7
Area .....	8
Volume .....	9
Triangular area .....	10
Pythagoras (2-point) .....	11
Pythagoras (3-point) .....	11
Pythagoras (partial height) .....	12
Stake out .....	13
Smart Horizontal Mode .....	13
Height tracking .....	14
Leveling .....	14
Memory (20 last displays) .....	15

Delete Memory .....	15
---------------------	----

## **Calibration** .....

Calibration of tilt sensor (Tilt Calibration) .....	16
---	----

## **Technical Data** .....

## **Message Codes** .....

## **Care** .....

## **Warranty** .....

## **Safety Instructions** .....

Areas of responsibility .....	18
Permitted use .....	19
Prohibited use .....	19
Hazards in use .....	19
Limits of use .....	19
Disposal .....	19
Electromagnetic Compatibility (EMC)- .....	19
FCC statement (applicable in U.S.) .....	20
Laser classification- .....	20
Labelling .....	20

# Instrument Set-up

## Introduction

 The safety instructions and the user manual should be read through carefully before the product is used for the first time.

 The person responsible for the product must ensure that all users understand these directions and adhere to them.

The symbols used have the following meanings:

### WARNING

Indicates a potentially hazardous situation or an unintended use which, if not avoided, will result in death or serious injury.

### CAUTION

Indicates a potentially hazardous situation or an unintended use which, if not avoided, may result in minor injury and/or appreciable material, financial and environmental damage.

 Important paragraphs which must be adhered to in practice as they enable the product to be used in a technically correct and efficient manner.

## Overview

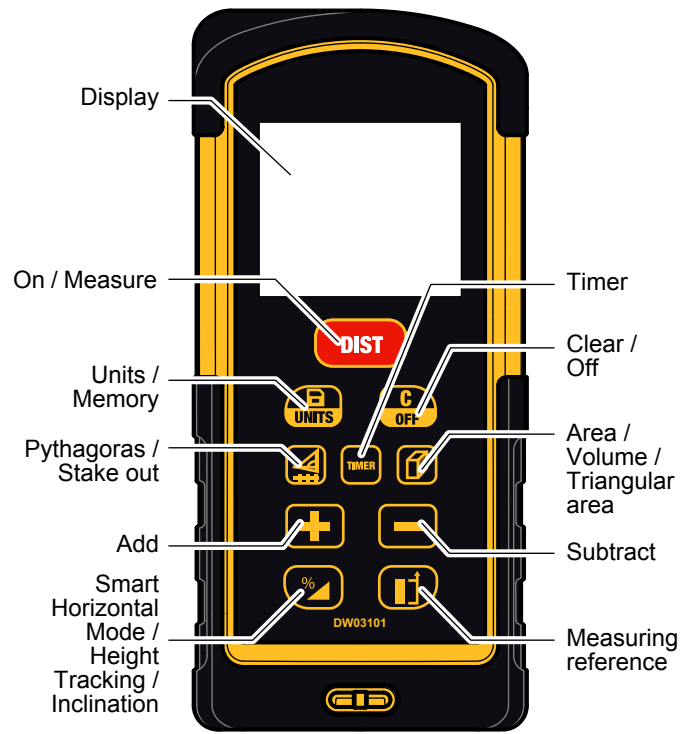

# Instrument Set-up

## Display

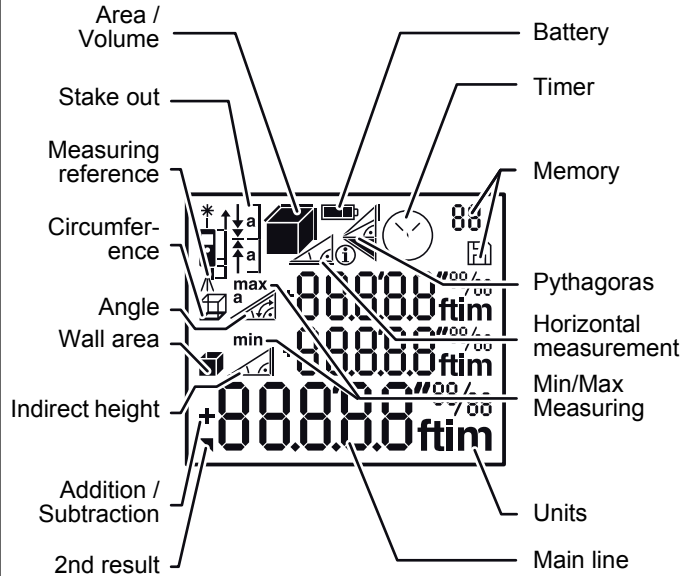

## Insert batteries

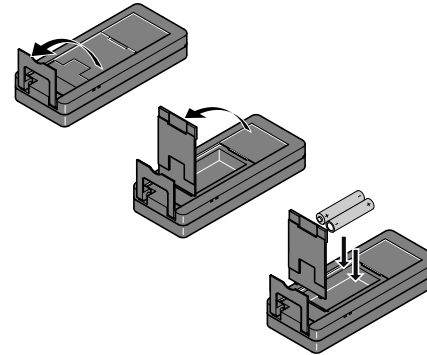

i

To ensure a reliable use, do not use zinc-carbon batteries. Change batteries when battery symbol is flashing.

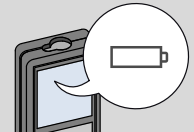

# Operations

## Switching ON/OFF



i

Press ON button 2 sec to start continuous laser mode. If no key is pressed for 180 sec, the device switches off automatically.

## Clear

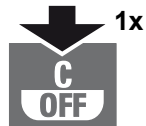

Undo last action.

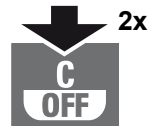

Leave actual function, go to default operation mode.

## Message Codes

If the info icon appears with a number, observe the instructions in section "Message Codes". Example:



## Adjusting measuring reference / tripod

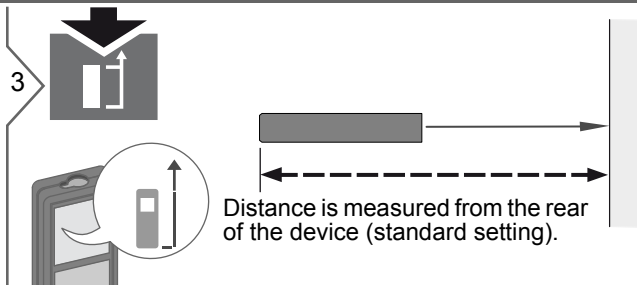
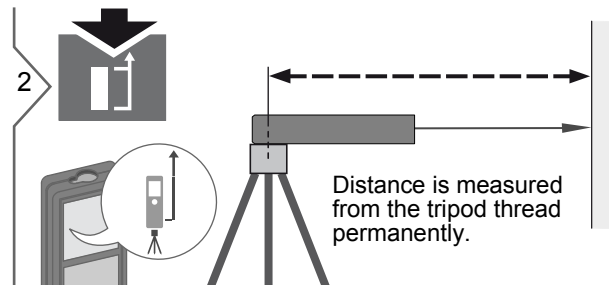
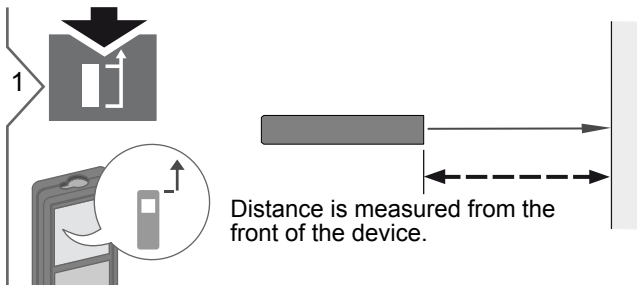

## Operations

### Multifunctional endpiece

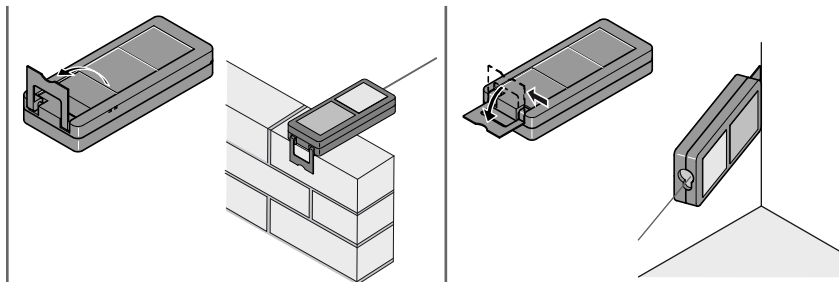

**i** The orientation of the endpiece is automatically detected and the zero point is accordingly adjusted.

### Distance unit setting



2 sec

Switch between the following units:

0.000 m	0.00 ft
0.0000 m	0'00" 1/32
0.00 m	0.00 in
	0 in 1/32

### Tilt unit setting



2 sec  
simultaneously

Switch between the following units:

180 °
0.0 %

### Timer (automatic release)

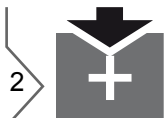
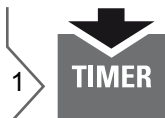

Adjust delay of automatic release (max. 60 sec, standard setting 5 sec)

**i** Once the key is released with the laser activated, the remaining seconds until the measurement are displayed in a countdown. The delayed release is recommended for precise aiming e.g. at long distances. It avoids shaking of the device when pressing the measurement key.

# Operations

## Beep ON/OFF



2 sec  
simultaneously



## Illumination ON/OFF



2 sec  
simultaneously

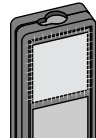

## Measuring Functions

### Measuring single distance

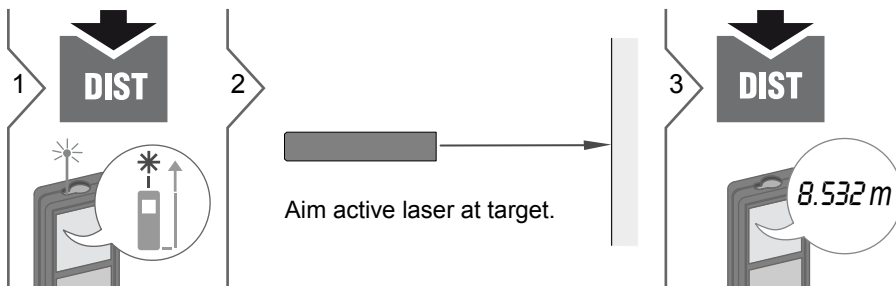

**i** Target surfaces: Measuring errors can occur when measuring to colourless liquids, glass, styrofoam or semi-permeable surfaces or when aiming at high gloss surfaces. Against dark surfaces the measuring time increases.

### Permanent / Minimum-Maximum measuring

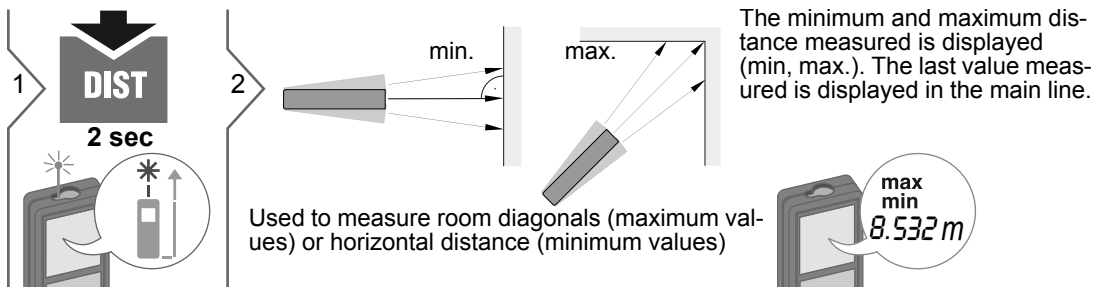

**i** Stops permanent / minimum-maximum measuring.

### Add / Subtract

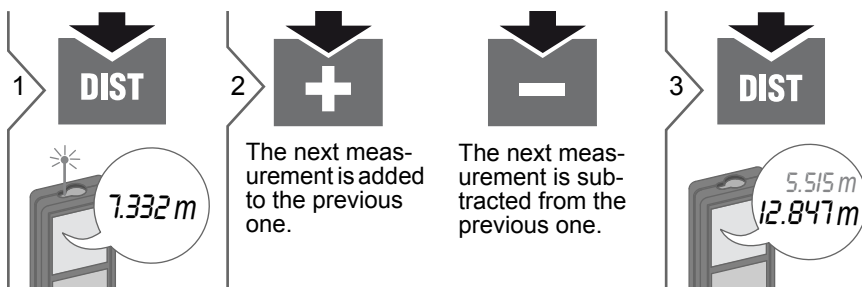

**i** The result is shown in the main line and the measured value above. This process can be repeated as required. The same process can be used for adding or subtracting areas or volumes.

# Measuring Functions

## Area

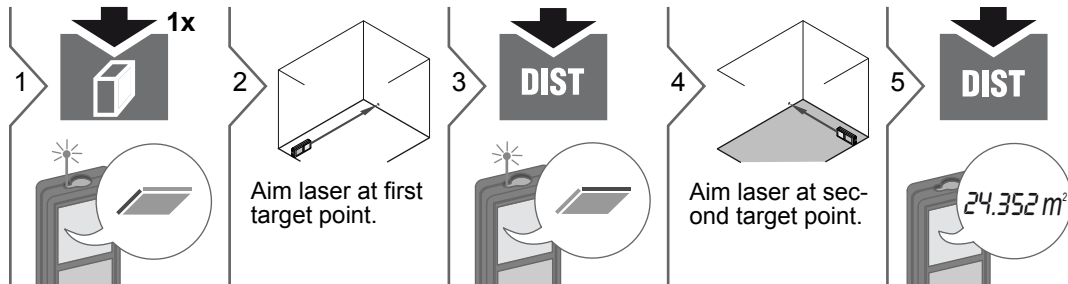

i

The result is shown in the main line and the measured value above.

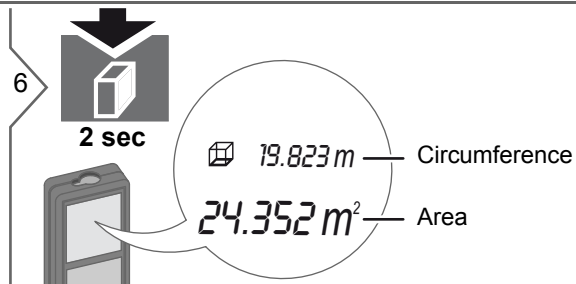



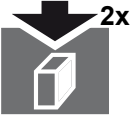
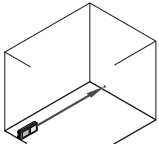

# Measuring Functions

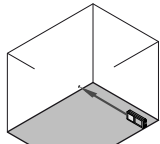
## Volume

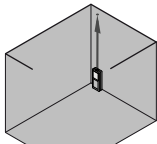
1   2 Aim laser at first target point.

3   4 Aim laser at second target point.

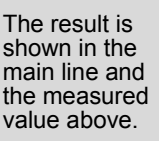
5   6 Aim laser at third target point.

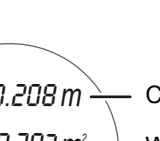
7   8   6

The result is shown in the main line and the measured value above.

$78.694 m^3$

$80.208 m$  — Circumference  
 $208.703 m^2$  — Wall areas  
 $78.694 m^3$  — Volume

# Measuring Functions

## Triangular area

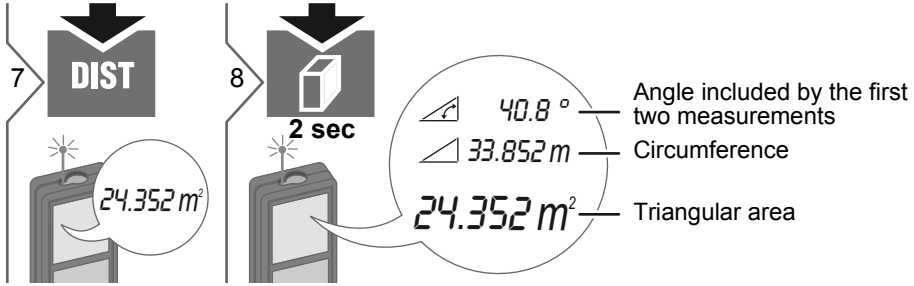
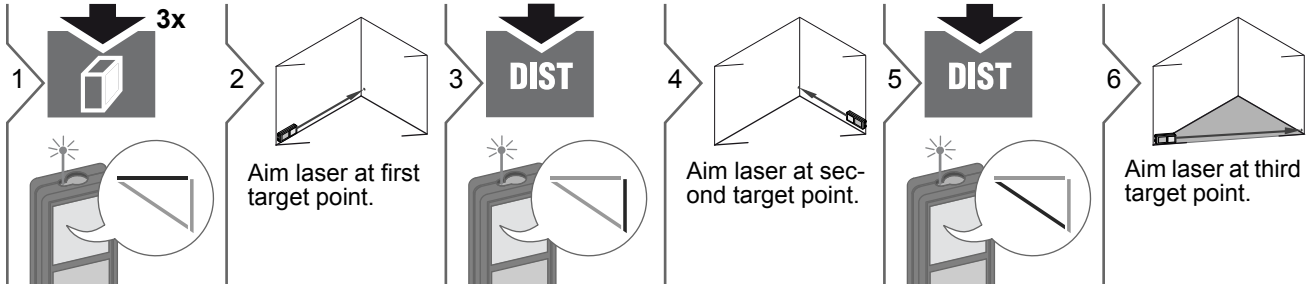

## Measuring Functions

### Pythagoras (2-point)

1  1x

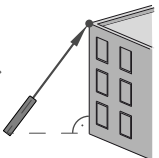
2  Aim laser at upper point.

3  **DIST**

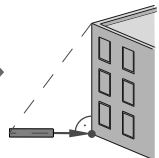
4  Aim laser rectangular at lower point.

5  **DIST**

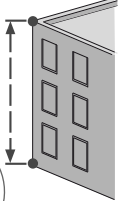
 8.294 m

**i** The result is shown in the main line and the measured distance above. Pressing the measuring key for 2 sec in the function activates automatically Minimum or Maximum measurement.

### Pythagoras (3-point)

1  2x

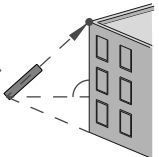
2  Aim laser at upper point.

3  **DIST**

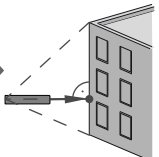
4  Aim laser at rectangular point.

5  **DIST**

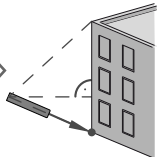
6  Aim laser at lower point.

7  **DIST**

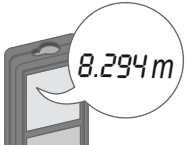
 8.294 m

**i** The result is shown in the main line and the measured distance above. Pressing the measuring key for 2 sec in the function activates automatically Minimum or Maximum measurement.

# Measuring Functions

## Pythagoras (partial height)

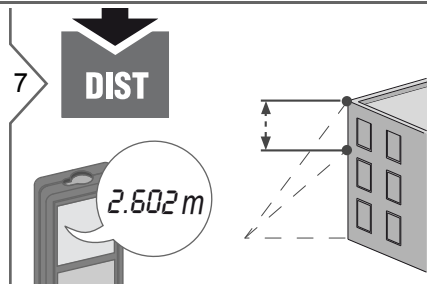
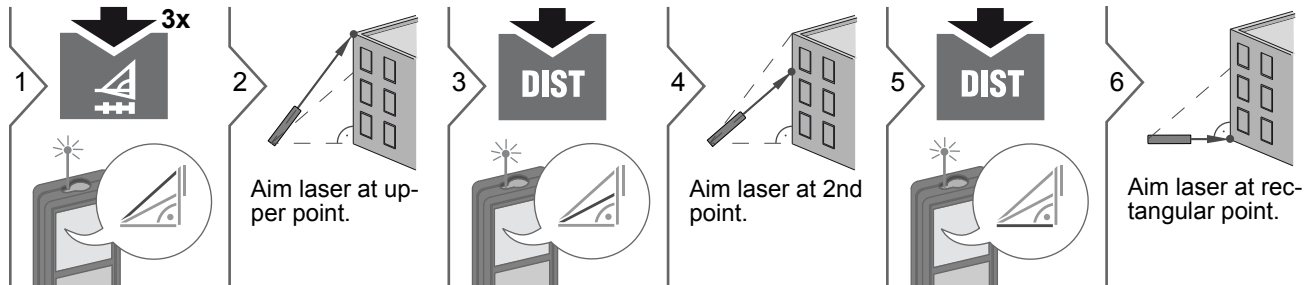

**i** The result is shown in the main line and the measured distance above.  
Pressing the measuring key for 2 sec in the function activates automatically Minimum or Maximum measurement.

# Measuring Functions

## Stake out

**1** **4x**

**2** Adjust value.

**3** **DIST**

Approve value and start measurement.

**4** Move device slowly along the stake-out line. The distance to the next stake out point is displayed.

0.240 m is missing up to next 0.625 m distance.

**i** When approaching a stake out point to less than 0.1 m the instrument starts to beep. The function can be stopped by pressing the CLEAR/OFF button.

## Smart Horizontal Mode

**1** **1x**

**2** Aim laser at target.

**3** **DIST**

$24.3^\circ$  —  $\alpha$   
 $0.032\text{ m}$  —  $y$   
 $4.827\text{ m}$  —  $z$

(up to  $360^\circ$  and a transverse tilt of  $\pm 10^\circ$ )

**i** Press key again to switch off horizontal measurement.

# Measuring Functions

## Height tracking

**i** This function displays continuously the tracking height if the device is turned on a tripod. No 2nd distance measuring is needed as only the angle is automatically measured.

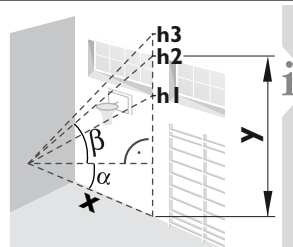
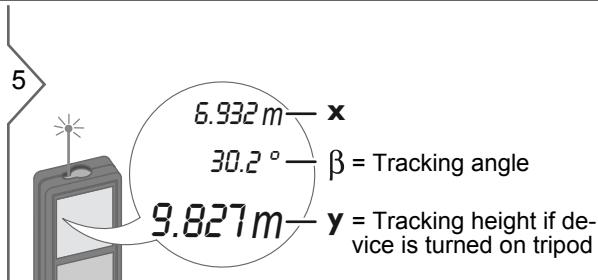
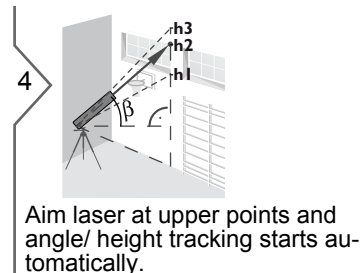
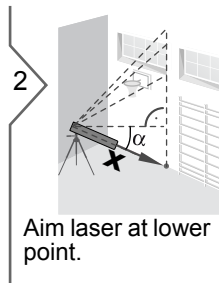
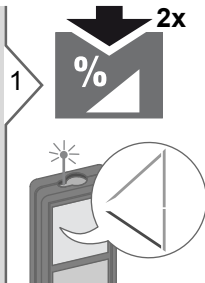

The tracked height "y" is in 90° to the 1st aimed point "x".



## Leveling

**i** This function displays continuously the inclination of the device. From an inclination of  $\pm 5^\circ$  the device starts beeping frequently. The more it gets to  $0^\circ$  the faster it beeps. If an inclination of  $\pm 0.3^\circ$  is reached the device beeps continuously.

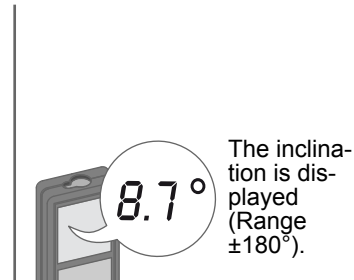
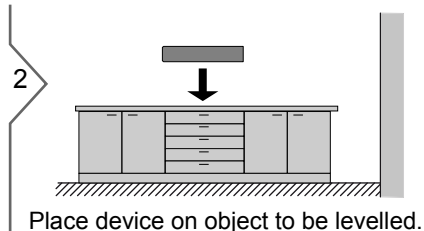
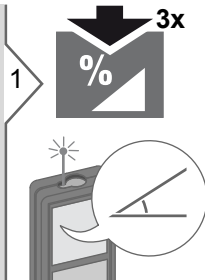

## Measuring Functions

### Memory (20 last displays)

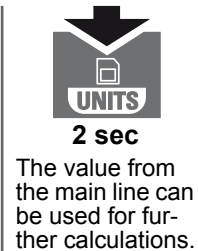
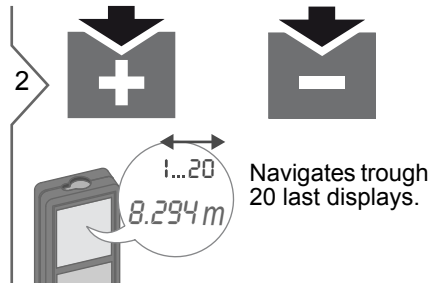
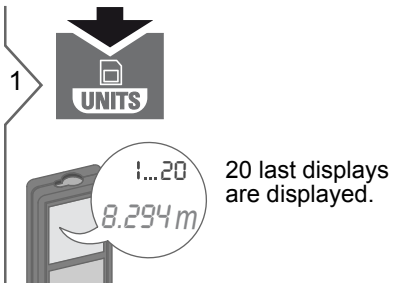

### Delete Memory

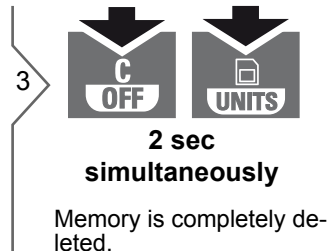



# Calibration

## Calibration of tilt sensor (Tilt Calibration)

**1**  **2 sec simultaneously**

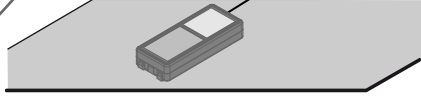
**MEAS 1 HOR**  
**CAL**

**2**  Place device on absolutely flat surface.

**3**  **DIST**

**MEAS 2 turn**  
**180°**

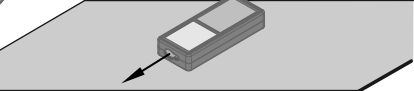
**4**  Turn the device horizontally by 180° and place it again on absolutely flat surface.

**5**  **DIST**

**MEAS 3 VER**  
**CAL**

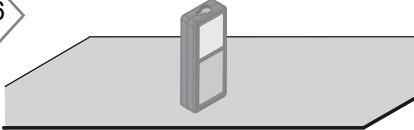
**6**  Turn the device upside down and place it again on absolutely flat surface.

**7**  **DIST**

**MEAS 4 turn**  
**180°**

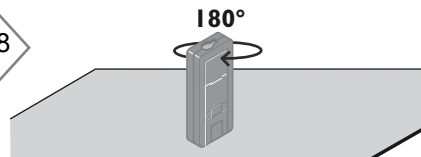
**8**  Turn the device horizontally by 180° and place it again on absolutely flat surface.

**9**  **DIST**

**OK**  
**CAL**

**i** After 2 sec the device goes back to the normal mode.

Distance measurement	
<b>Typical Measuring Tolerance*</b>	± 1.0 mm / 0.04 in ***
<b>Maximum Measuring Tolerance**</b>	± 2.0 mm / 0.08 in ***
<b>Range of target plate</b>	100 m / 330 ft
<b>Typical Range*</b>	80 m / 262 ft
<b>Range at unfavourable condition ****</b>	60 m / 197 ft
<b>Smallest unit displayed</b>	0.1 mm / 1/32 in
<b>Ø laser point at distances</b>	6 /30 / 60 mm (10 / 50 / 100 m)
Tilt measurement	
<b>Measuring tolerance to laser beam*****</b>	± 0.2°
<b>Measuring tolerance to housing*****</b>	± 0.2°
<b>Range</b>	360°
General	
<b>Laser class</b>	2
<b>Laser type</b>	635 nm, < 1 mW
<b>Beam divergence</b>	0.16 x 0.6 mrad
<b>Impulse duration</b>	0.2 x 10 <sup>-9</sup> s - 0.8 x 10 <sup>-9</sup> s
<b>Protection class</b>	IP54 (dust- and splash water protected)
<b>Autom. laser switch off</b>	after 90 s
<b>Autom. power switch-off</b>	after 180 s
<b>Battery durability (2 x AAA)</b>	up to 5000 measurements
<b>Dimension (H x D x W)</b>	125.2 x 58 x 32.6 mm 4.9 x 2.3 x 1.3 in
<b>Weight (with batteries)</b>	154 g / 5.43 oz
<b>Temperature range:</b>	
- Storage	-25 to 70 °C -13 to 158 °F
- Operation	-10 to 50 °C 14 to 122 °F

\* applies for 100 % target reflectivity (white painted wall), low background illumination, 25 °C

\*\* applies for 10 to 500 % target reflectivity, high background illumination, - 10 °C to + 50 °C

\*\*\* Tolerances apply from 0.05 m to 10 m with a confidence level of 95%. The maximum tolerance may deteriorate to 0.1 mm/m between 10 m to 30 m and to 0.2 mm/m for distances above 30 m

\*\*\*\* applies for 100 % target reflectivity, background illumination of approximately 30'000 lux

\*\*\*\*\* after user calibration. Additional angle related deviation of +/- 0.01° per degree up to +/-45° in each quadrant. Applies at room temperature. For the whole operating temperature range the maximum deviation increases by +/- 0.1°.

i For accurate indirect results, the use of a tripod is recommended. For accurate tilt measurements a transverse tilt should be avoided.

Functions	
<b>Distance measuring</b>	yes
<b>Min/Max measuring</b>	yes
<b>Permanent measuring</b>	yes
<b>Stake-out</b>	yes
<b>Addition/Subtraction</b>	yes
<b>Area</b>	yes
<b>Volume</b>	yes
<b>Pythagoras</b>	2-point, 3-point, partial height
<b>Smart Horizontal Mode / Indirect height</b>	yes
<b>Height tracking</b>	yes
<b>Levelling</b>	yes
<b>Memory</b>	20 displays
<b>Beep</b>	yes
<b>Illuminated display</b>	yes
<b>Multifunctional endpiece</b>	yes

## Message Codes

If the message **Error** does not disappear after switching on the device repeatedly, contact the dealer.

If the message **InFo** appears with a number, press the Clear button and observe the following instructions:

No.	Cause	Correction
156	Transverse tilt greater than 10°	Hold the instrument without any transverse tilt.
162	Calibration mistake	Make sure, the device is placed on a absolutely horizontal and flat surface. Repeat the calibration procedure. If the mistake still occurs, contact your dealer.
204	Calculation error	Perform measurement again.
252	Temperature too high	Let device cool down.
253	Temperature too low	Warm device up.
255	Received signal too weak, measuring time too long	Change target surface (e.g. white paper).
256	Received signal too high	Change target surface (e.g. white paper).
257	Too much background light	Shadow target area.
258	Measurement outside of measuring range	Correct range.
260	Laser beam interrupted	Repeat measurement.

## Care

- Clean the device with a damp, soft cloth.
- Never immerse the device in water.
- Never use aggressive cleaning agents or solvents.

## Warranty

### Europe:

- 30 day no risk satisfaction guarantee
  - One year free service
  - One year full warranty
- Detailed information are available on the internet at [www.2helpU.com](http://www.2helpU.com).

### North America:

- Three year limited warranty
  - One year free service
  - 90 day money back guarantee
- Detailed information are available on the internet at [www.dewalt.com](http://www.dewalt.com).

## Safety Instructions

The person responsible for the instrument must ensure that all users understand these directions and adhere to them.

### Areas of responsibility

#### Responsibilities of the manufacturer of the original equipment:

Europe:

DEWALT

D-65510 Idstein, Germany

[www.2helpU.com](http://www.2helpU.com)

[www.dewalt.eu](http://www.dewalt.eu)

North America:

DEWALT Industrial Tool Co.

Baltimore, MD21286, USA

For service call 1-800-4-DEWALT.

[www.dewalt.com](http://www.dewalt.com)

The company above is responsible for supplying the product, including the User Manual in a completely safe condition. The company above is not responsible for third party accessories.

#### Responsibilities of the person in charge of the instrument:

- To understand the safety instructions on the product and the instructions in the User Manual.
- To be familiar with local safety regulations relating to accident prevention.
- Always prevent access to the product by unauthorised personnel.

## Safety Instructions

### Permitted use

- Measuring distances
- Tilt measurement

### Prohibited use

- Using the product without instruction
- Using outside the stated limits
- Deactivation of safety systems and removal of explanatory and hazard labels
- Opening of the equipment by using tools (screwdrivers, etc.)
- Carrying out modification or conversion of the product
- Use of accessories from other manufacturers without express approval
- Deliberate dazzling of third parties; also in the dark
- Inadequate safeguards at the surveying site (e.g. when measuring on roads, construction sites, etc.)
- Deliberate or irresponsible behaviour on scaffolding, when using ladders, when measuring near machines which are running or near parts of machines or installations which are unprotected
- Aiming directly in the sun

### Hazards in use

#### **WARNING**

Watch out for erroneous measurements if the instrument is defective or if it has been dropped or has been misused or modified. Carry out periodic test measurements. Particularly after the instrument has been subject to abnormal use, and before, during and after important measurements.

#### **CAUTION**

Never attempt to repair the product yourself. In case of damage, contact a local dealer.

#### **WARNING**

Changes or modifications not expressly approved could void the user's authority to operate the equipment.

### Limits of use

- Refer to section "Technical data".
- The device is designed for use in areas permanently habitable by humans. Do not use the product in explosion hazardous areas or in aggressive environments.

### Disposal

#### **CAUTION**

Flat batteries must not be disposed of with household waste. Care for the environment and take them to the collection points provided in accordance with national or local regulations.

The product must not be disposed with household waste.

Dispose of the product appropriately in accordance with the national regulations in force in your country.



Adhere to the national and country specific regulations.

Product specific treatment and waste management can be downloaded from our homepage.

### Electromagnetic Compatibility (EMC)

#### **WARNING**

The device conforms to the most stringent requirements of the relevant standards and regulations.

Yet, the possibility of causing interference in other devices cannot be totally excluded.

## Safety Instructions

### FCC statement (applicable in U.S.)

This equipment has been tested and found to comply with the limits for a Class B digital device, pursuant to part 15 of the FCC Rules. These limits are designed to provide reasonable protection against harmful interference in a residential installation. This equipment generates, uses and can radiate radio frequency energy and, if not installed and used in accordance with the instructions, may cause harmful interference to radio communications.

However, there is no guarantee that interference will not occur in a particular installation. If this equipment does cause harmful interference to radio or television reception, which can be determined by turning the equipment off and on, the user is encouraged to try to correct the interference by one or more of the following measures:

- Reorient or relocate the receiving antenna.
- Increase the separation between the equipment and receiver.
- Connect the equipment into an outlet on a circuit different from that to which the receiver is connected.
- Consult the dealer or an experienced radio/TV technician for help.

### Laser classification

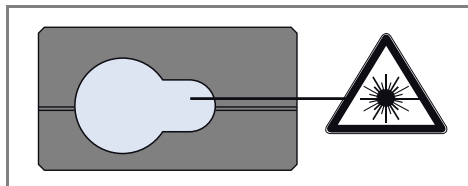

The device produces visible laser beams, which are emitted from the instrument:  
It is a Class 2 laser product in accordance with:

- IEC60825-1 : 2007 „Radiation safety of laser products“

### Laser Class 2 products:

Do not stare into the laser beam or direct it towards other people unnecessarily. Eye protection is normally afforded by aversion responses including the blink reflex.

### WARNING

Looking directly into the beam with optical aids (e.g. binoculars, telescopes) can be hazardous.

### CAUTION

Looking into the laser beam may be hazardous to the eyes.

### Labelling

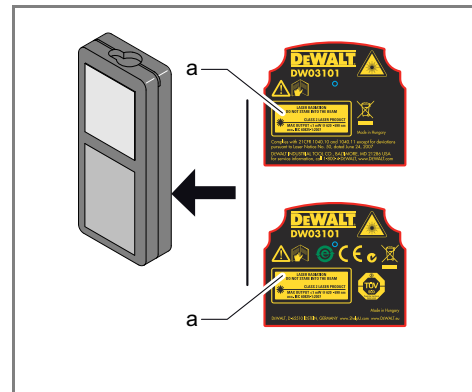

Attach the laser sticker (a) of your country language.

# Inhalt

<b>Inbetriebnahme</b> .....	<b>2</b>	Speicher löschen .....	15
Einleitung .....	2	<b>Kalibrierung</b> .....	<b>16</b>
Übersicht .....	2	Kalibrierung des Neigungssensors (Neigungskalibrierung) .....	16
Anzeige .....	3	<b>Technische Daten</b> .....	<b>17</b>
Batterien einsetzen .....	3	<b>Meldungscodes</b> .....	<b>18</b>
<b>Bedienung</b> .....	<b>4</b>	<b>Pflege</b> .....	<b>18</b>
Ein- / Ausschalten .....	4	<b>Garantie</b> .....	<b>18</b>
Zurück .....	4	<b>Sicherheitshinweise</b> .....	<b>18</b>
Meldungscodes .....	4	Verantwortungsbereiche .....	18
Einstellung der Messebene / Stativ .....	4	Bestimmungsgemäße Verwendung .....	19
Multifunktionales Endstück .....	5	Sachwidrige Verwendung .....	19
Einstellung der Einheit der Distanz .....	5	Gebrauchsgefahren .....	19
Einstellung der Einheit der Neigung .....	5	Einsatzgrenzen .....	19
Timer (automatischer Auslöser) .....	5	Entsorgung .....	19
Beep (Ein / Aus) .....	6	Elektromagnetische Verträglichkeit (EMV) .....	19
Beleuchtung (Ein / Aus) .....	6	Laserklassifizierung .....	20
<b>Messfunktionen</b> .....	<b>7</b>	Beschilderung .....	20
Messung von Einzeldistanzen .....	7		
Dauermessung / Minimum-/Maximum-Messung .....	7		
Addieren / Subtrahieren .....	7		
Fläche .....	8		
Volumen .....	9		
Dreiecksfläche .....	10		
Pythagoras (2 Punkte) .....	11		
Pythagoras (3 Punkte) .....	11		
Pythagoras (Teilhöhe) .....	12		
Absteckung .....	13		
Smart Horizontal Mode .....	13		
Höhentracking .....	14		
Neigung .....	14		
Speicher (letzte 20 Anzeigen) .....	15		

# Inbetriebnahme

## Einleitung

 Sicherheitshinweise und Gebrauchsanweisung vor der Erstinbetriebnahme des Geräts sorgfältig lesen.

 Der Betreiber stellt sicher, dass alle Benutzer diese Hinweise verstehen und befolgen.

Die verwendeten Symbole haben folgende Bedeutung:

### **WARNUNG**

Gebrauchsgefahr oder sachwidrige Verwendung, die zu schweren Personenschäden oder zum Tod führen kann.

### **VORSICHT**

Gebrauchsgefahr oder sachwidrige Verwendung, die zu geringen Personenschäden, aber erheblichen Sach-, Vermögens- oder Umweltschäden führen kann.

 Nutzungsinformationen, die dem Benutzer helfen, das Produkt technisch richtig und effizient einzusetzen.

## Übersicht

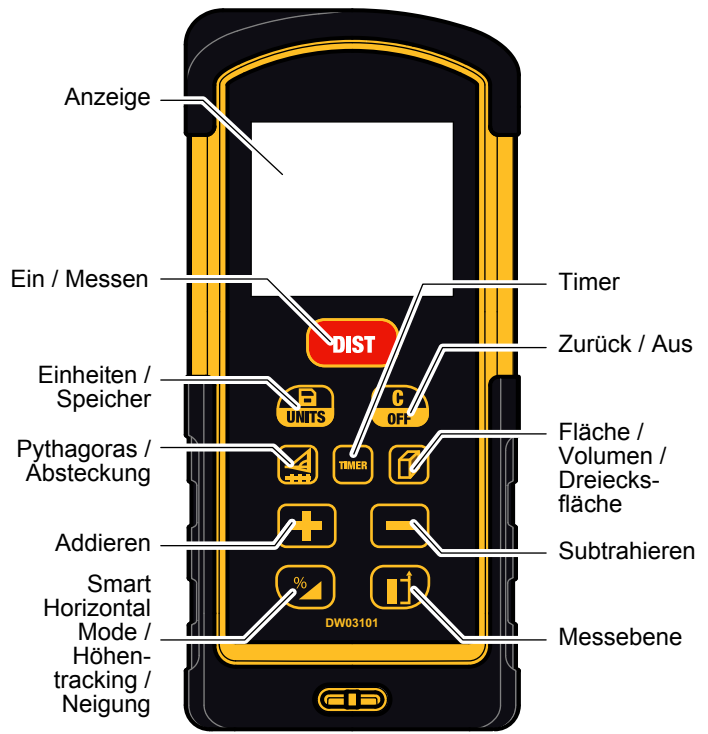

## Anzeige

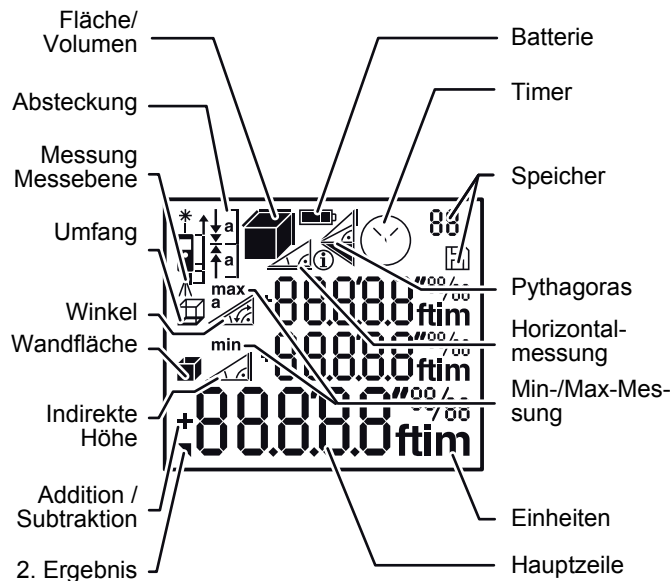

## Batterien einsetzen

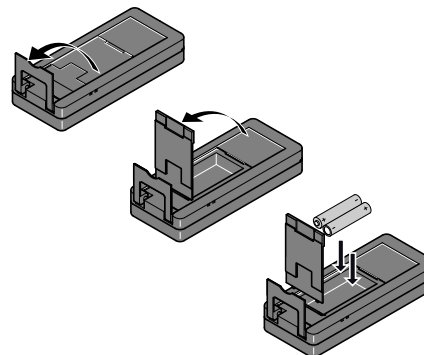

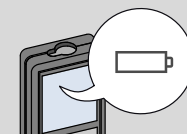

i

Um den zuverlässigen Betrieb zu gewährleisten, keine Zink-Kohle-Batterien verwenden. Batterien wechseln, wenn das Batteriesymbol blinkt.



# Bedienung

## Ein- / Ausschalten

**2 sec**

Gerät wird ausgeschaltet.



Taste ON 2 sec drücken, um den kontinuierlichen Lasermodus zu aktivieren. Wird 180 sec lang keine Taste gedrückt, schaltet sich das Gerät automatisch aus.

## Zurück



**1x**

Letzten Vorgang rückgängig machen.



**2x**

Aktuelle Funktion verlassen und in den Standardbetriebsmodus zurückkehren.

## Meldungscodes

Wird das Infosymbol in Kombination mit einer Zahl angezeigt, Hinweise im Abschnitt "Meldungscodes" beachten. Beispiel:



## Einstellung der Messebene / Stativ

1

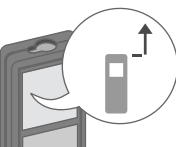
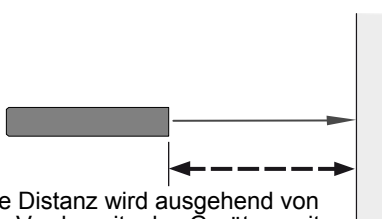
Die Distanz wird ausgehend von der Vorderseite des Geräts ermittelt.

2

Die Distanz wird dauerhaft ausgehend vom Stativgewinde ermittelt.

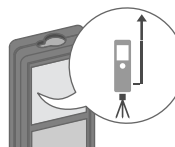
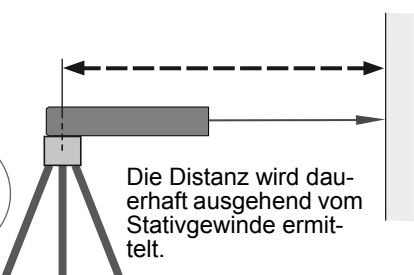
3

Die Distanz wird ausgehend von der Rückseite des Geräts ermittelt (Standardeinstellung).

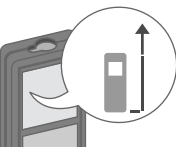
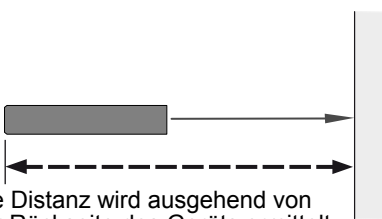
# Bedienung

## Multifunktionales Endstück

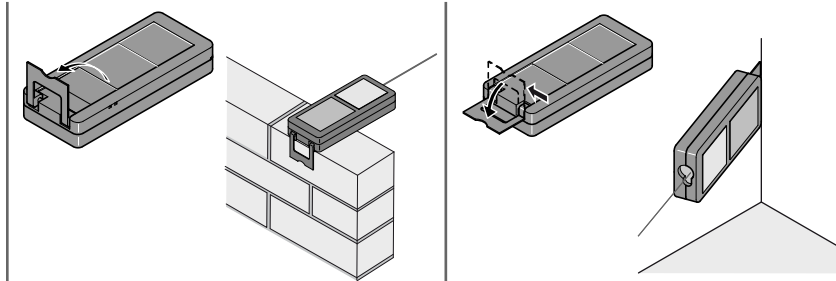

i

Die Ausrichtung des Endstücks wird automatisch erkannt und der Nullpunkt entsprechend angepasst.

## Einstellung der Einheit der Distanz



2 sec

Wechsel zwischen den folgenden Einheiten:

0.000 m	0.00 ft
0.0000 m	0'00" 1/32
0.00 m	0.00 in
	0 in 1/32

## Einstellung der Einheit der Neigung



2 sec gleichzeitig

Wechsel zwischen den folgenden Einheiten:

180 °
0.0 %

## Timer (automatischer Auslöser)

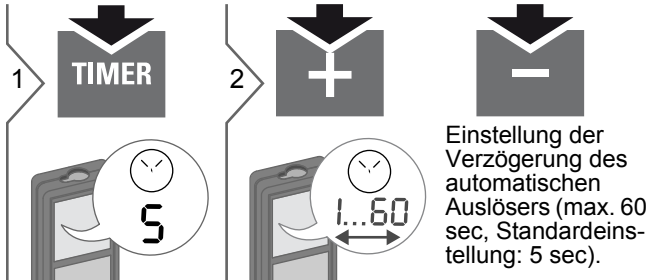

i

Sobald die Taste bei aktiviertem Laser losgelassen wird, werden die bis zur Messung verbleibenden Sekunden als Countdown angezeigt. Die verzögerte Auslösung wird z.B. für präzises Anzielen auf grosse Entfernungen empfohlen. So kann ein Wackeln des Geräts beim Drücken der Messtaste vermieden werden.

# Bedienung

## Beep (Ein / Aus)



2 sec  
gleichzeitig



## Beleuchtung (Ein / Aus)



2 sec  
gleichzeitig

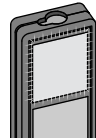

## Messfunktionen

### Messung von Einzeldistanzen

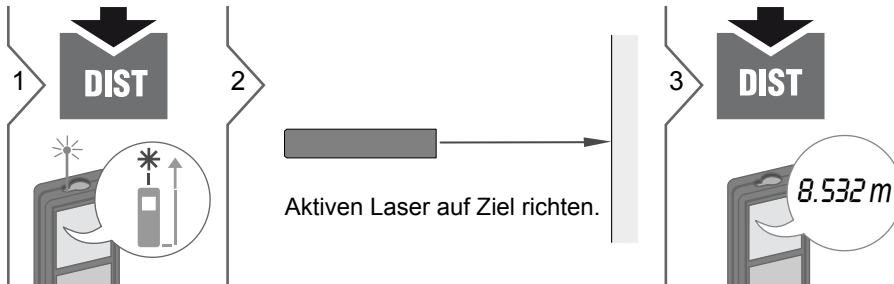

i

Zieloberflächen: Messfehler können bei der Messung auf farblose Flüssigkeiten, Glas, Styropor oder halbdurchlässige bzw. hochglänzende Oberflächen auftreten. Bei der Messung auf dunkle Oberflächen erhöht sich die Messzeit.

### Dauermessung / Minimum-/Maximum-Messung

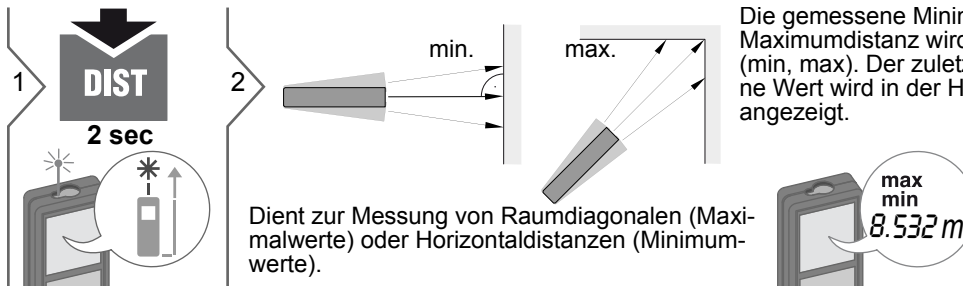

Die gemessene Minimum- und Maximumdistanz wird angezeigt (min, max). Der zuletzt gemessene Wert wird in der Hauptzeile angezeigt.

3



Beendet die Dauermessung / Minimum-/Maximum-Messung.

### Addieren / Subtrahieren

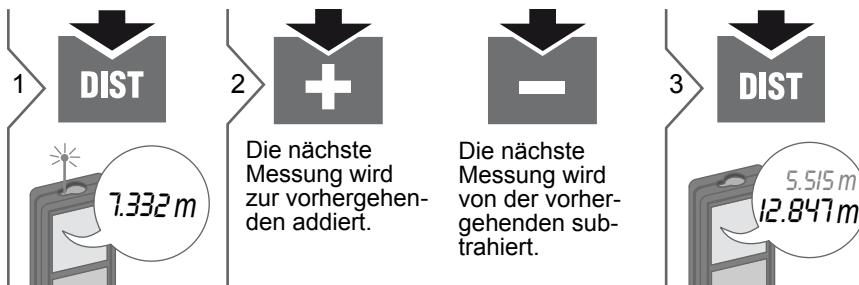

i

Das Ergebnis wird in der Hauptzeile, der Messwert darüber angezeigt. Dieses Vorgehen bei Bedarf wiederholen. Anhand dieser Vorgangsweise können auch Flächen oder Volumen addiert und subtrahiert werden.

Fläche

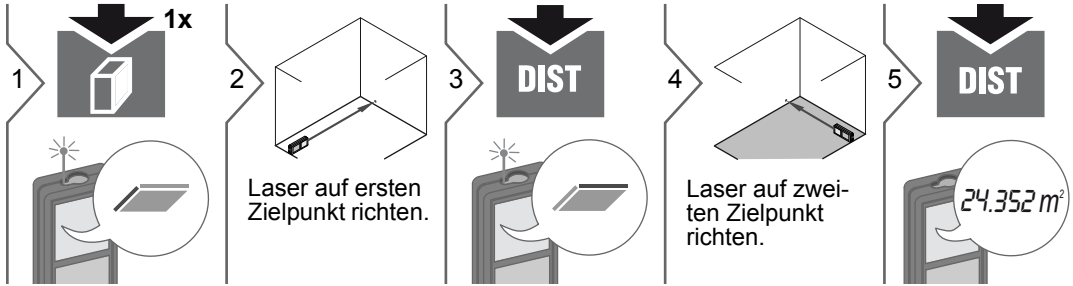

**i** Das Ergebnis wird in der Hauptzeile, der Messwert darüber angezeigt.

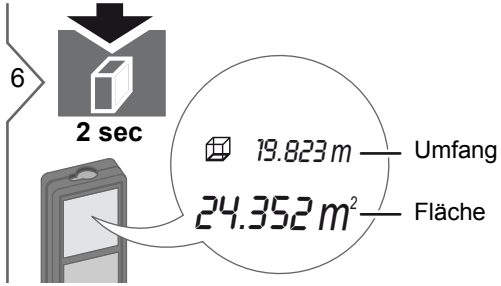

# Messfunktionen

## Volumen

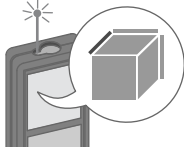
1  

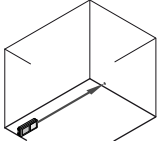
2  **Laser auf ersten Zielpunkt richten.**

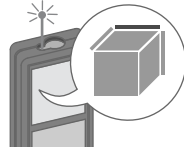

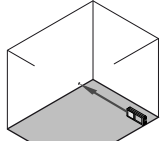
3  

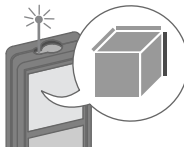
4  **Laser auf zweiten Zielpunkt richten.**

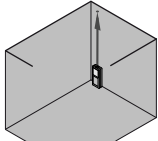
5  

6  **Laser auf dritten Zielpunkt richten.**

---

7   **78.694 m<sup>3</sup>**

**i** Das Ergebnis wird in der Hauptzeile, der Messwert darüber angezeigt.

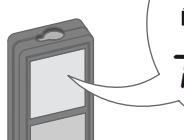
8   **80.208 m** — Umfang  
**208.703 m<sup>2</sup>** — Wandflächen  
**78.694 m<sup>3</sup>** — Volumen

## Dreiecksfläche

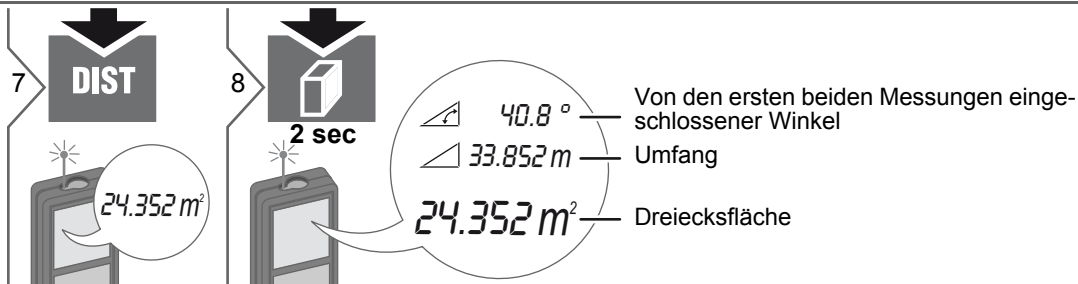
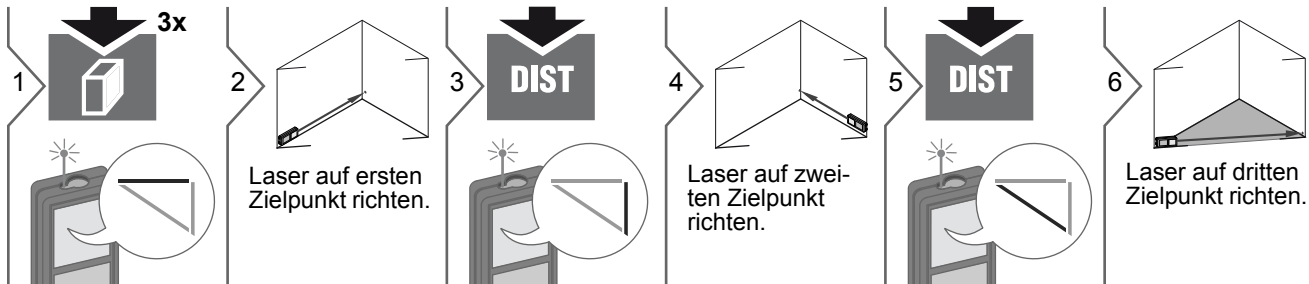

## Messfunktionen

### Pythagoras (2 Punkte)

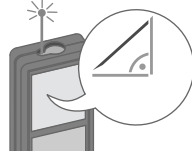
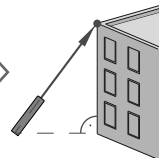
1    **Laser auf oberen Punkt richten.**

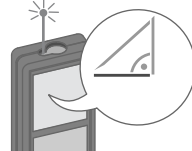
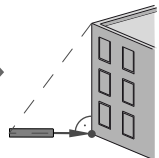
2    **Laser rechtwinklig auf unteren Punkt richten.**

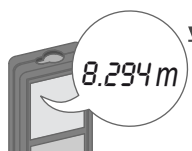
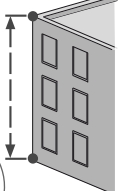

3    **Das Ergebnis wird in der Hauptzeile, die gemessene Distanz darüber angezeigt. Drücken der Messtaste für 2 sec in dieser Funktion aktiviert automatisch die Minimum-/Maximum-Messung.**

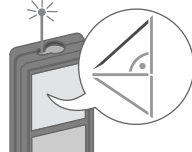
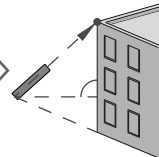
### Pythagoras (3 Punkte)

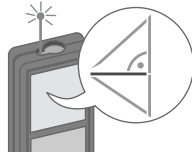
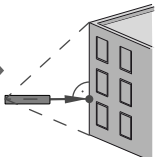
1    **Laser auf oberen Punkt richten.**

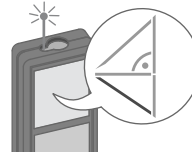
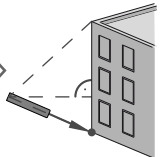
2    **Laser rechtwinklig auf den Messpunkt richten.**

3    **Laser auf unteren Punkt richten.**

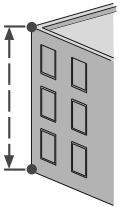
7    **Das Ergebnis wird in der Hauptzeile, die gemessene Distanz darüber angezeigt. Drücken der Messtaste für 2 sec in dieser Funktion aktiviert automatisch die Minimum-/Maximum-Messung.**

## Pythagoras (Teilhöhe)

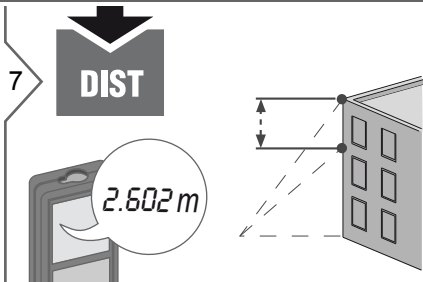
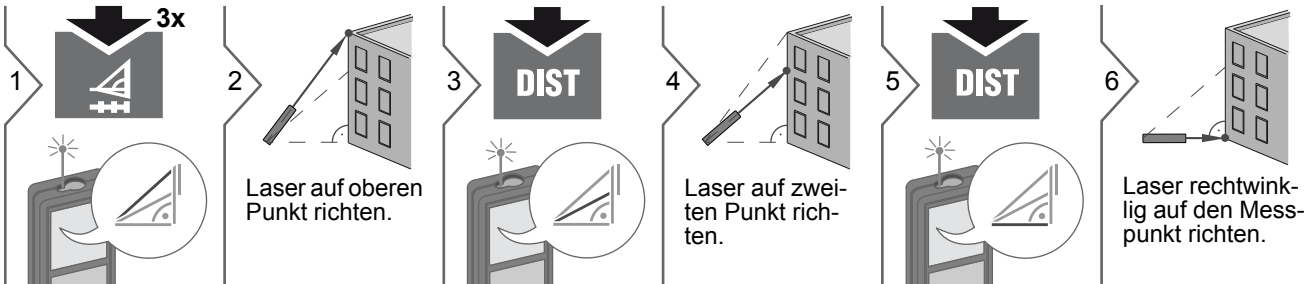

**i** Das Ergebnis wird in der Hauptzeile, die gemessene Distanz darüber angezeigt. Drücken der Messtaste für 2 sec in dieser Funktion aktiviert automatisch die Minimum-/Maximum-Messung.

## Absteckung

1 **4x**  
1.000 m

2 Wert einstellen.  
0.625 m

3 Wert bestätigen und Messung starten.

4

Gerät langsam entlang der Abstecklinie bewegen. Die Distanz zum nächsten Absteckpunkt wird angezeigt.

0.240 m Abstand bis zur nächsten 0.625 m Distanz.

**i** Bei einer Entfernung von weniger als 0.1 m zum nächsten Absteckpunkt beginnt das Gerät zu piepen. Diese Funktion kann durch Drücken der Taste CLEAR/OFF beendet werden.

## Smart Horizontal Mode

1 **1x**

2 Laser auf Ziel richten.

3 **DIST**  
4.827 m

24.3° —  $\alpha$   
0.032 m —  $y$   
4.827 m —  $z$

**i** Taste erneut drücken, um Horizontalmessung zu deaktivieren.

(Bis zu 360° und Querneigung von  $\pm 10^\circ$ )

## Höhentracking

**i** Diese Funktion zeigt laufend die ermittelte Höhe an, wenn das Gerät auf einem Stativ gedreht wird. Es wird keine zweite Distanzmessung benötigt, da nur der Winkel automatisch gemessen wird.

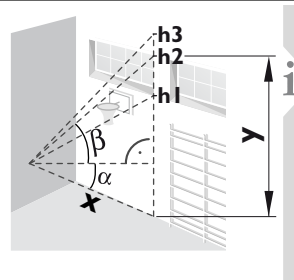
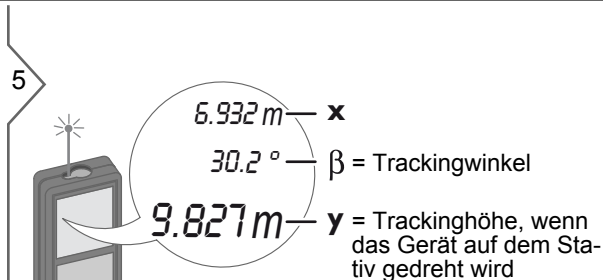
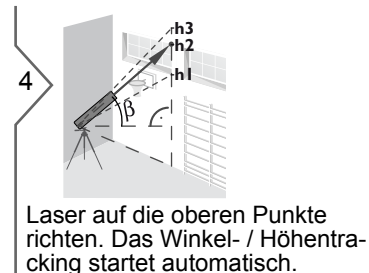
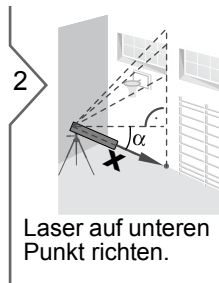
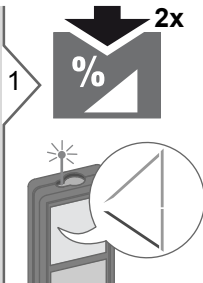

Die getrackte Höhe "y" liegt in einem Winkel von 90° zum ersten angezielten Punkt "x".



## Neigung

**i** Diese Funktion zeigt die Neigung des Geräts laufend an. Ab einer Neigung von  $\pm 5^\circ$  gibt das Gerät Signaltöne ab. Je mehr sich die Neigung des Geräts an  $0^\circ$  annähert, desto raschere Signaltöne werden abgegeben. Wenn eine Neigung von  $\pm 0.3^\circ$  erreicht ist, gibt das Gerät einen Dauerton ab.

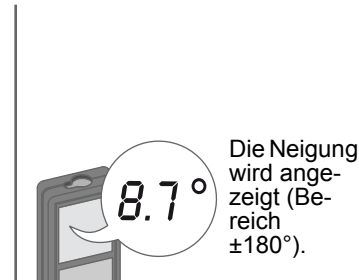
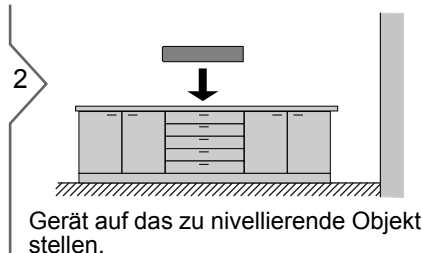
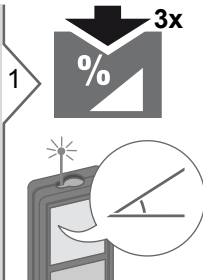

## Messfunktionen

### Speicher (letzte 20 Anzeigen)

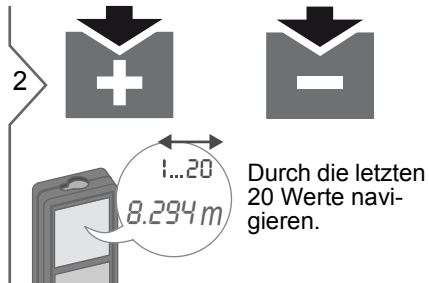
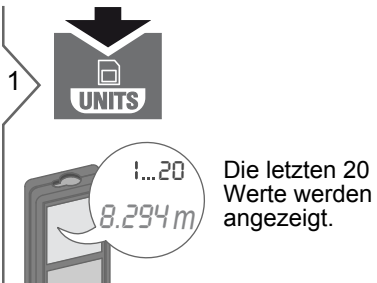

### Speicher löschen

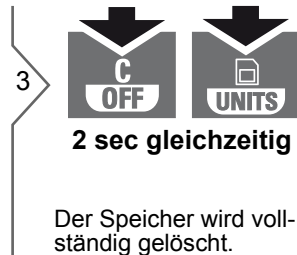



# Kalibrierung

## Kalibrierung des Neigungssensors (Neigungskalibrierung)

1  2 sec gleichzeitig

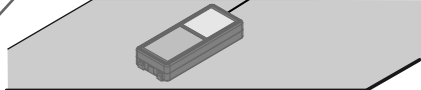
**MEAS 1 HOR**  
**CAL**

2  Gerät auf absolut ebene Oberfläche stellen.

3  **DIST**

**MEAS 2 turn**  
**180°**

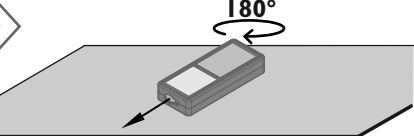
4  Gerät horizontal um 180° drehen und erneut auf absolut ebene Oberfläche stellen.

5  **DIST**

**MEAS 3 VER**  
**CAL**

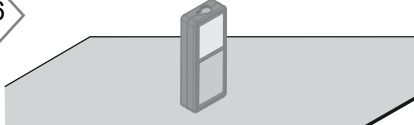
6  Gerät auf den Kopf stellen und erneut auf absolut ebene Oberfläche stellen.

7  **DIST**

**MEAS 4 turn**  
**180°**

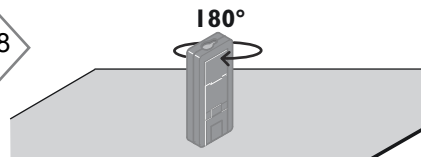
8  Gerät horizontal um 180° drehen und erneut auf absolut ebene Oberfläche stellen.

9  **DIST**

**OK**  
**CAL**

**i** Nach 2 sec wechselt das Gerät zurück in den normalen Modus.

Distanzmessung	
Typische Messtoleranz *	± 1.0 mm / 0.04 in***
Maximale Messtoleranz **	± 2.0 mm / 0.08 in***
Reichweite mit Zieltafel	100 m / 330 ft
Typische Reichweite *	80 m / 262 ft
Reichweite bei ungünstigen Bedingungen ****	60 m / 197 ft
Kleinste Anzeigeeinheit	0.1 mm / 1/32 in
Ø Laserpunkt auf Entfernung	6 / 30 / 60 mm (10 / 50 / 100 m)
Neigungsmessung	
Messtoleranz zu Laserstrahl*****	± 0.2°
Messtoleranz zu Gehäuse*****	± 0.2°
Reichweite	360°
Allgemeines	
Laserklasse	2
Lasertyp	635 nm, < 1 mW
Strahldivergenz	0.16 x 0.6 mrad
Impulsdauer	0.2 x 10 <sup>-9</sup> s - 0.8 x 10 <sup>-9</sup> s
Schutzklasse	IP54 (staub- und spritzwassergeschützt)
Autom. Abschaltung des Lasers	nach 90 s
Autom. Abschaltung des Geräts	nach 180 s
Batterielebensdauer (2 x AAA)	bis zu 5000 Messungen
Abmessungen (H x T x B)	125.2 x 58 x 32.6 mm 4.9 x 2.3 x 1.3 in
Gewicht (mit Batterien)	154 g / 5.43 oz
Temperaturbereich:	
- Lagerung	-25 bis 70 °C -13 bis 158 °F
- Betrieb	-10 bis 50 °C 14 bis 122 °F

\* gilt für 100 % Reflexionsvermögen des Ziels (weiss gestrichene Wand), schwache Hintergrundbeleuchtung, 25 °C

\*\* gilt für 10 bis 500 % Reflexionsvermögen des Ziels, starke Hintergrundbeleuchtung, - 10 °C bis + 50 °C

\*\*\* Toleranzen gelten von 0.05 m bis 10 m mit einem Konfidenzniveau von 95 %. Bei Distanzen zwischen 10 m und 30 m kann sich die maximale Toleranz auf 0.1 mm/m verschlechtern, ab einer Distanz von 30 m auf 0.2 mm/m

\*\*\*\* gilt für 100 % Reflexionsvermögen des Ziels, Hintergrundbeleuchtung ca. 30'000 Lux

\*\*\*\*\* nach der Kalibrierung durch den Anwender. Weitere winkelbezogene Abweichung von +/- 0.01° pro Grad bis zu +/-45° in jedem Quadranten. Gilt bei Raumtemperatur. Für den gesamten Betriebstemperaturbereich erhöht sich die Maximalabweichung um +/- 0.1°

i Für präzise indirekte Ergebnisse wird die Verwendung eines Stativs empfohlen. Für genaue Neigungsmessungen sollte eine Querneigung vermieden werden.

Funktionen	
Distanzmessung	ja
Min-/Max-Messung	ja
Dauermessung	ja
Absteckung	ja
Addition/Subtraktion	ja
Fläche	ja
Volumen	ja
Pythagoras	2 Punkte, 3 Punkte, Teilhöhe
Smart Horizontal Mode / indirekte Höhe	ja
Höhentracking	ja
Nivellierung	ja
Speicher	20 Anzeigen
Beep	ja
Beleuchtetes Display	ja
Multifunktionales Endstück	ja

## Meldungscodes

Verschwindet die Meldung **Fehler** nach mehrmaligem Ein- und Ausschalten des Geräts nicht, wenden Sie sich bitte an den Händler.

Wird die Meldung **InFo** in Kombination mit einer Zahl angezeigt, Taste CLEAR drücken und folgende Hinweise beachten:

Nr.	Ursache	Behebung
156	Querneigung grösser 10°	Gerät ohne Querneigung halten.
162	Kalibrierfehler	Sicherstellen, dass das Gerät auf eine absolut horizontale und ebene Oberfläche gestellt wird. Kalibriervorgang wiederholen. Tritt der Fehler wieder auf, wenden Sie sich bitte an Ihren Händler.
204	Fehler in der Berechnung	Messung wiederholen.
252	Temperatur zu hoch	Gerät abkühlen lassen.
253	Temperatur zu niedrig	Gerät wärmen.
255	Empfangssignal zu schwach, Messzeit zu lang	Andere Zieloberfläche verwenden (z.B. weisses Papier).
256	Empfangssignal zu stark	Andere Zieloberfläche verwenden (z.B. weisses Papier).
257	Zu viel Hintergrundlicht	Zielbereich abdunkeln.
258	Messung ausserhalb des Messbereichs	Messbereich korrigieren.
260	Laser wurde unterbrochen	Messung wiederholen.

## Pflege

- Gerät mit einem feuchten, weichen Tuch reinigen.
- Gerät niemals in Wasser eintauchen.
- Gerät niemals mit aggressiven Reinigungs- oder Lösungsmitteln reinigen.

## Garantie

### Europa:

- 30 Tage risikolose Zufriedenheitsgarantie
- Ein Jahr kostenloser Service
- Ein Jahr volle Garantie

Ausführliche Informationen sind im Internet unter [www.2helpU.com](http://www.2helpU.com) verfügbar.

### Nordamerika:

- Drei Jahre beschränkte Garantie
- Ein Jahr kostenloser Service
- 90 Tage Geld-zurück-Garantie

Ausführliche Informationen sind im Internet unter [www.dewalt.com](http://www.dewalt.com) verfügbar.

## Sicherheitshinweise

Der Betreiber stellt sicher, dass alle Benutzer diese Hinweise verstehen und befolgen.

### Verantwortungsbereiche

#### Verantwortungsbereich des Herstellers der Originalausrüstung:

Europa:  
DEWALT  
D-65510 Idstein, Germany  
[www.2helpU.com](http://www.2helpU.com)  
[www.dewalt.eu](http://www.dewalt.eu)

Nordamerika:  
DEWALT Industrial Tool Co.  
Baltimore, MD21286, USA  
Service-Telefonnummer: 1-800-4-DEWALT  
[www.dewalt.com](http://www.dewalt.com)

Das oben genannte Unternehmen ist verantwortlich für die sicherheitstechnisch einwandfreie Lieferung des Produkts inklusive Gebrauchsanweisung. Das oben genannte Unternehmen ist nicht verantwortlich für Fremdzubehör.

#### Verantwortungsbereich des Betreibers:

- Verständnis der Sicherheitshinweise auf dem Produkt und der Instruktionen in der Gebrauchsanweisung.
- Kenntnis der ortsüblichen Sicherheitsvorschriften zur Unfallverhütung.
- Gerät zu jeder Zeit vor dem Zugriff unberechtigter Personen schützen.

## Sicherheitshinweise

### Bestimmungsgemässe Verwendung

- Messung von Distanzen
- Neigungsmessung

### Sachwidrige Verwendung

- Verwendung des Produkts ohne Anweisungen.
- Verwendung ausserhalb der Einsatzgrenzen
- Unwirksammachen von Sicherheitseinrichtungen und Entfernen von Hinweis- und Warnschildern
- Öffnen des Produkts mit Werkzeugen (Schraubenzieher usw.)
- Durchführen von Modifikationen oder Umbauten des Geräts
- Verwendung von Zubehör anderer Hersteller, das nicht ausdrücklich empfohlen wird
- Absichtliche Blendung Dritter; auch bei Dunkelheit
- Ungenügende Absicherung des Messstandortes (z.B. bei der Durchführung von Messungen an Strassen, auf Baustellen usw.)
- Bewusstes oder leichtsinniges Hantieren auf Gerüsten, beim Besteigen von Leitern, beim Messen in der Nähe laufender Maschinen oder offener Maschinenelemente oder Anlagen
- Direktes Zielen in die Sonne

### Gebrauchsgefahren

#### **WARNUNG**

Vorsicht vor fehlerhaften Messungen beim Verwenden eines defekten Produkts, nach einem Sturz oder sonstigen unzulässigen Beanspruchungen bzw. Veränderungen am Produkt. Regelmässige Kontrollmessungen durchführen, besonders nach übermässiger Beanspruchung des Geräts sowie vor und nach wichtigen Messaufgaben.

#### **VORSICHT**

Keine Reparaturen am Produkt durchführen. Bei Defekten wenden Sie sich bitte an Ihren Händler.

#### **WARNUNG**

Nicht ausdrücklich genehmigte Änderungen oder Modifikationen können das Recht des Anwenders einschränken, das Gerät in Betrieb zu nehmen.

### Einsatzgrenzen

 Siehe Abschnitt "Technische Daten". Das Produkt ist für den Einsatz in dauernd von Menschen bewohnbaren Gebieten ausgelegt. Das Produkt darf nicht in einer explosionsgefährdeten oder aggressiven Umgebung eingesetzt werden.

### Entsorgung

#### **VORSICHT**

Leere Batterien dürfen nicht über den Hausmüll entsorgt werden. Gebrauchte Batterien zur umweltgerechten Entsorgung gemäss nationaler oder lokaler Vorschriften an den dafür vorgesehenen Sammelstellen abgeben.

Das Gerät darf nicht im Hausmüll entsorgt werden.

Gerät sachgemäss entsorgen. Länderspezifische Entsorgungsvorschriften befolgen.



Gerätespezifische Informationen zur Behandlung und Entsorgung stehen auf unserer Homepage zum Download bereit.

### Elektromagnetische Verträglichkeit (EMV)

#### **WARNUNG**

Das Gerät erfüllt die strengen Anforderungen der einschlägigen Normen und Richtlinien.

Trotzdem kann die Möglichkeit einer Störung anderer Geräte nicht gänzlich ausgeschlossen werden.

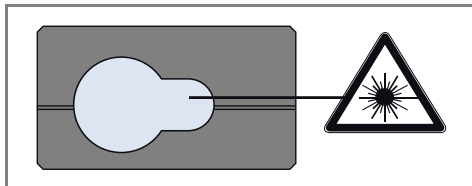
**Laserklassifizierung**

Das Gerät erzeugt sichtbare Laserstrahlen.

Das Gerät entspricht der Laserklasse 2 gemäss:

- IEC60825-1: 2007 "Sicherheit von Laseranlagen"

**Produkte der Laserklasse 2:**

Nicht in den Laserstrahl blicken und Strahl nicht unnötigerweise auf andere Personen richten. Der Schutz des Auges wird üblicherweise durch Abwendungsreaktionen einschliesslich des Lidschlussreflexes bewirkt.

**⚠️ WARNUNG**

Der direkte Blick in den Strahl mit optischen Hilfsmitteln (z. B. Ferngläser, Fernrohre) kann gefährlich sein.

**⚠️ VORSICHT**

Der Blick in den Laserstrahl kann für die Augen gefährlich sein.

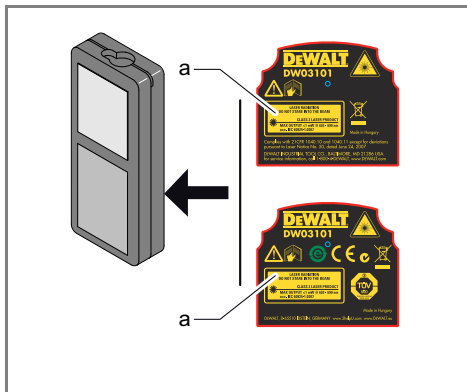
**Beschilderung**

Kleber (a) mit der Laserwarnung in Ihrer Landessprache anbringen.

# Sommaire

<b>Avant de démarrer l'appareil</b> .....	<b>2</b>
Introduction .....	2
Vue d'ensemble .....	2
Ecran .....	3
Mise en place des piles .....	3
<b>Utiliser l'appareil</b> .....	<b>4</b>
Mise sous / hors tension .....	4
Suppression .....	4
Codes de message .....	4
Réglage de la référence de mesure / trépied .....	4
Pièce finale multifonctionnelle .....	5
Réglage des unités de mesure de distance .....	5
Réglage des unités d'inclinaison .....	5
Retardateur de mesure (déclencheur automatique) .....	5
Bip actif / inactif .....	6
Eclairage actif / inactif .....	6
<b>Fonctions de mesure</b> .....	<b>7</b>
Mesure d'une distance simple .....	7
Mesure continue / minimum-maximum .....	7
Addition / Soustraction .....	7
Surface .....	8
Volume .....	9
Surface triangulaire .....	10
Pythagore (2 points) .....	11
Pythagore (3 points) .....	11
Pythagore (hauteur partielle) .....	12
Piquetage .....	13
Mode horizontal intelligent .....	13
Poursuite latérale .....	14
Calage à l'horizontale .....	14
Mémoire (20 derniers affichages) .....	15

Vider la mémoire .....	15
------------------------	----

## Calibrage .....

Calibrage du capteur d'inclinaison (calibrage de l'inclinaison) .....	16
--	----

## Caractéristiques techniques .....

## Codes de message .....

## Entretien .....

## Garantie .....

## Consignes de sécurité .....

Responsabilité .....	18
Utilisation conforme .....	19
Utilisation non conforme .....	19
Risques liés à l'utilisation .....	19
Conditions d'application .....	19
Tri sélectif .....	19
Compatibilité électromagnétique (CEM) .....	19
Déclaration FCC (applicable aux Etats-Unis) .....	20
Classification laser .....	20
Signalisation .....	20

## Introduction

 Veuillez lire attentivement les consignes de sécurité et le manuel avant d'utiliser le produit pour la première fois.

 Le responsable du produit doit s'assurer que tous les utilisateurs comprennent et respectent les consignes qui suivent.

Les symboles utilisés ont la signification suivante:

** ATTENTION**

Indique une situation potentiellement périlleuse pouvant entraîner de graves blessures voire la mort si elle n'est pas évitée.

** PRUDENCE**

Risque ou utilisation non conforme susceptible de provoquer des dommages dont l'étendue est faible au niveau corporel, mais peut être importante au niveau matériel, financier ou écologique.

 Paragraphes importants auxquels il convient de se référer en pratique car ils permettent d'utiliser le produit de manière efficace et techniquement correcte.

## Vue d'ensemble

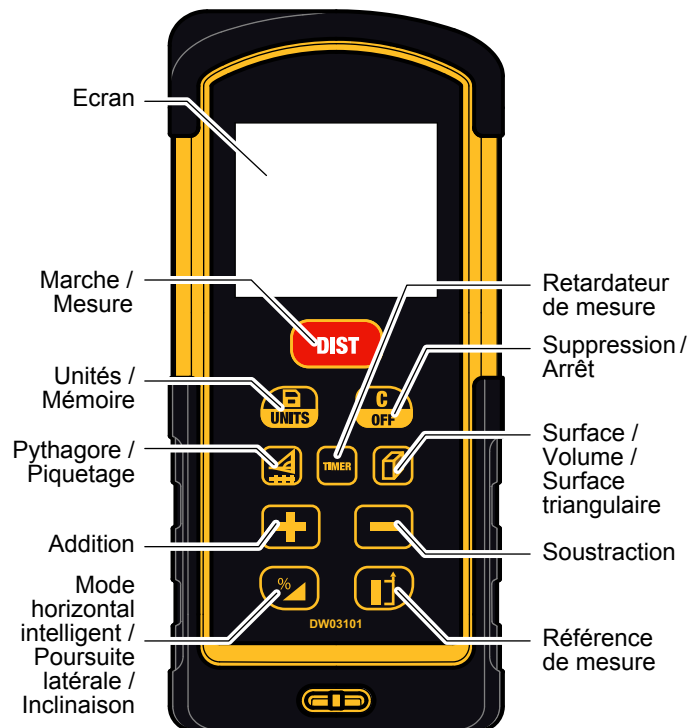

# Avant de démarrer l'appareil

## Ecran

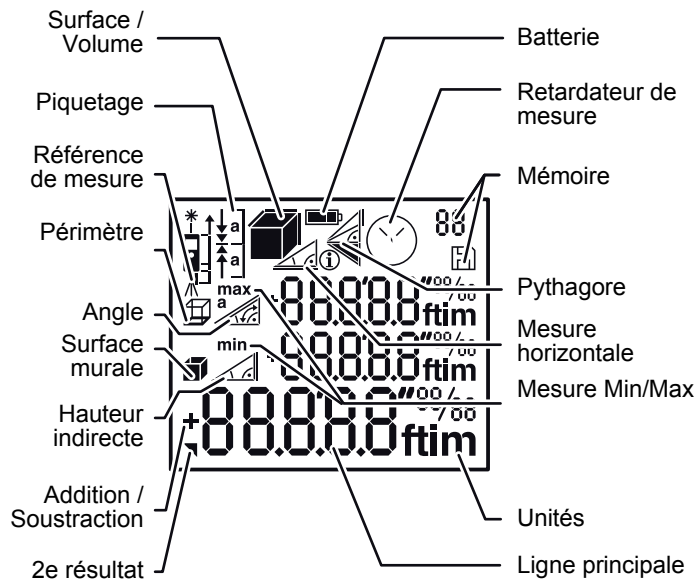

## Mise en place des piles

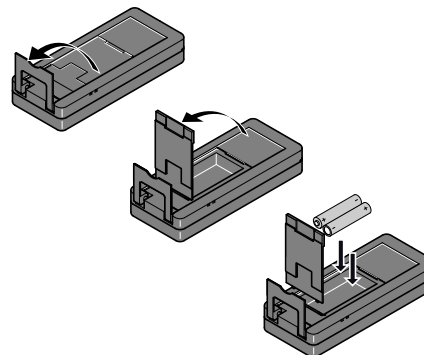

i

Pour bénéficier d'un fonctionnement optimal, ne pas utiliser des piles au zinc-carbone. Remplacer les piles quand le symbole correspondant clignote.

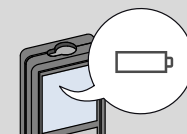

# Utiliser l'appareil

## Mise sous / hors tension



2 s

Appareil hors tension.

i

Presser le bouton ON 2 s pour activer le mode laser continu. Si aucune touche n'est actionnée pendant 180 s, l'appareil s'éteint tout seul.

## Suppression

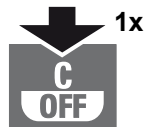

1x

Annuler la dernière action.

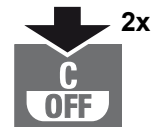

2x

Quitter la fonction courante. Activer le mode par défaut.

## Codes de message

Si l'icône Info s'affiche avec un nombre, suivre les instructions de la section "Codes de message".  
Exemple:



## Réglage de la référence de mesure / trépied

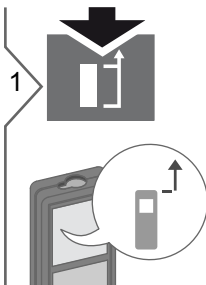

Distance mesurée depuis la face avant de l'appareil.

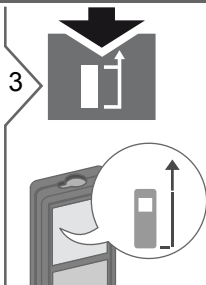
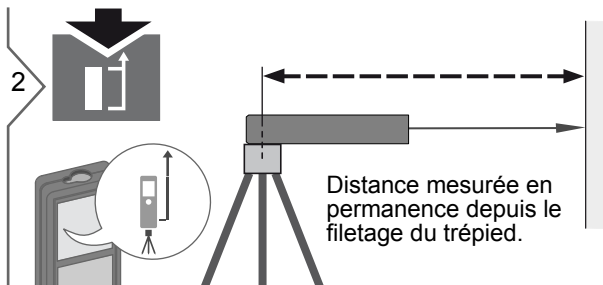

Distance mesurée depuis la face arrière de l'appareil (réglage par défaut).

# Utiliser l'appareil

## Pièce finale multifonctionnelle

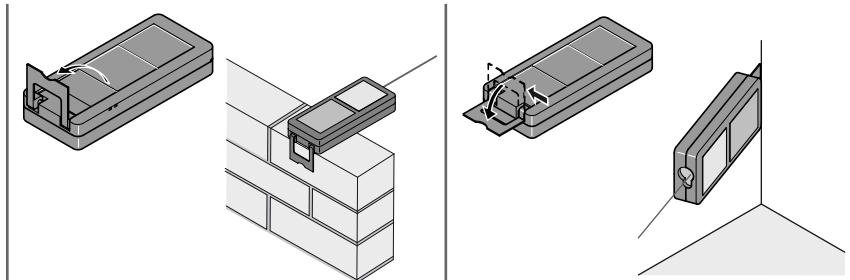

**i** L'orientation de la pièce finale est automatiquement détectée et le point zéro ajusté en conséquence.

## Réglage des unités de mesure de distance

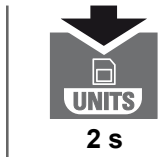

Commuter entre les unités de mesure suivantes:

0.000 m	0.00 ft
0.0000 m	0'00" 1/32
0.00 m	0.00 in
	0 in 1/32

## Réglage des unités d'inclinaison

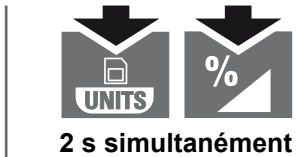

Commuter entre les unités de mesure suivantes:

180 °
0.0 %

## Retardateur de mesure (déclencheur automatique)

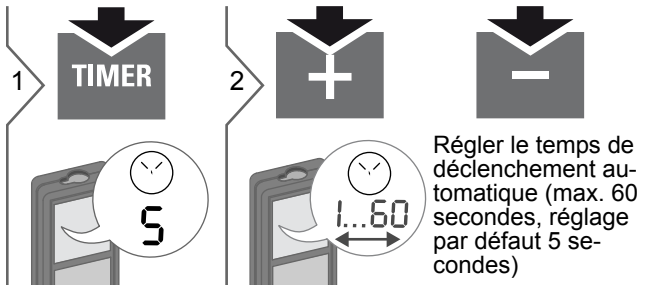

**i** Après le relâchement de la touche avec le laser activé, les secondes restantes jusqu'à la mesure sont décomptées et indiquées à l'écran. Il est recommandé de retarder le déclenchement par ex. pour une visée précise sur de longues distances. Cela permet d'éviter de secouer l'appareil en pressant la touche de mesure.

# Utiliser l'appareil

## Bip actif / inactif



2 s  
simultanément



## Eclairage actif / inactif



2 s  
simultanément

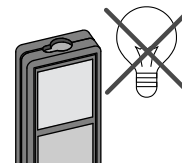
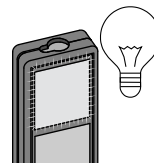

## Fonctions de mesure

### Mesure d'une distance simple

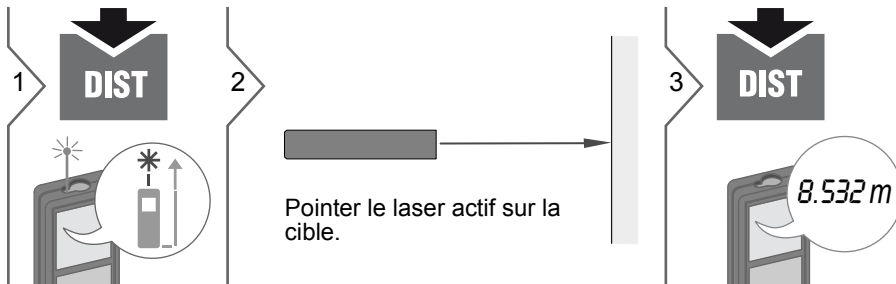

**i** Surfaces cibles: des erreurs peuvent se produire lors de mesures sur des liquides incolores, du verre, du polystyrène ou des surfaces semi-perméables ou en cas de visée de surfaces très brillantes. Lorsqu'on vise une surface sombre, le temps de mesure augmente.

### Mesure continue / minimum-maximum

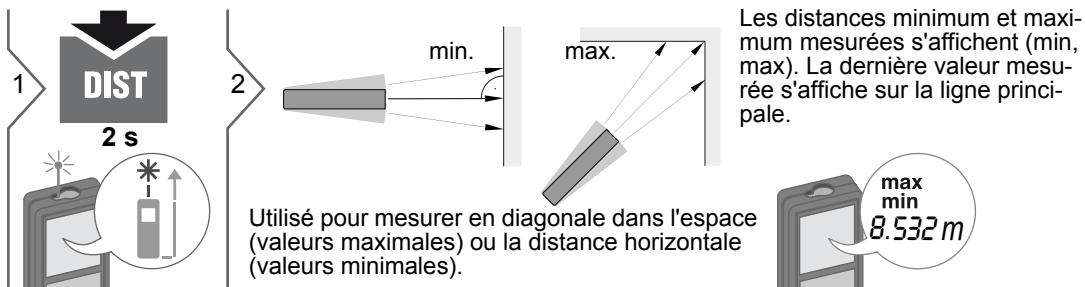

Arrête la mesure continue / minimum-maximum.

### Addition / Soustraction

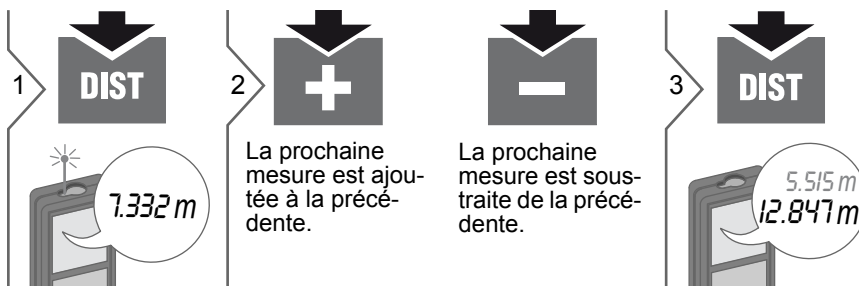

**i** Le résultat s'affiche sur la ligne principale et la valeur mesurée au-dessus. On peut répéter cette opération. On peut procéder de la même manière pour additionner ou soustraire des surfaces ou volumes.

Surface

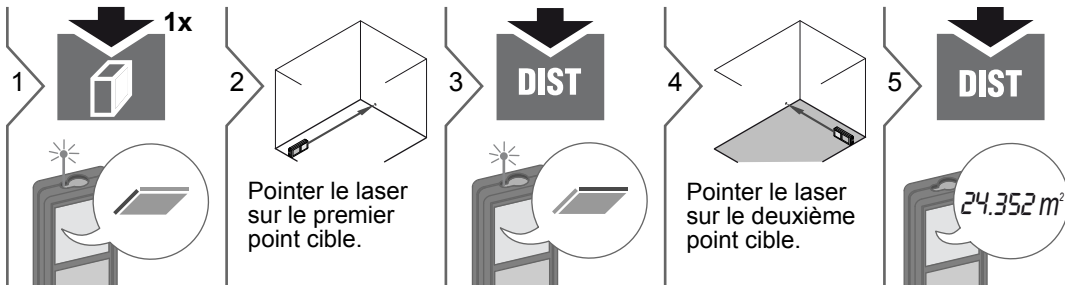

**i** Le résultat s'affiche sur la ligne principale et la valeur mesurée au-dessus.

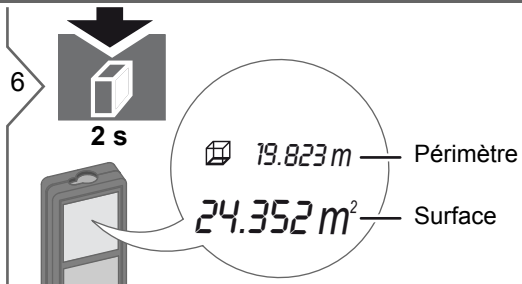

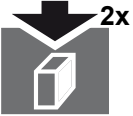
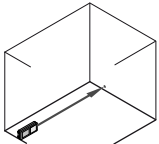

# Fonctions de mesure

## Volume

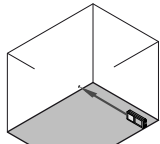

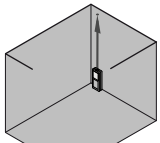
1   Pointer le laser sur le premier point cible.

2  Pointer le laser sur le deuxième point cible.

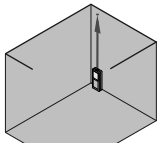

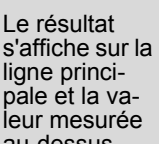
3   Pointer le laser sur le troisième point cible.

4   Pointer le laser sur le troisième point cible.

5   Pointer le laser sur le premier point cible.

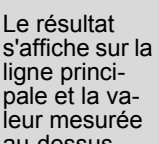
6   Pointer le laser sur le troisième point cible.

7   Pointer le laser sur le premier point cible.

8   Pointer le laser sur le troisième point cible.

Le résultat s'affiche sur la ligne principale et la valeur mesurée au-dessus.

**78.694 m<sup>3</sup>**

**80.208 m** — Périmètre  
**208.703 m<sup>2</sup>** — Surfaces murales  
**78.694 m<sup>3</sup>** — Volume

## Surface triangulaire

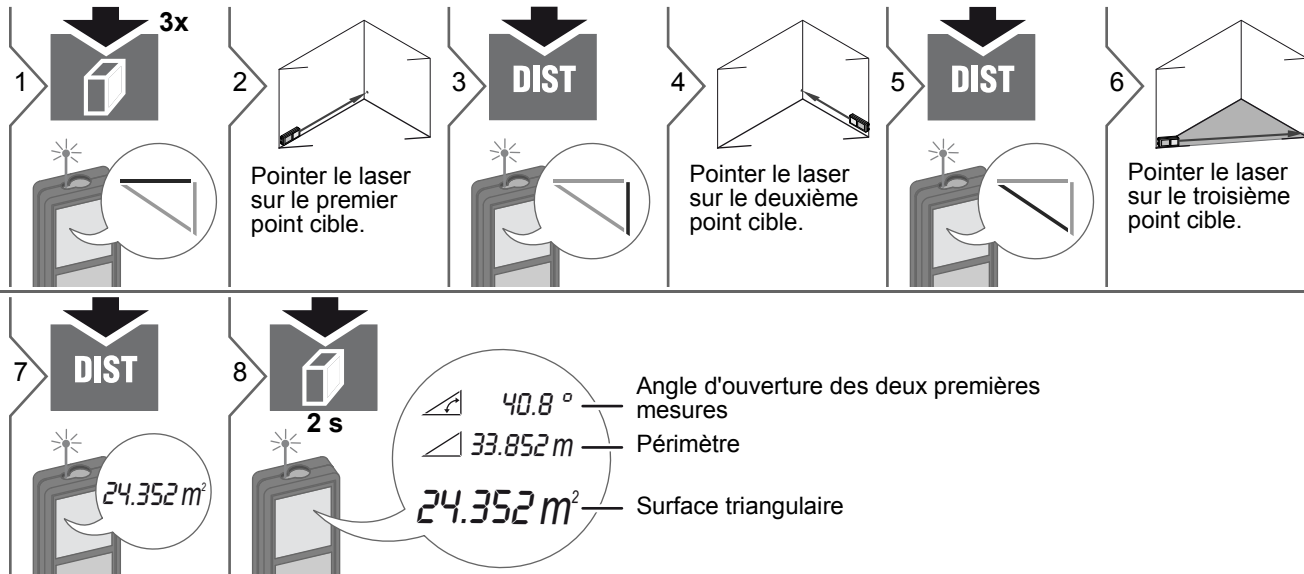

# Fonctions de mesure

## Pythagore (2 points)

1

2

Pointer le laser sur le point supérieur.

3

4

Pointer le laser à angle droit sur le point inférieur.

5

**i** Le résultat s'affiche sur la ligne principale et la distance mesurée au-dessus. Si on presse la touche de mesure pendant 2 s, la mesure minimum ou maximum est automatiquement activée.

## Pythagore (3 points)

1

2

Pointer le laser sur le point supérieur.

3

4

Pointer le laser sur le point à angle droit.

5

6

Pointer le laser sur le point inférieur.

7

**i** Le résultat s'affiche sur la ligne principale et la distance mesurée au-dessus. Si on presse la touche de mesure pendant 2 s, la mesure minimum ou maximum est automatiquement activée.

## Pythagore (hauteur partielle)

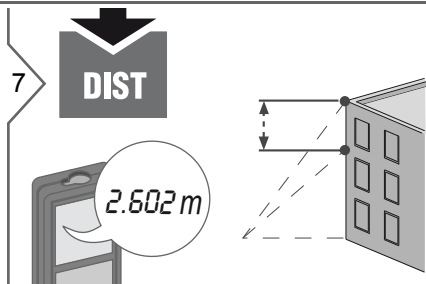

Le résultat s'affiche sur la ligne principale et la distance mesurée au-dessus.  
Si on presse la touche de mesure pendant 2 s, la mesure minimum ou maximum est automatiquement activée.

## Piquetage

1

2

3

4x

Ajuster la valeur.

0.625 m

1.000 m

0.625 m

3

**DIST**

Confirmer la valeur et démarrer la mesure.

4

Déplacer l'appareil lentement le long de la ligne de piquetage. La distance jusqu'au piquetage suivant s'affiche.

0.625 m

0.625 m

0.240 m

Il manque 0,240 m pour atteindre 0,625 m.

i

Lorsqu'on approche un piquetage à moins de 0,1 m, des bips se font entendre. Le bouton SUPPRESSION/ARRET permet d'arrêter la fonction.

## Mode horizontal intelligent

1

2

3

1x

Pointez le laser sur la cible.

**DIST**

24.3° —  $\alpha$

0.032 m —  $y$

4.827 m —  $z$

(jusqu'à 360° et une inclinaison transversale de  $\pm 10^\circ$ )

i

Appuyer de nouveau sur la touche pour arrêter la mesure à l'horizontale.

**Poursuite latérale**

Cette fonction permet d'afficher en permanence la poursuite latérale si l'appareil est tourné vers le trépied. La mesure de la 2e distance n'est nécessaire que si l'angle est mesuré automatiquement.

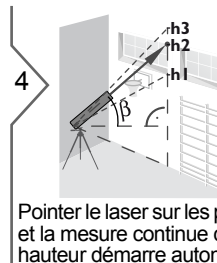
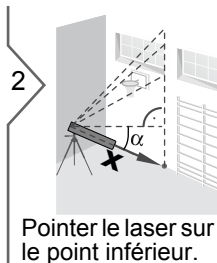
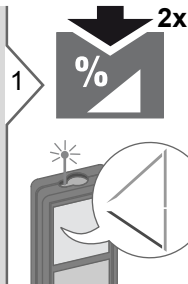

Pointer le laser sur les points supérieurs et la mesure continue de l'angle / de la hauteur démarre automatiquement.

5

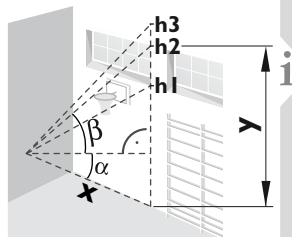
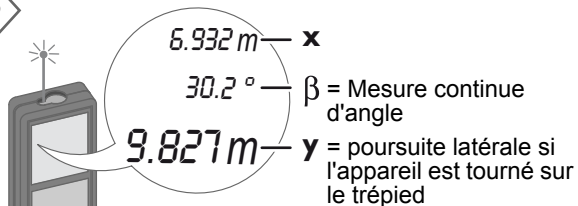

La hauteur mesurée "y" est à 90° du 1er point visé "x".

6



Arrête la poursuite latérale et affiche la dernière mesure.

**Calage à l'horizontale**

Cette fonction affiche en continu l'inclinaison de l'appareil. A partir d'une inclinaison de  $\pm 5^\circ$ , l'appareil commence à émettre des bips fréquents. Plus il se rapproche de  $0^\circ$ , plus les bips sont rapides. Quand l'inclinaison atteint  $\pm 0,3^\circ$ , l'appareil émet un bip continu.

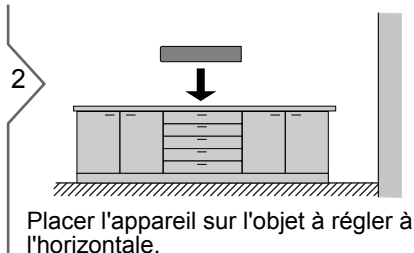
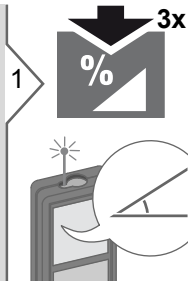

L'inclinaison est affichée (plage  $\pm 180^\circ$ ).

## Fonctions de mesure

### Mémoire (20 derniers affichages)

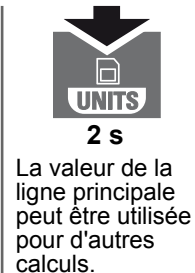
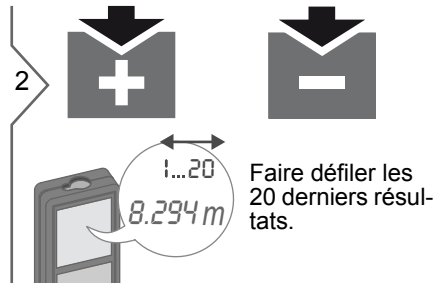
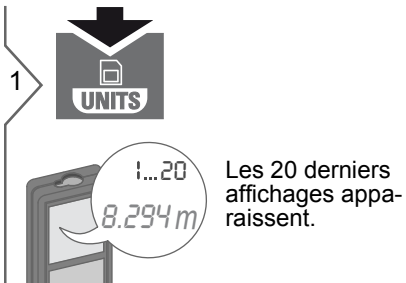

### Vider la mémoire

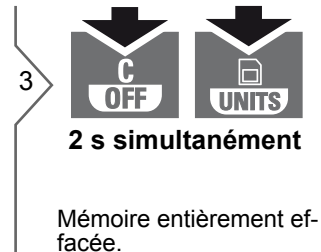

# Calibrage

## Calibrage du capteur d'inclinaison (calibrage de l'inclinaison)

1  2 s simultanément

MEAS 1  
HOR  
CAL

2 Placer l'appareil sur une surface toute plane.

3  DIST

MEAS 2  
turn  
180°

4  DIST

180°

Tourner l'appareil horizontalement à 180° et le replacer sur une surface toute plane.

5  DIST

MEAS 3  
VER  
CAL

6 Retourner l'appareil et le replacer sur une surface toute plane.

7  DIST

MEAS 4  
turn  
180°

8  DIST

180°

Tourner l'appareil horizontalement à 180° et le replacer sur une surface toute plane.

9  DIST

OK  
CAL

 Au bout de 2 secondes, l'appareil se remet en mode normal.

Mesure de la distance	
<b>Tolérance de mesure type*</b>	± 1,0 mm / 0,04 in ***
<b>Tolérance de mesure maximale **</b>	± 2,0 mm / 0,08 in ***
<b>Portée de la plaque de mire</b>	100 m / 330 ft
<b>Portée type *</b>	80 m / 262 ft
<b>Portée dans des conditions défavorables ****</b>	60 m / 197 ft
<b>Plus petite unité de mesure affichée</b>	0,1 mm / 1/32 in
<b>Ø du point laser à</b>	6 / 30 / 60 mm (10 / 50 / 100 m)
Mesure de l'inclinaison	
<b>Tolérance de mesure par rapport au faisceau laser****</b>	± 0,2°
<b>Tolérance de mesure par rapport au boîtier*****</b>	± 0,2°
<b>Portée</b>	360°
Informations générales	
<b>Classe laser</b>	2
<b>Type de laser</b>	635 nm, < 1 mW
<b>Divergence de faisceau</b>	0,16 x 0,6 mrad
<b>Durée d'impulsion</b>	0,2 x 10 <sup>-9</sup> s - 0,8 x 10 <sup>-9</sup> s
<b>Classe de protection</b>	IP54 (protection contre la poussière et l'eau de ruissellement)
<b>Arrêt autom. du laser</b>	au bout de 90 s
<b>Arrêt automatique</b>	au bout de 180 s
<b>Durée de vie des piles (2 x AAA)</b>	jusqu'à 5000 mesures
<b>Dimensions (H x P x L)</b>	125,2 x 58 x 32,6 mm 4,9 x 2,3 x 1,3 in
<b>Poids (avec piles)</b>	154 g / 5,43 oz
<b>Plage de température:</b>	
- Stockage	-25 à 70 °C -13 à 158 °F
- Service	-10 à 50 °C 14 à 122 °F

\* s'applique à une réflectivité de la cible de 100 % (mur peint en blanc), luminosité de fond faible, 25 °C

\*\* s'applique à une réflectivité de la cible de 10 à 500 %, luminosité de fond élevée, - 10 °C à + 50 °C

\*\*\* Les tolérances s'appliquent sur des distances de 0,05 m à 10 m avec un niveau de fiabilité de 95 %. La tolérance maximale peut se dégrader de 0,1 mm/m sur des distances de 10 m à 30 m et de 0,2 mm sur des distances supérieures à 30 m.

\*\*\*\* s'applique à une réflectivité de la cible de 100 %, luminosité de fond d'environ 30 000 lux

\*\*\*\*\* après calibrage par l'utilisateur. Angle additionnel relatif à un écart de +/- 0,01° par degré jusqu'à +/-45° dans chaque quart de cercle. S'applique à la température ambiante. L'écart maximal augmente à +/- 0,1° pour toute la plage de température de service.

**i** Pour obtenir des résultats indirects précis, il est recommandé d'utiliser un trépied. Pour obtenir des mesures précises de l'inclinaison, éviter une inclinaison transversale.

Fonctions	
<b>Mesure de la distance</b>	oui
<b>Mesure Min / Max</b>	oui
<b>Mesure continue</b>	oui
<b>Piquetage</b>	oui
<b>Addition / Soustraction</b>	oui
<b>Surface</b>	oui
<b>Volume</b>	oui
<b>Pythagore</b>	2 points, 3 points, hauteur partielle
<b>Mode horizontal intelligent / Hauteur indirecte</b>	oui
<b>Poursuite latérale</b>	oui
<b>Calage à l'horizontale</b>	oui
<b>Mémoire</b>	20 affichages
<b>Bip</b>	oui
<b>Rétroéclairage</b>	oui
<b>Pièce finale multifonctionnelle</b>	oui

## Codes de message

Si le message **Erreur** ne disparaît pas après une mise sous tension répétée de l'appareil, contacter le revendeur.

Si le message **InFo** s'affiche avec un nombre, presser le bouton Clear et suivre les instructions suivantes:

N°	Cause	Correction
156	Inclinaison transversale supérieure à 10°	Maintenir l'appareil sans inclinaison transversale.
162	Erreur de calibrage	Veiller à ce que l'appareil soit placé sur une surface parfaitement horizontale et plane. Répéter l'opération de calibrage. Si l'erreur persiste, contacter le fournisseur.
204	Erreur de calcul	Réexécuter la mesure.
252	Température trop haute	Laisser refroidir l'appareil.
253	Température trop basse	Réchauffer l'appareil.
255	Signal reçu trop faible, temps de mesure trop long	Changer la surface cible (par ex. papier blanc).
256	Signal reçu trop fort	Changer la surface cible (par ex. papier blanc).
257	Trop forte luminosité	Mettre la zone cible à l'ombre.
258	Mesure hors plage	Corriger la mesure.
260	Faisceau laser interrompu	Répéter la mesure.

## Entretien

- Nettoyer l'appareil avec un chiffon doux, humide.
- Ne jamais tremper l'appareil dans l'eau.
- Ne jamais utiliser d'agents nettoyants ou de solvants agressifs.

## Garantie

### Europe:

- Garantie 30 jours "satisfait ou remboursé"
- Un an de maintenance gratuite
- Un an de garantie totale

Des informations détaillées sont disponibles sur le site Internet [www.2helpU.com](http://www.2helpU.com).

### Amérique du Nord:

- Trois ans de garantie limitée
- Un an de maintenance gratuite
- Garantie 90 jours "satisfait ou remboursé"

Des informations détaillées sont disponibles sur le site Internet [www.dewalt.com](http://www.dewalt.com).

## Consignes de sécurité

Le responsable du produit doit s'assurer que tous les utilisateurs comprennent et respectent les consignes qui suivent.

### Responsabilité

#### Responsabilité du fabricant de l'équipement original:

Europe:

DEWALT

D-65510 Idstein, Germany

[www.2helpU.com](http://www.2helpU.com)

[www.dewalt.eu](http://www.dewalt.eu)

Amérique du Nord:

DEWALT Industrial Tool Co.

Baltimore, MD21286, USA

Pour le SAV, appeler le 1-800-4-DEWALT.

[www.dewalt.com](http://www.dewalt.com)

L'entreprise mentionnée ci-dessus est tenue de livrer le produit, et le manuel d'utilisation, en parfait état. L'entreprise mentionnée ci-dessus ne peut être tenue pour responsable des accessoires fournis par des tiers.

#### Responsabilité du responsable du produit:

- Comprendre les informations de sécurité inscrites sur le produit et les instructions du manuel d'utilisation.
- Connaître les consignes de sécurité locales en matière de prévention des accidents.
- Toujours rendre le produit inaccessible à du personnel non autorisé à l'utiliser.

## Consignes de sécurité

### Utilisation conforme

- Mesure de distances
- Mesure de l'inclinaison

### Utilisation non conforme

- Mettre le produit en service sans instructions préalables
- L'utiliser en dehors des limites définies
- Rendre les installations de sécurité inefficaces et enlever les plaques signalétiques ainsi que les avertissements
- Ouvrir le produit avec des outils (par ex. tournevis)
- Modifier ou transformer le produit
- Utiliser des accessoires d'autres fabricants sans autorisation expresse
- Eblouir intentionnellement des tiers, même dans l'obscurité
- Prendre des précautions insuffisantes sur le lieu de mesure (par ex. exécution de mesures au bord de routes, sur des chantiers)
- Manipuler volontairement ou non sans précautions le produit sur des échafaudages, des escaliers à proximité de machines en marche ou d'installations non protégées
- Viser en plein soleil

### Risques liés à l'utilisation

#### ATTENTION

En cas de chutes, de sollicitations extrêmes ou d'adaptations non autorisées, le produit peut présenter des dommages et fournir des mesures incorrectes. Effectuer périodiquement des mesures de contrôle, surtout lorsque le produit a été sollicité de façon inhabituelle, et avant, pendant et après des mesures importantes.

#### PRUDENCE

N'effectuer en aucun cas soi-même des réparations sur le produit. En cas d'endommagement, contacter un revendeur local.

#### ATTENTION

Les modifications non expressément approuvées peuvent invalider le droit de mise en œuvre accordé à l'utilisateur.

### Conditions d'application

 Cf. chapitre "Caractéristiques techniques".

L'appareil est conçu pour être utilisé dans des milieux pouvant être habités en permanence par l'homme. Le produit n'a pas le droit d'être utilisé dans un environnement explosif ou agressif.

### Tri sélectif

#### ATTENTION

Ne pas jeter les piles déchargées avec les ordures ménagères. Les amener à un point de collecte prévu à cet effet pour une élimination conforme aux prescriptions environnementales nationales ou locales. Ne pas jeter le produit avec les ordures ménagères.

Eliminer le produit conformément aux prescriptions nationales en vigueur dans le pays d'utilisation. Suivre les règles de recyclage en vigueur sur le plan national, spécifiques au produit.

Il est possible de télécharger des informations sur le traitement des déchets spécifiques au produit sur notre site Internet.

### Compatibilité électromagnétique (CEM)

#### ATTENTION

L'appareil est conforme aux dispositions les plus strictes des normes et réglementations concernées.

Un risque de perturbation du fonctionnement d'autres appareils ne peut cependant être tout à fait exclu.



## Consignes de sécurité

### Déclaration FCC (applicable aux Etats-Unis)

Cet équipement a été testé et jugé conforme aux valeurs limites établies pour un appareil numérique de classe B, sur la base de la partie 15 des règles FCC. Ces limites sont prévues pour garantir une protection raisonnable contre des interférences néfastes dans une installation résidentielle. Cet équipement génère, utilise et peut rayonner de l'énergie radiofréquence et, s'il n'est pas installé ou utilisé conformément aux instructions, il peut gravement perturber des communications radio. Il est cependant impossible d'exclure des interférences dans une installation donnée, même en cas de respect des instructions. Si cet équipement perturbe gravement la réception radio ou télévision, ce que l'on peut déterminer en éteignant puis en rallumant l'équipement, l'utilisateur est invité à essayer de corriger ces interférences en appliquant une ou plusieurs mesures exposées ci-après:

- Réorienter ou repositionner l'antenne réceptrice.
- Augmenter la distance entre l'équipement et le récepteur.
- Raccorder l'équipement à une prise d'un circuit différent de celui sur lequel est branché le récepteur.
- Consulter le revendeur ou un technicien radio/TV expérimenté pour obtenir de l'aide.

### Classification laser

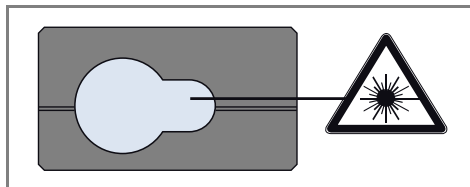

L'appareil génère des faisceaux laser visibles:  
C'est un produit laser de classe 2 conformément à:

- CEI60825-1: 2007 "Sécurité du rayonnement d'appareils à laser"

### Produits laser de classe 2:

Ne pas regarder dans le faisceau laser et ne pas le projeter inutilement sur des personnes. La protection de l'œil est en général assurée par des mouvements réflexes tels que la fermeture des paupières.

### ⚠ ATTENTION

Une observation directe du faisceau laser avec des instruments optiques (jumelles, lunettes, etc.) peut s'avérer dangereuse.

### ⚠ PRUDENCE

Regarder dans le faisceau laser peut s'avérer dangereux pour l'œil.

### Signalisation

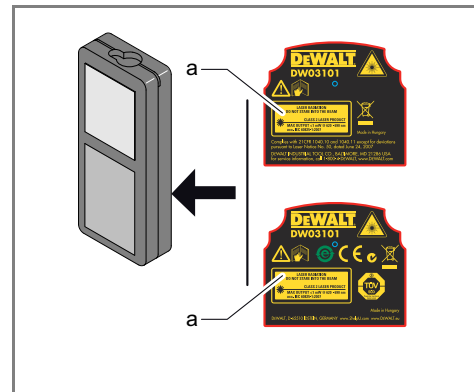



Appliquer l'étiquette laser (a) dans la langue de votre pays.

# Indice

<b>Impostazione dello strumento</b> .....	<b>2</b>	Memoria (ultimi 20 valori) .....	15
Introduzione .....	2	Cancellazione	
Descrizione generale .....	2	della memoria .....	15
Display .....	3	<b>Calibrazione</b> .....	<b>16</b>
Inserimento delle batterie .....	3	Calibrazione del sensore di inclinazione	
<b>Operazioni</b> .....	<b>4</b>	(calibrazione di inclinazione) .....	16
Accensione/Spegnimento .....	4	<b>Dati tecnici</b> .....	<b>17</b>
Clear (Annulla) .....	4	<b>Codici dei messaggi</b> .....	<b>18</b>
Codici dei messaggi .....	4	<b>Cura</b> .....	<b>18</b>
Impostazione del riferimento di misura /		<b>Garanzia</b> .....	<b>18</b>
del treppiede .....	4	<b>Istruzioni per la sicurezza</b> .....	<b>18</b>
Adattatore multifunzione .....	5	Ambiti di responsabilità .....	18
Impostazione delle unità della distanza .....	5	Uso consentito .....	19
Impostazione delle unità dell'inclinazione .....	5	Uso non consentito .....	19
Timer (rilascio automatico) .....	5	Pericoli insiti nell'uso .....	19
Beep ON/OFF .....	6	Limiti all'uso .....	19
Illuminazione ON/OFF .....	6	Smaltimento .....	19
<b>Funzioni di misura</b> .....	<b>7</b>	Compatibilità elettromagnetica (EMC) .....	19
Misura di una distanza singola .....	7	Classificazione laser .....	20
Misura permanente / minima-massima .....	7	Etichette .....	20
Addizione / Sottrazione .....	7		
Superficie .....	8		
Volume .....	9		
Superficie triangolare .....	10		
Pitagora (2 punti) .....	11		
Pitagora (3 punti) .....	11		
Pitagora (altezza parziale) .....	12		
Tracciamento .....	13		
Smart Horizontal Mode .....	13		
Tracciamento altezza .....	14		
Livellamento in corso .....	14		

### Introduzione

 Prima di utilizzare lo strumento per la prima volta leggere attentamente le istruzioni di sicurezza e il manuale d'uso.

 La persona responsabile dello strumento deve accertarsi che tutti gli operatori comprendano e rispettino le istruzioni di sicurezza.

I simboli utilizzati hanno il seguente significato:

#### **AVVERTENZA**

Situazione potenzialmente pericolosa o uso improprio che, se non evitati, potrebbero causare la morte o lesioni gravi.

#### **ATTENZIONE**

Situazione potenzialmente pericolosa o uso non consentito che possono causare lesioni lievi alle persone e gravi danni materiali, economici o ambientali.

**i** Introduce indicazioni importanti a cui bisogna attenersi per usare lo strumento in modo tecnicamente corretto ed efficiente.

### Descrizione generale

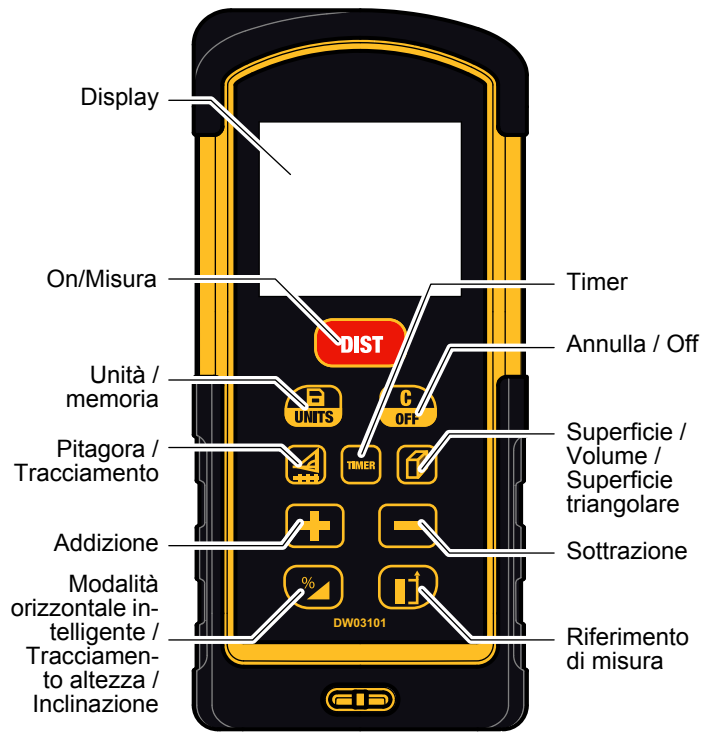

# Impostazione dello strumento

## Display

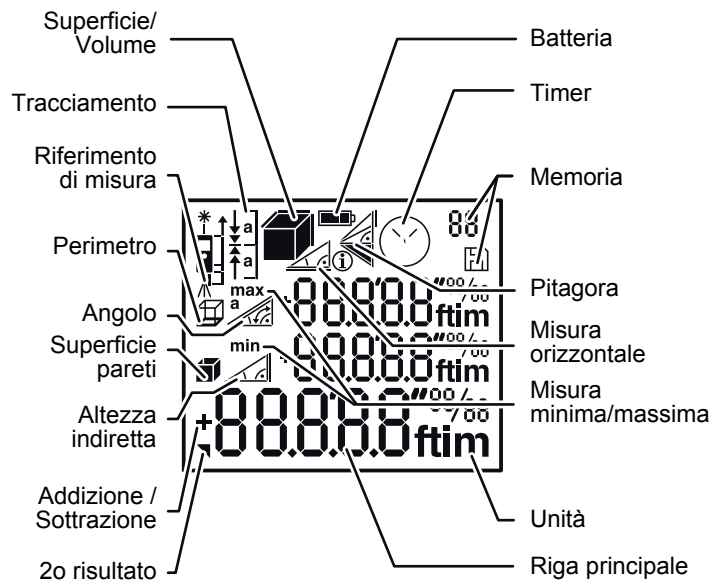

## Inserimento delle batterie

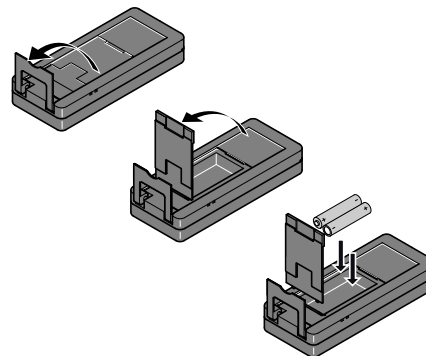

i

Per garantire un funzionamento affidabile non usare batterie allo zinco-carbone. Sostituire le batterie quando il simbolo lampeggia.

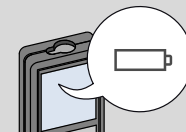

# Operazioni

## Accensione/Spegnimento



Il dispositivo è spento.

i

Premere il tasto ON per 2 secondi per avviare la modalità continua. Se non si preme il tasto entro 180 s., il dispositivo si spegne automaticamente.

## Clear (Annulla)

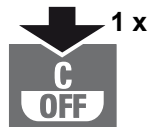

Annulla l'ultima operazione.

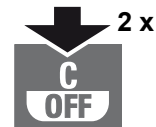

Lascia la funzione attuale, passa alla modalità operativa di default.

## Codici dei messaggi

Se l'icona "InFo" compare con un numero consultare le istruzioni nel capitolo "Codici dei messaggi". Esempio:



## Impostazione del riferimento di misura / del treppiede

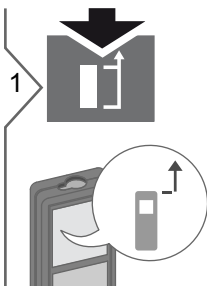

La distanza viene misurata dal lato anteriore del dispositivo.

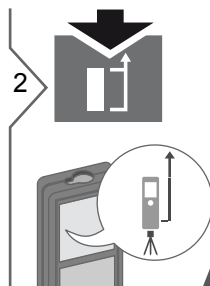

La distanza viene misurata dalla filettatura del treppiede in modo permanente.

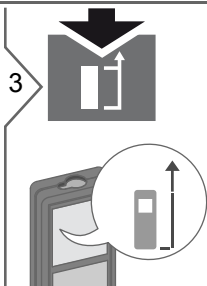

La distanza viene misurata dal lato posteriore del dispositivo (impostazione di default).

## Operazioni

### Adattatore multifunzione

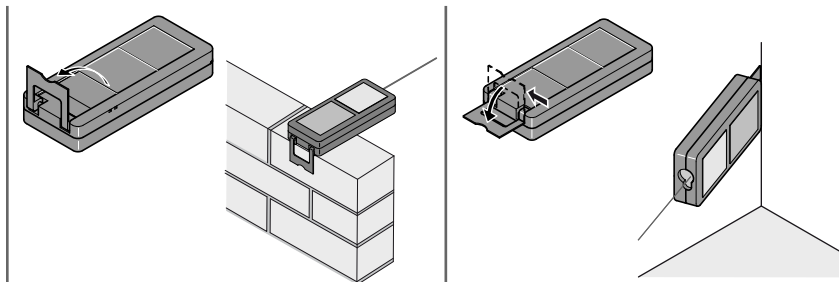

**i** L'orientamento dell'adattatore viene rilevato automaticamente e il punto zero viene impostato di conseguenza.

### Impostazione delle unità della distanza



**2 s**

Per passare tra le seguenti unità:

0.000 m	0.00 ft
0.0000 m	0'00" 1/32
0.00 m	0.00 in
	0 in 1/32

### Impostazione delle unità dell'inclinazione



**2 s simultaneamente**

Per passare tra le seguenti unità:

180 °
0.0 %

### Timer (rilascio automatico)

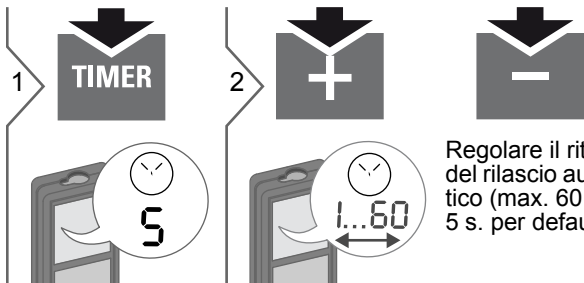

Regolare il ritardo del rilascio automatico (max. 60 s., 5 s. per default)

**i** Quando si rilascia il tasto con il laser attivo compare il conto alla rovescia dei secondi che mancano alla misura. Può essere utile impostare il rilascio ritardato per ottenere un puntamento preciso ad es. a distanze elevate. Evita infatti che il dispositivo vibri quando si preme il tasto per la misura.

## Operazioni

### Beep ON/OFF



2 s simultanea-  
mente

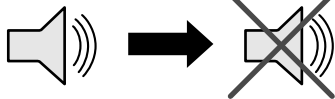

### Illuminazione ON/OFF



2 s simultanea-  
mente

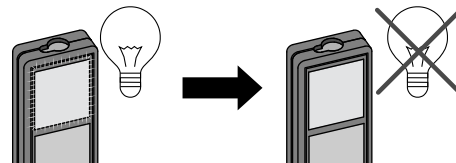

## Funzioni di misura

### Misura di una distanza singola

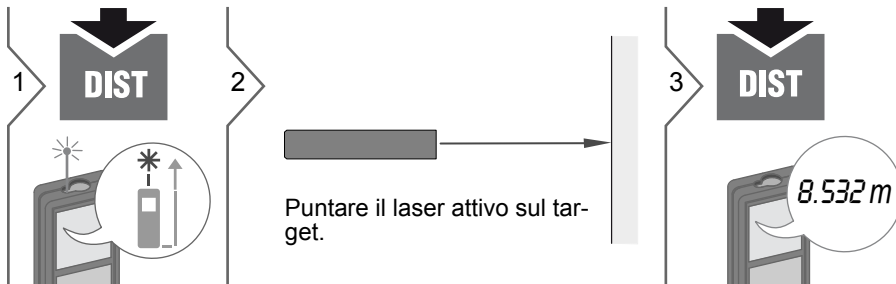

**i** Superfici target: se si misura la distanza da liquidi incolore, vetro, polistirolo o superfici semipermeabili o si punta su superfici molto lucide possono verificarsi errori di misura. Se si punta su superfici scure il tempo di misura aumenta.

### Misura permanente / minima-massima

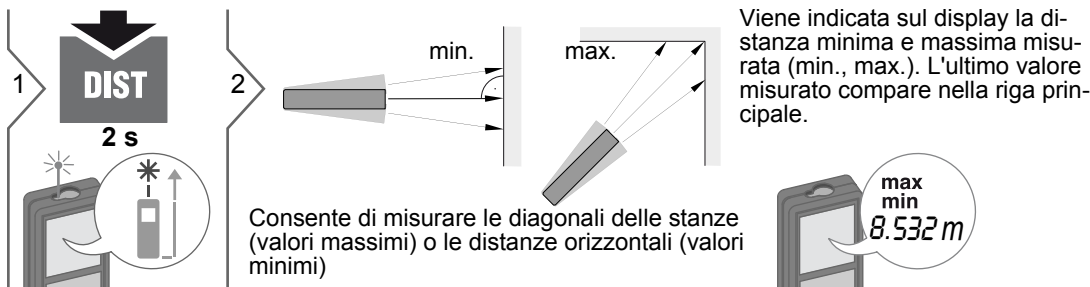

Arresta la misura permanente / minima-massima.

### Addizione / Sottrazione

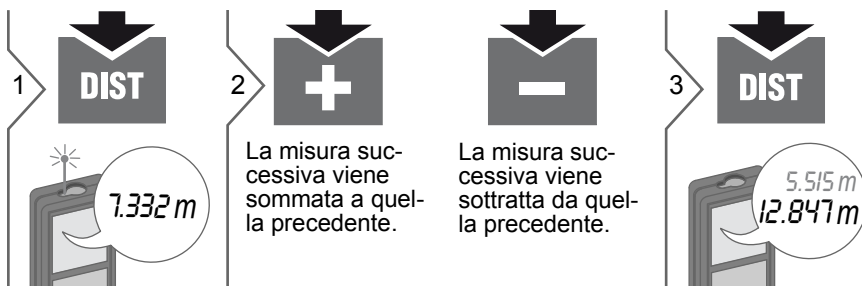

**i** Il risultato viene indicato nella riga principale e il valore misurato in quella precedente. Se necessario la procedura può essere ripetuta. La stessa operazione consente di sommare e sottrarre superfici o volumi.

Superficie

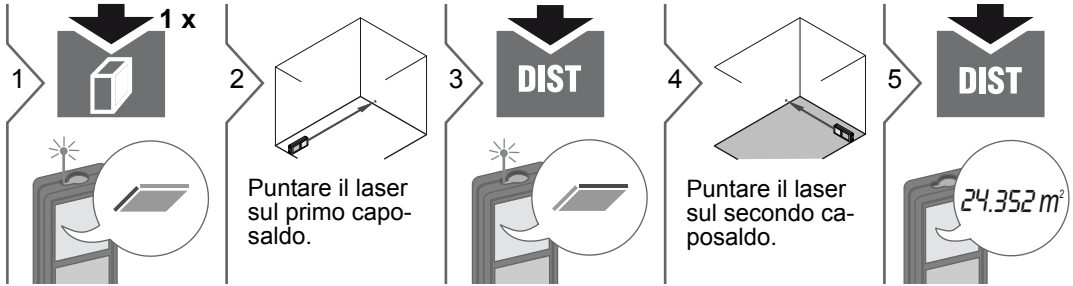

**i** Il risultato viene indicato nella riga principale e il valore misurato in quella precedente.

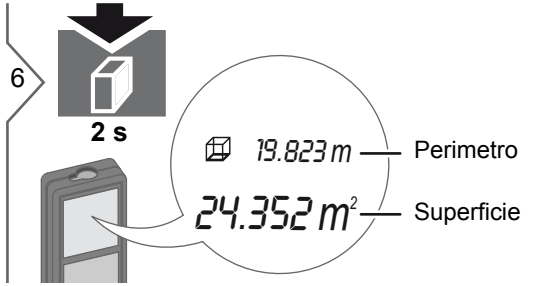

# Funzioni di misura

## Volume

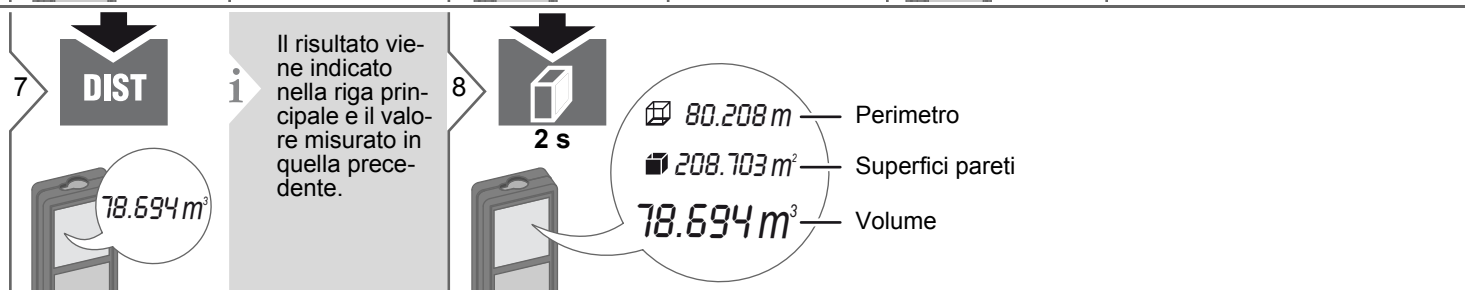
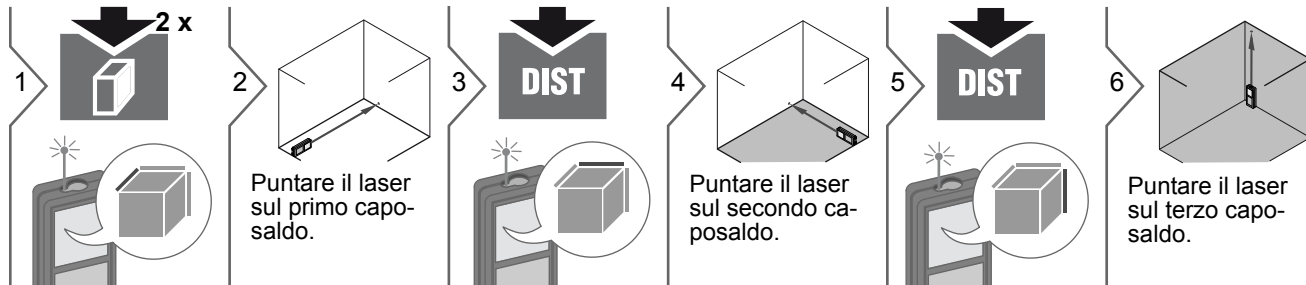

### Superficie triangolare

1 

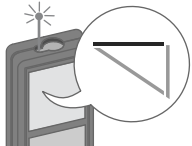

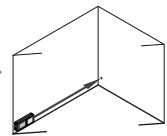
2 

Puntare il laser sul primo caposaldo.

3 

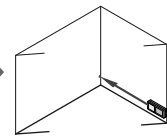

4 

Puntare il laser sul secondo caposaldo.

5 



6 

Puntare il laser sul terzo caposaldo.

7 

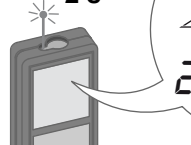
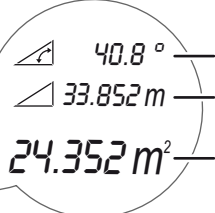

8 

- $40.8^\circ$  — Angolo compreso tra le prime due misure
- $33.852\text{ m}$  — Perimetro
- $24.352\text{ m}^2$  — Superficie triangolare

# Funzioni di misura

## Pitagora (2 punti)

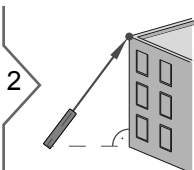
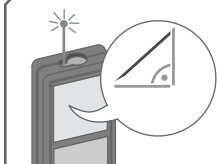

Puntare il laser sul punto superiore.

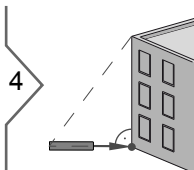
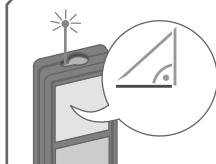

Puntare il laser perpendicolarmente al punto più basso.

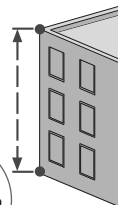

i

Il risultato viene indicato nella riga principale e la distanza misurata sopra a questa. Premendo il tasto di misura per 2 s in questa funzione si attiva automaticamente la misura minima o massima.

## Pitagora (3 punti)

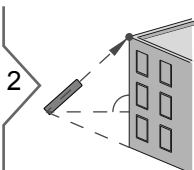
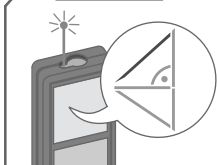

Puntare il laser sul punto superiore.

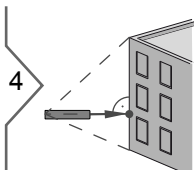

Puntare il laser perpendicolarmente al punto.

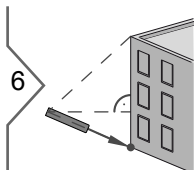

Puntare il laser sul punto inferiore.

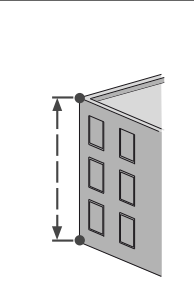



i

Il risultato viene indicato nella riga principale e la distanza misurata sopra a questa. Premendo il tasto di misura per 2 s in questa funzione si attiva automaticamente la misura minima o massima.

**Pitagora (altezza parziale)**

1





2



Puntare il laser sul punto superiore.

3



4

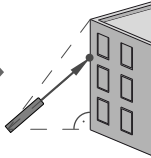

Puntare il laser sul secondo punto.

5





6

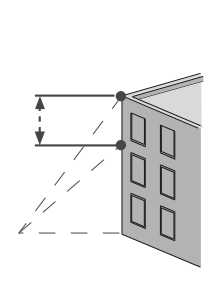

Puntare il laser perpendicolarmente al punto.

7



**i**

Il risultato viene indicato nella riga principale e la distanza misurata sopra a questa. Premendo il tasto di misura per 2 s in questa funzione si attiva automaticamente la misura minima o massima.

## Tracciamento

**1** **4x**

**2** **+** **-**

**3** **DIST**

0.625 m

0.625 m

0.625 m

1.000 m

Impostare il valore.

0.625 m

0.625 m

0.240 m

Mancano 0,240 m per raggiungere la distanza di misura successiva di 0,625 m.

**i** Ad una distanza di 0,1 m dal punto di tracciamento a cui ci si sta avvicinando l'apparecchio emette un beep. La funzione può essere interrotta premendo il tasto CLEAR/OFF.

## Smart Horizontal Mode

**1** **%**

**2**

**3** **DIST**

24.3° —  $\alpha$

0.032 m —  $y$

4.827 m —  $z$

Puntare il laser sul target.

**i** Premere nuovamente il tasto per disattivare la misura orizzontale.

### Tracciamento altezza

**i** Questa funzione visualizza di continuo l'altezza tracciata quando si ruota il dispositivo su un treppiede. Non è necessaria la misura della 2a distanza perché viene misurato automaticamente solo l'angolo.

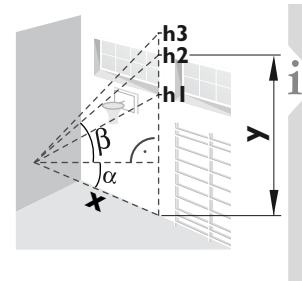
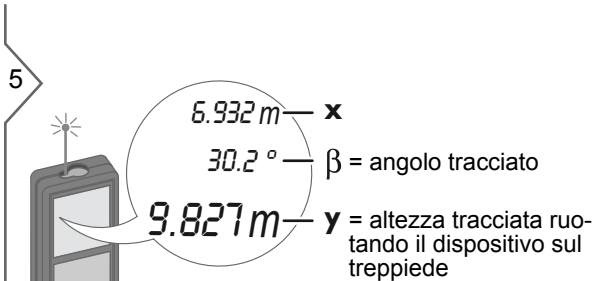
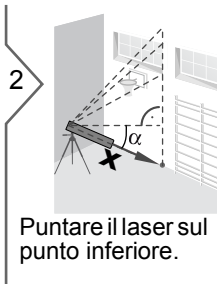
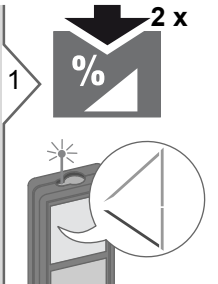

**i** L'altezza tracciata "y" è a 90° rispetto al primo punto mirato "x".



### Livellamento in corso

**i** Questa funzione indica permanentemente l'inclinazione del dispositivo. A partire da un'inclinazione di  $\pm 5^\circ$  il dispositivo inizia ad emettere un segnale acustico rapido. Più si avvicina a  $0^\circ$  più il segnale diventa frequente. Quando raggiunge un'inclinazione di  $\pm 0.3^\circ$  il segnale diventa continuo.

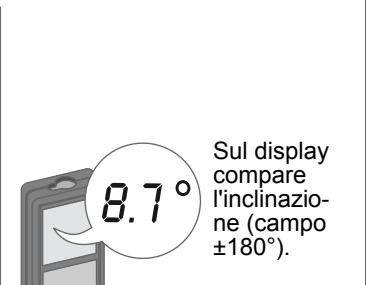
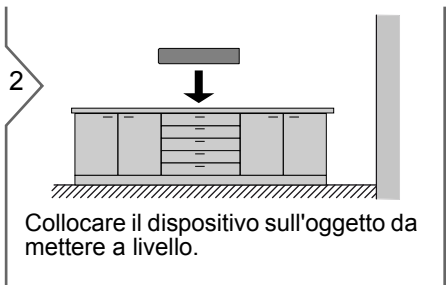
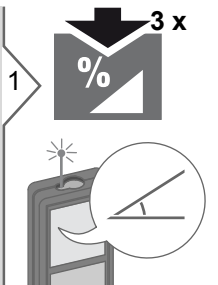

## Funzioni di misura

### Memoria (ultimi 20 valori)

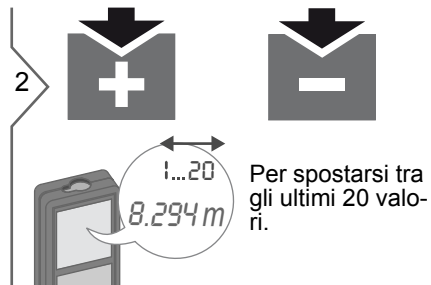
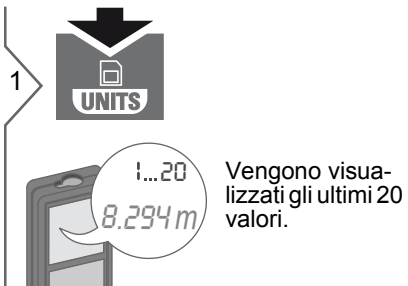

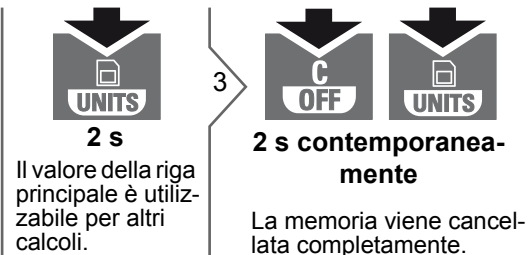

### Cancellazione della memoria





# Calibrazione

## Calibrazione del sensore di inclinazione (calibrazione di inclinazione)

1  **2 s simultaneamente**

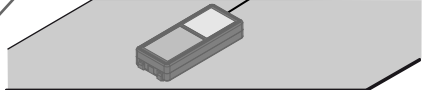
 MEAS 1  
HOR  
CAL

2  Collocare il dispositivo su una superficie perfettamente piana.

3  **DIST**

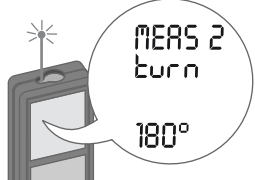
 MEAS 2  
turn  
180°

4  180°  
Ruotare il dispositivo di 180° in senso orizzontale e appoggiarlo nuovamente su una superficie perfettamente piana.

5  **DIST**

 MEAS 3  
VER  
CAL

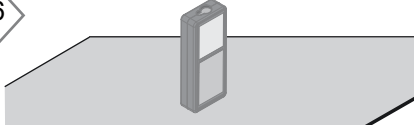
6  Rovesciare il dispositivo e riposizionarlo su una superficie perfettamente piana.

7  **DIST**

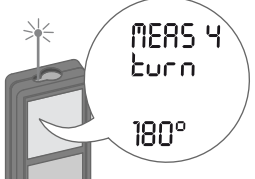
 MEAS 4  
turn  
180°

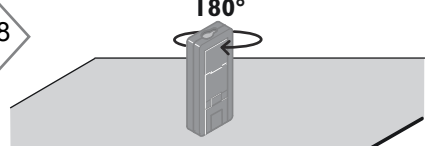
8  180°  
Ruotare il dispositivo di 180° in senso orizzontale e appoggiarlo nuovamente su una superficie perfettamente piana.

9  **DIST**

 OK  
CAL

 Dopo 2 s il dispositivo torna nella modalità normale.

# Dati tecnici

Misura della distanza	
Tolleranza di misura tipica*	± 1,0 mm / 0,04 in ***
Tolleranza di misura massima**	± 2,0 mm / 0,08 in ***
Portata della piastra segnale	100 m / 330 ft
Portata tipica*	80 m / 262 ft
Portata in condizioni sfavorevoli ****	60 m / 197 ft
Unità minima visualizzata	0,1 mm / 1/32 in
Ø punto laser a una distanza di	6 /30 / 60 mm (10 / 50 / 100 m)
Misura dell'inclinazione	
Tolleranza di misura dal raggio laser*****	± 0.2°
Tolleranza di misura dall'alloggiamento*****	± 0.2°
Portata	360°
Informazioni generali	
Classe laser	2
Tipo di laser	635 nm, < 1 mW
Divergenza del raggio	0.16 x 0.6 mrad
Durata impulsi	0.2 x 10 <sup>-9</sup> s - 0.8 x 10 <sup>-9</sup> s
Classe di protezione	IP54 (protetto dalla polvere e dai getti d'acqua)
Spegnimento autom. del laser	Dopo 90 s
Spegnimento autom. dello strumento	Dopo 180 s
Durata delle batterie (2 x AAA)	Fino a 5000 misure
Dimensioni (A x P x L)	125.2 x 58 x 32.6 mm 4.9 x 2.3 x 1.3 in
Peso (con batterie)	154 g / 5.43 oz
Intervallo di temperatura:	
- Stoccaggio	-25 ... 70 °C -13 ... 158 °F
- Funzionamento	-10 ... 50 °C 14 ... 122 °F

\* Per target riflettenti al 100 % (pareti bianche), sfondo scarsamente illuminato, 25 °C

\*\* Per target riflettenti al 10 - 500 %, sfondo fortemente illuminato, da - 10 °C a + 50 °C

\*\*\* Tolleranze valide per una distanza di 0,05 m - 10 m con un livello di certezza del 95%. La tolleranza massima può diminuire a 0,1 mm/m tra 10 m e 30 m e a 0,2 mm/m per le distanze superiori a 30 m

\*\*\*\* Per target riflettenti al 100 %, illuminazione dello sfondo di circa 30.000 lux

\*\*\*\*\* Dopo la calibrazione utente. Deviazione aggiuntiva dall'angolo di +/- 0.01° per grado fino a +/-45° in ciascun quadrante. Riferita alla temperatura ambiente. La deviazione massima aumenta di +/- 0.1° sull'intero campo della temperatura di esercizio.

i Per ottenere risultati indiretti precisi si consiglia di utilizzare un treppiede. Per ottenere misure precise dell'inclinazione evitare l'inclinazione trasversale.

Funzioni	
Misura della distanza	Si
Misura minima/massima	Si
Misura permanente	Si
Tracciamento	Si
Addizione /Sottrazione	Si
Superficie	Si
Volume	Si
Pitagora	2 punti, 3 punti, altezza parziale
Smart Horizontal Mode / Altezza indiretta	Si
Tracciamento altezza	Si
Livellamento	Si
Memoria	20 valori
Beep	Si
Display retroilluminato	Si
Adattatore multifunzione	Si

## Codici dei messaggi

Se dopo aver acceso il dispositivo più volte il messaggio **Error** non scompare, rivolgersi al rivenditore.

Se il messaggio **InFo** compare assieme a un numero premere il tasto Clear e attendersi alle seguenti istruzioni:

N.	Causa	Correzione
156	Inclinazione trasversale superiore a 10°	Tenere lo strumento senza inclinazione trasversale.
162	Errore di calibrazione	Accertarsi che il dispositivo sia collocato su una superficie perfettamente orizzontale e piana. Ripetere la calibrazione. Se l'errore si ripete rivolgersi al proprio rivenditore.
204	Errore di calcolo	Ripetere la misura.
252	Temperatura troppo alta	Far raffreddare il dispositivo.
253	Temperatura troppo bassa	Riscaldare il dispositivo.
255	Il segnale ricevuto è troppo debole, il tempo di misura è troppo lungo	Cambiare la superficie su cui si effettua la misura (ad es. carta bianca).
256	Segnale ricevuto troppo alto	Cambiare la superficie su cui si effettua la misura (ad es. carta bianca).
257	Troppa luce sullo sfondo	Oscurare la superficie su cui si effettua la misura.
258	Misura non compresa nell'intervallo di misura	Correggere l'intervallo di misura.
260	Raggio laser interrotto	Ripetere la misura.

## Cura

- Pulire il dispositivo con un panno umido e morbido.
- Non immergere il dispositivo nell'acqua.
- Non usare detergenti o solventi aggressivi.

## Garanzia

### Europa:

- Garanzia di 30 giorni soddisfatti o rimborsati, senza alcun rischio
- Un anno di assistenza gratuita
- Un anno di garanzia con copertura completa

Per informazioni dettagliate consultare il sito Internet [www.2helpU.com](http://www.2helpU.com).

### Nord America:

- Tre anni di garanzia limitata
- Un anno di assistenza gratuita
- 90 giorni di garanzia soddisfatti o rimborsati

Per informazioni dettagliate consultare il sito Internet [www.dewalt.com](http://www.dewalt.com).

## Istruzioni per la sicurezza

La persona responsabile dello strumento deve accertarsi che tutti gli operatori comprendano e rispettino le istruzioni di sicurezza.

### Ambiti di responsabilità

#### Ambito di responsabilità del produttore dell'attrezzatura originale:

Europa:

DEWALT

D-65510 Idstein, Germany

[www.2helpU.com](http://www.2helpU.com)

[www.dewalt.eu](http://www.dewalt.eu)

Nord America:

DEWALT Industrial Tool Co.

Baltimore, MD21286, USA

Per contattare il servizio di assistenza chiamare 1-800-4-DEWALT.

[www.dewalt.com](http://www.dewalt.com)

L'azienda sopra indicata è responsabile della fornitura dello strumento, compreso il manuale d'uso, in condizioni di totale sicurezza. L'azienda non è responsabile degli accessori di altri produttori.

#### Responsabilità della persona incaricata dello strumento:

- Comprendere le norme di sicurezza dello strumento e le istruzioni del manuale d'uso.
- Conoscere le normative di sicurezza locali relative alla prevenzione degli infortuni.

## Istruzioni per la sicurezza

- Impedire l'accesso al prodotto da parte di persone non autorizzate.

### Uso consentito

- Misura delle distanze
- Misura dell'inclinazione

### Uso non consentito

- Uso dello strumento senza istruzioni
- Uso al di fuori dei limiti stabiliti
- Disattivazione dei sistemi di sicurezza e rimozione delle etichette esplicative e indicatori pericolo
- Apertura dello strumento mediante utensili (cacciaviti, ecc.)
- Esecuzione di modifiche o conversione del prodotto
- Uso di accessori di altre marche senza espressa approvazione
- Abbagliamento intenzionale di terze persone; anche al buio
- Misure di sicurezza insufficienti per il sito di rilievo (es. misure su strade, cantieri, ecc.)
- Maneggiamento intenzionale o con scarsa attenzione su impalcature, su scale, effettuando misure vicino a macchinari in movimento o parti di macchine o impianti privi di protezione
- Puntamento diretto verso il sole

## Pericoli insiti nell'uso

### AVVERTENZA

Se lo strumento è difettoso, è caduto, è stato usato scorrettamente o modificato, verificare che le misure errate della distanza siano corrette. Eseguire periodicamente misure di controllo, in particolare se lo strumento è stato utilizzato in modo eccessivo e prima e dopo delle misure importanti.

### ATTENZIONE

Non eseguire mai riparazioni sul prodotto. Se lo strumento è danneggiato rivolgersi al rivenditore di zona.

### AVVERTENZA

Qualsiasi modifica o variazione non espressamente autorizzata può invalidare il diritto dell'utilizzatore a usare lo strumento.

### Limiti all'uso

-  Consultare il capitolo "Dati tecnici". Lo strumento è adatto all'impiego in ambienti con insediamenti umani permanenti, non può essere utilizzato in ambienti aggressivi o a rischio di esplosione.

## Smaltimento

### ATTENZIONE

Non smaltire le batterie scariche assieme ai rifiuti domestici. Al fine di garantire il rispetto dell'ambiente smaltirle presso i punti di raccolta esistenti secondo quanto previsto dalle disposizioni nazionali o locali.

Non smaltire il prodotto assieme ai rifiuti domestici.

Smaltire il prodotto correttamente, nel rispetto delle normative vigenti nel paese d'uso.



Attenersi alle norme nazionali e locali vigenti in materia.

Le informazioni sul trattamento del prodotto e sulla gestione dei rifiuti possono essere scaricate dalla nostra homepage.

### Compatibilità elettromagnetica (EMC)

### AVVERTENZA

Il dispositivo soddisfa i severi requisiti delle direttive e delle norme in vigore in materia. Non è tuttavia possibile escludere completamente la possibilità che causi disturbi ad altre apparecchiature.

## Classificazione laser

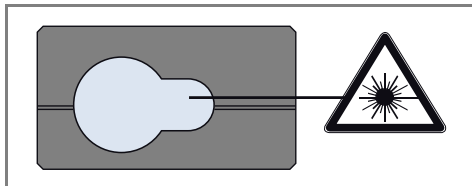

Il dispositivo emette raggi laser visibili che fuoriescono dallo strumento:

Si tratta di un prodotto laser della classe 2 in conformità a:

- IEC60825-1 : 2007 "Sicurezza dei dispositivi laser"

### Prodotti laser della classe 2:

Non fissare il raggio laser né dirigerlo direttamente verso altre persone. Normalmente l'occhio si protegge automaticamente con reazioni fisiche quali il riflesso delle palpebre.

### **⚠ AVVERTENZA**

Guardare direttamente il raggio laser con dispositivi ottici (ad es. binocoli o cannocchiali) può essere pericoloso.

### **⚠ ATTENZIONE**

Guardare il raggio laser può essere pericoloso per la vista.

## Etichette

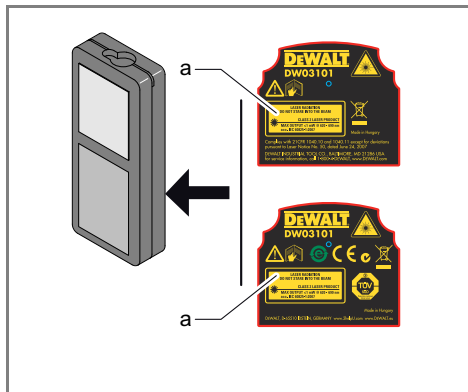

Applicare l'adesivo per il laser (a) scritto nella lingua del proprio paese.

# Índice

- Configuración del instrumento**-----2
  - Introducción -----2
  - Descripción general-----2
  - Display-----3
  - Insertar pilas-----3
- Operaciones** -----4
  - Encender/apagar-----4
  - Borrar-----4
  - Códigos de mensaje -----4
  - Ajuste de la referencia de medición / trípode -----4
  - Extremo multifuncional-----5
  - Ajuste de la unidad de distancia -----5
  - Ajuste de la unidad de inclinación -----5
  - Temporizador (disparo automático)-----5
  - Encender/apagar pitido -----6
  - Encender/apagar iluminación -----6
- Funciones de medición** -----7
  - Medición de distancia simple -----7
  - Medición permanente / mínima-máxima -----7
  - Sumar / Restar -----7
  - Área-----8
  - Volumen-----9
  - Área triangular -----10
  - Pitágoras (2 puntos) -----11
  - Pitágoras (3 puntos) -----11
  - Pitágoras (altura parcial) -----12
  - Replanteo-----13
  - Modo horizontal inteligente-----13
  - Seguimiento de altura -----14
  - Nivelación-----14
  - Memoria (20 últimos resultados)-----15

- Borrar memoria -----15
- Calibración**-----16
  - Calibración del sensor de inclinación  
(calibración de inclinación) -----16
- Datos técnicos** -----17
- Códigos de mensaje** -----18
- Cuidado** -----18
- Garantía** -----18
- Instrucciones de seguridad** -----18
  - Áreas de responsabilidad -----18
  - Empleo correcto -----19
  - Uso impropio -----19
  - Peligros durante el uso-----19
  - Límites de utilización -----19
  - Eliminación -----19
  - Compatibilidad electromagnética (CEM) -----19
  - Declaración de la FCC (aplicable en EE.UU.)-----20
  - Clasificación láser -----20
  - Señalización -----20

### Introducción

 Lea detenidamente las instrucciones de seguridad y el manual de usuario antes de utilizar el producto por primera vez.

 La persona responsable del producto deberá cerciorarse de que todos los usuarios entienden y cumplen estas instrucciones.

Los símbolos utilizados tienen los siguientes significados:

#### **ADVERTENCIA**

Indica una situación de riesgo potencial o de uso inadecuado que, en caso de no evitarse, puede ocasionar lesiones graves o incluso la muerte.

#### **CUIDADO**

Indica una situación de peligro potencial o un empleo no conforme que pueden ocasionar daños personales leves y/o considerables daños materiales, económicos y medioambientales.

 Información importante que debe respetarse en la práctica y que ayuda al usuario a emplear el instrumento de forma eficiente y adecuada técnicamente.

### Descripción general

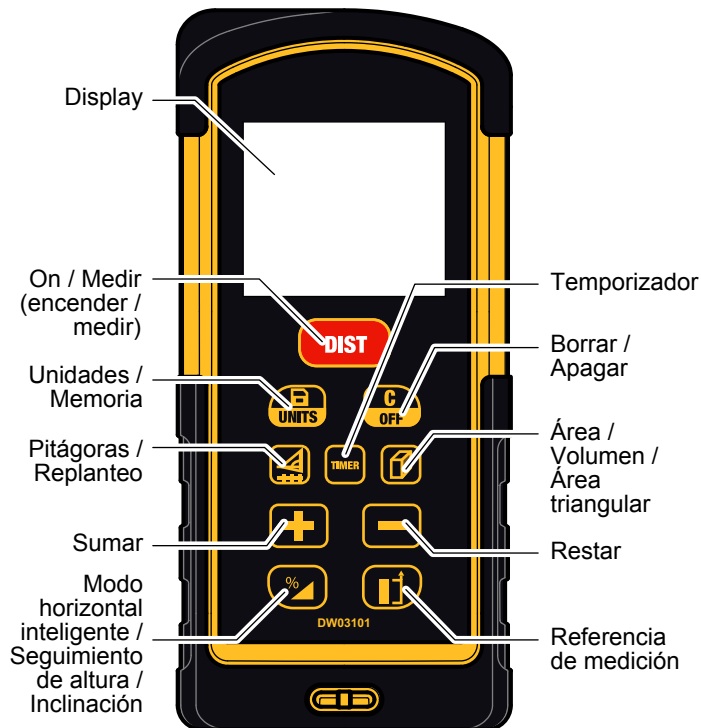

# Configuración del instrumento

## Display

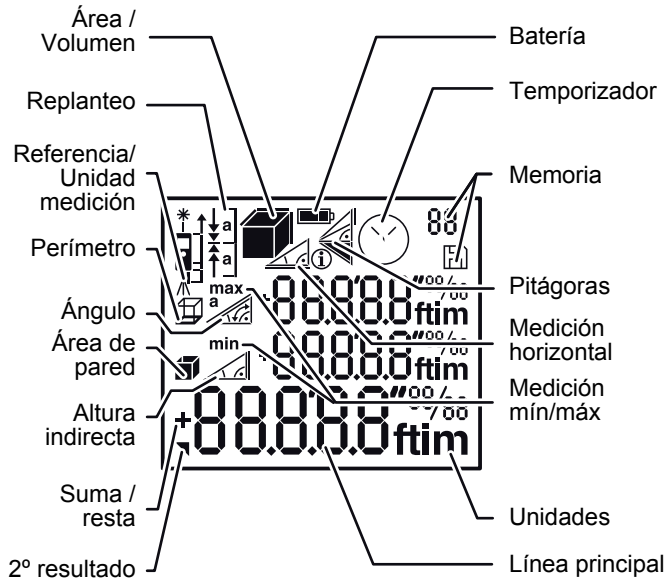

## Insertar pilas

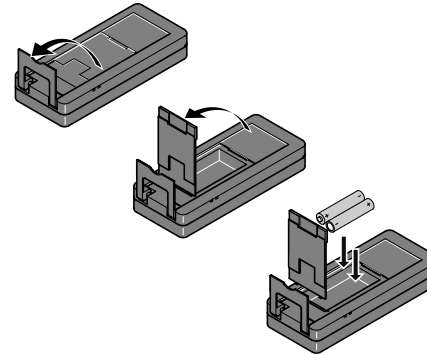

i

Para garantizar un uso fiable, no utilice pilas de carbón-cinc. Cambiar las pilas cuando el símbolo de batería esté intermitente.

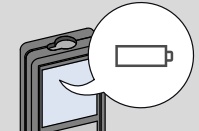

## Encender/apagar



i

Pulse el botón ON durante 2 segundos para iniciar el modo de láser continuo. Si no se pulsa ninguna tecla durante 180 seg, el dispositivo se apaga automáticamente.

## Borrar

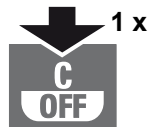

Deshace la última acción.

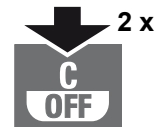

Salte de la función actual, va al modo de funcionamiento por defecto.

## Códigos de mensaje

Si aparece el mensaje "info" con un número, observe las instrucciones de la sección "Códigos de mensaje". Ejemplo:



## Ajuste de la referencia de medición / trípode

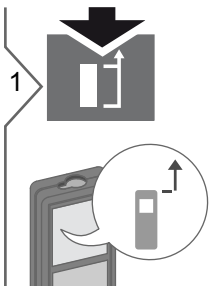

La distancia se mide desde el frontal del dispositivo.

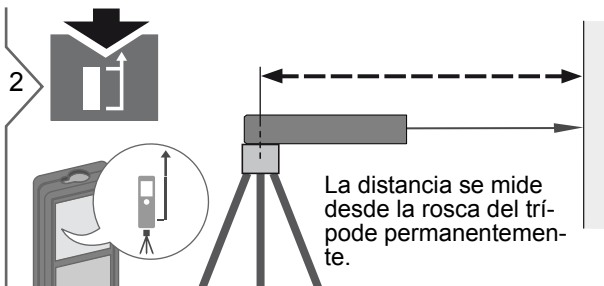

La distancia se mide desde la rosca del trípode permanentemente.

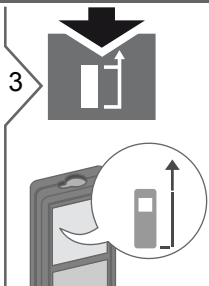

La distancia se mide desde la parte posterior del dispositivo (ajuste estándar).

## Operaciones

### Extremo multifuncional



i

La orientación del extremo se detecta automáticamente y el punto cero se ajusta en conformidad.

### Ajuste de la unidad de distancia



2 seg

Conmutación entre las siguientes unidades:

0.000 m	0.00 ft
0.0000 m	0'00" 1/32
0.00 m	0.00 in
	0 in 1/32

### Ajuste de la unidad de inclinación



2 seg simultáneamente

Conmutación entre las siguientes unidades:

180 °
0.0 %

### Temporizador (disparo automático)

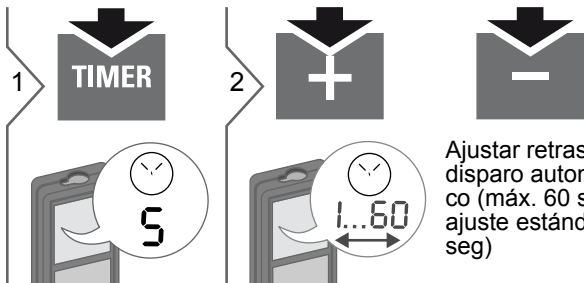

Ajustar retraso del disparo automático (máx. 60 seg, ajuste estándar 5 seg)

i

Una vez que se ha soltado la tecla con el láser activado, los segundos restantes hasta la medición se visualizan en una cuenta atrás. El disparo retardado se recomienda para lograr una puntería precisa, por ejemplo, a largas distancias. Evita la movimiento del dispositivo al pulsar la tecla de medición.

## Operaciones

### Encender/apagar pitido



2 seg simultáneamente

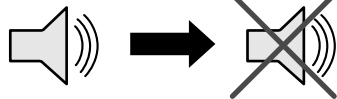

### Encender/apagar iluminación



2 seg simultáneamente

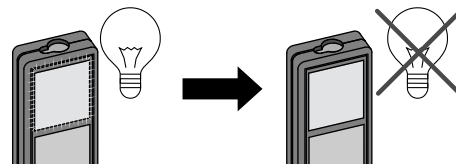

## Funciones de medición

### Medición de distancia simple

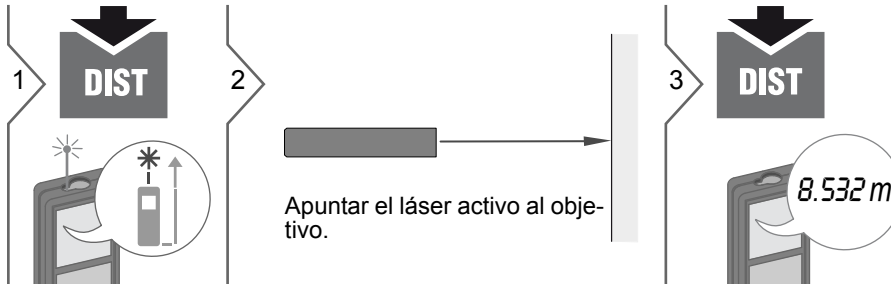

i

Superficies de objetivo: Pueden producirse errores de medición al medir líquidos sin color, cristal, espuma de estireno o superficies semi permeables o al apuntar a superficies de brillo intenso. El tiempo de medición aumenta contra superficies oscuras.

### Medición permanente / mínima-máxima

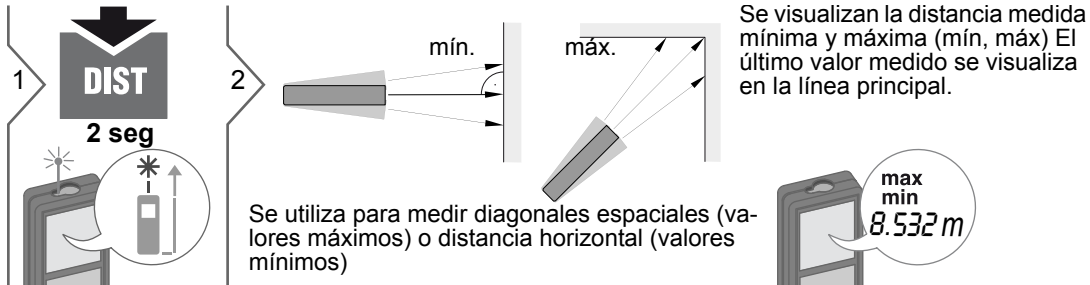

3



Detiene la medición permanente /mínimo-máximo.

### Sumar / Restar

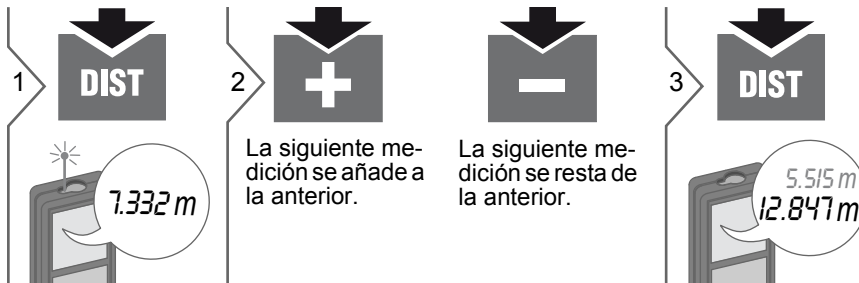

i

El resultado siempre se mostrará en la línea principal y el valor medido encima. Este proceso puede repetirse cuantas veces sea necesario. El mismo proceso puede utilizarse para la suma o resta de áreas y volúmenes.

## Área

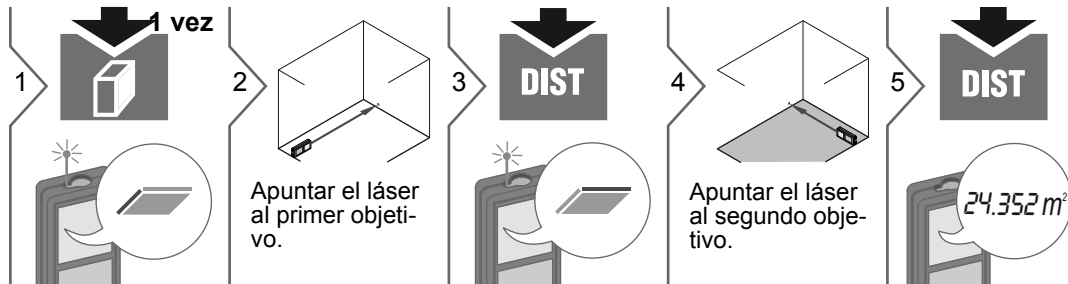

i

El resultado siempre se mostrará en la línea principal y el valor medido encima.

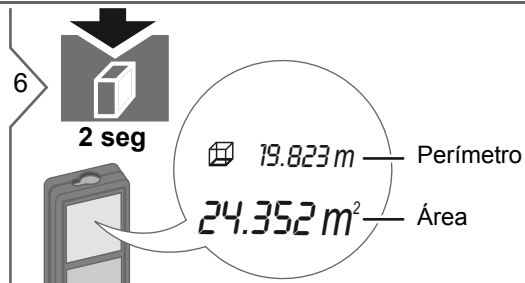

# Funciones de medición

## Volumen

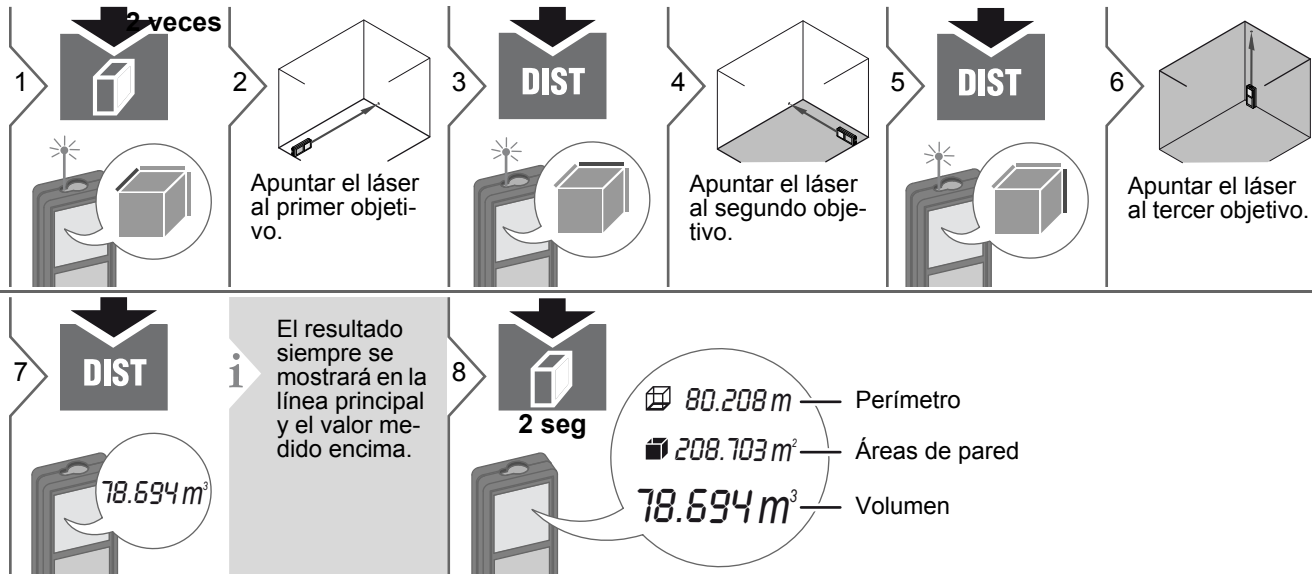

Área triangular

1

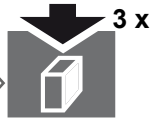
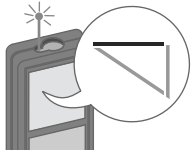

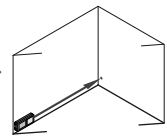

2

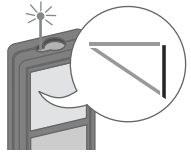

Apuntar el láser al primer objetivo.

3

4

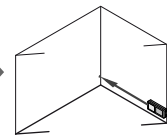

Apuntar el láser al segundo objetivo.

5



6

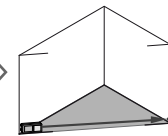





Apuntar el láser al tercer objetivo.

7





8



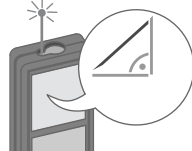

  $40.8^\circ$  — Ángulo incluido por las primeras dos mediciones  
  $33.852\text{ m}$  — Perímetro  
  $24.352\text{ m}^2$  — Área triangular

## Funciones de medición

### Pitágoras (2 puntos)

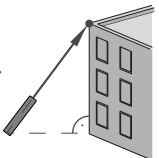
1  

2  Apuntar el láser al punto superior.

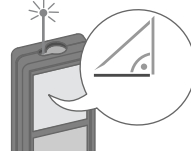
3  

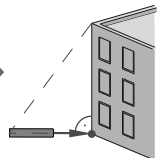
4  Apuntar el láser rectangular al punto inferior.

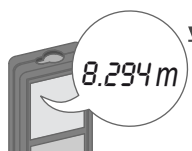
5  

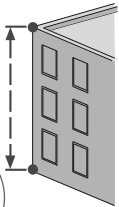
 **i** El resultado siempre se mostrará en la línea principal y el valor medido encima. Pulsando la tecla de medición durante 2 seg en la función se activa automáticamente la medición Mínimo o Máximo.

### Pitágoras (3 puntos)

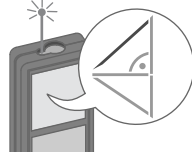
1  

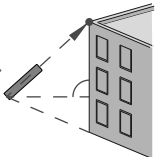
2  Apuntar el láser al punto superior.

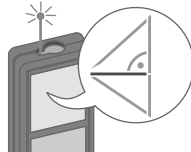
3  

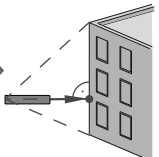
4  Apuntar el láser al punto rectangular.

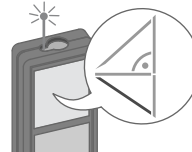
5  

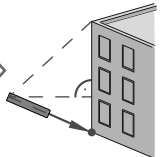
6  Apuntar el láser el punto inferior.

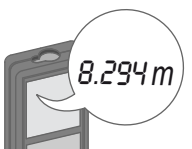
7  

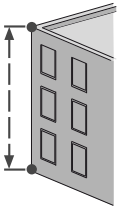
 **i** El resultado siempre se mostrará en la línea principal y el valor medido encima. Pulsando la tecla de medición durante 2 seg en la función se activa automáticamente la medición Mínimo o Máximo.

## Pitágoras (altura parcial)

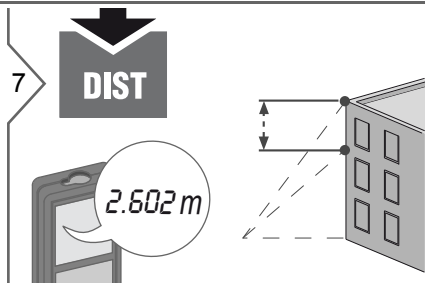



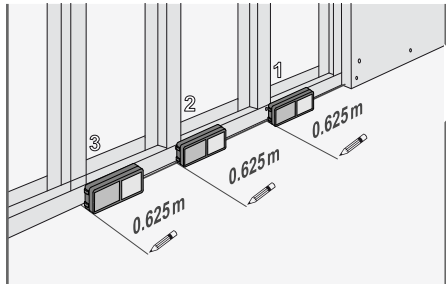

**i**  
El resultado siempre se mostrará en la línea principal y el valor medido encima.  
Pulsando la tecla de medición durante 2 seg en la función se activa automáticamente la medición Mínimo o Máximo.

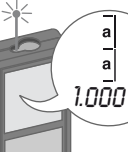
## Replanteo



**1**    $1.000\text{ m}$

**2**   Ajustar valor.   $0.625\text{ m}$

**3**  Aprobar valor e iniciar medición.

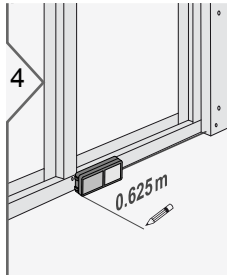
**4**  Mover el dispositivo lentamente a lo largo de la línea de replanteo. Se visualiza la distancia hasta el siguiente punto de replanteo.

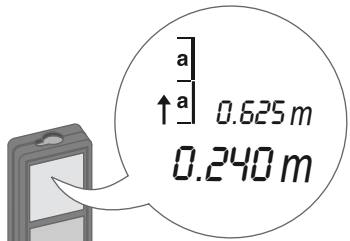
  $0.625\text{ m}$   
 $0.240\text{ m}$



Faltan 0,240 m hasta la siguiente distancia de 0,625 m.

**i** Al acercarse a un punto de replanteo a menos de 0,1 m, el instrumento comienza a pitar. La función puede detenerse pulsando el botón CLEAR/OFF.

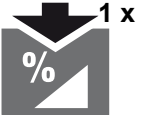
## Modo horizontal inteligente

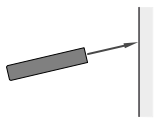
**1**   $1\text{ x}$

**2**  Apuntar el láser al objetivo.

**3**    $4.827\text{ m}$

$24.3^\circ$  —  $\alpha$   
 $0.032\text{ m}$  —  $y$   
 $4.827\text{ m}$  —  $z$

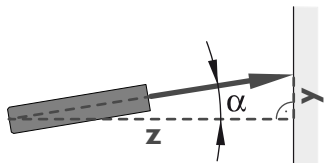
  $\alpha$   
 $z$

(hasta  $360^\circ$  y una inclinación transversal de  $\pm 10^\circ$ )

**i** Pulsar la tecla de nuevo para apagar la medición horizontal.

# Funciones de medición

## Seguimiento de altura

**i** Esta función muestra continuamente el seguimiento de altura si el dispositivo está colocado en un trípode. No se necesita una 2ª medición de distancia puesto que solo se mide el ángulo automáticamente.

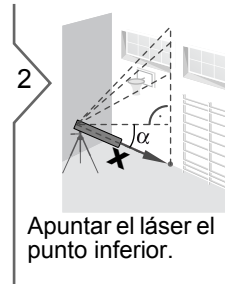
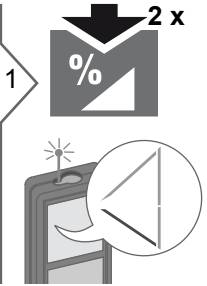

Apuntar el láser el punto inferior.

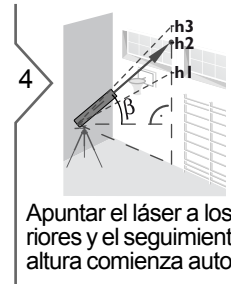

Apuntar el láser a los puntos superiores y el seguimiento de ángulo y altura comienza automáticamente.

**5**

6.932 m — **x**  
 30.2° — **β** = Ángulo de seguimiento  
 9.827 m — **y** = Altura de seguimiento si el dispositivo está colocado en un trípode

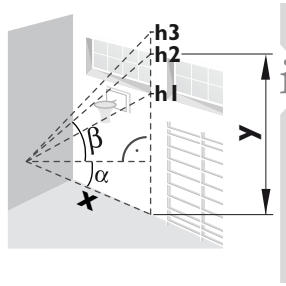

**i** La altura de seguimiento "y" está en 90° respecto al 1er punto apuntado "x".

**6**

Para el seguimiento de altura y se muestra la última medición.

## Nivelación

**i** Esta función muestra continuamente la inclinación del dispositivo. Desde una inclinación del ±5°, el dispositivo comienza a pitar frecuentemente. Cuando se acerca a 0°, más rápido se emite el pitido. Cuando se alcanza una inclinación de ±0.3°, el dispositivo pita continuamente.

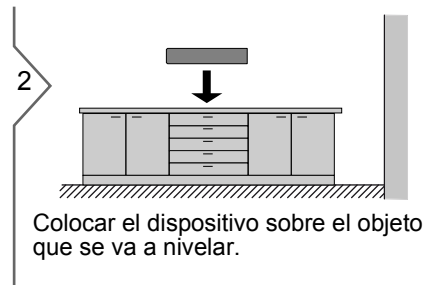
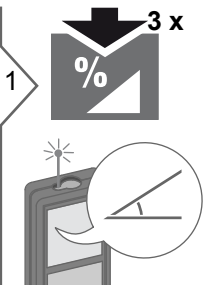

Colocar el dispositivo sobre el objeto que se va a nivelar.

Se visualiza la inclinación (Alcance ±180°).

## Funciones de medición

### Memoria (20 últimos resultados)

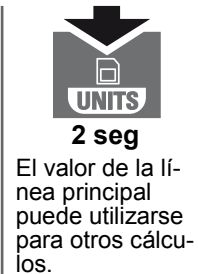
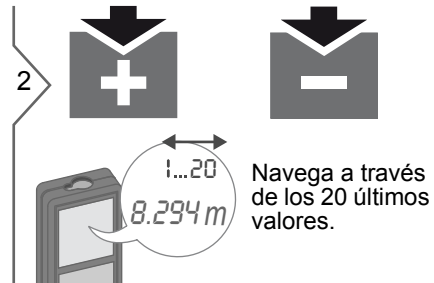
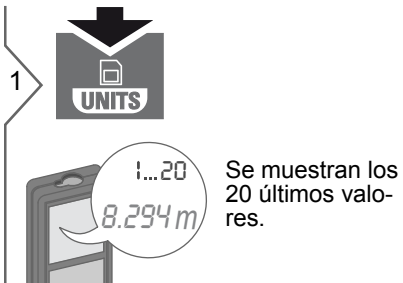

### Borrar memoria

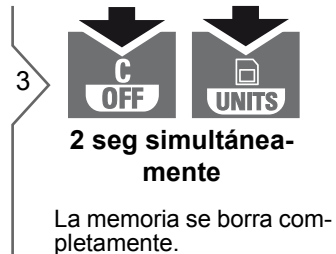

## Calibración del sensor de inclinación (calibración de inclinación)

1  **2 seg simultáneamente**

 MEAS 1 HOR  
CAL

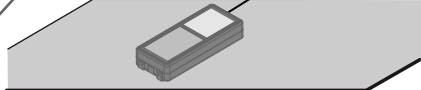
2  Colocar el dispositivo sobre una superficie absolutamente plana.

3  **DIST**

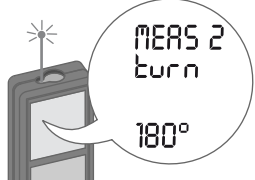
 MEAS 2 turn  
180°

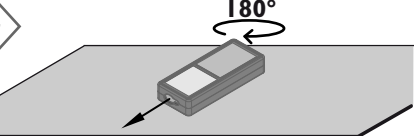
4  180°  
Girar el dispositivo horizontalmente 180° y colóquelo de nuevo sobre una superficie absolutamente plana.

5  **DIST**

 MEAS 3 VER  
CAL

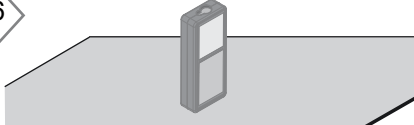
6  Girar el dispositivo boca abajo y colocarlo de nuevo sobre una superficie absolutamente plana.

7  **DIST**

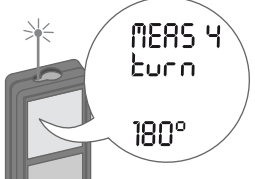
 MEAS 4 turn  
180°

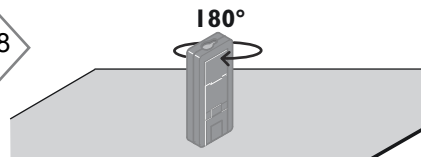
8  180°  
Girar el dispositivo horizontalmente 180° y colóquelo de nuevo sobre una superficie absolutamente plana.

9  **DIST**

 OK  
CAL

 Después de 2 seg el dispositivo vuelve al modo normal.

# Datos técnicos

Medición de distancia	
<b>Tolerancia de medición típica *</b>	± 1.0 mm / 0.04 in ***
<b>Tolerancia de medición máxima**</b>	± 2.0 mm / 0.08 in ***
<b>Alcance de tablilla de puntería</b>	100 m / 330 ft
<b>Alcance típico *</b>	80 m / 7.985,76 cm
<b>Alcance en condición desfavorable ****</b>	60 m / 197 ft
<b>Unidad mínima visualizada</b>	0,1 mm / 1/32 in
<b>Ø punto láser a distancias</b>	6 / 30 / 60 mm (10 / 50 / 100 m)
Medición de inclinación	
<b>Tolerancia de medición respecto al rayo láser*****</b>	± 0.2°
<b>Tolerancia de medición respecto a la carcasa*****</b>	± 0.2°
<b>Rango de medición</b>	360°
General	
<b>Clase de láser</b>	2
<b>Tipo de láser</b>	635 nm, < 1 mW
<b>Divergencia del haz</b>	0,16 x 0,6 mrad
<b>Duración de los impulsos</b>	0.2 x 10 <sup>-9</sup> s - 0.8 x 10 <sup>-9</sup> s
<b>Clase de protección</b>	IP54 (protección contra polvo y agua proyectada)
<b>Desconexión autom. del láser</b>	después de 90 s
<b>Desconexión autom. de energía</b>	después de 180 s
<b>Duración de las pilas (2 x AAA)</b>	hasta 5000 mediciones
<b>Dimensiones (Al x P x An)</b>	125.2 x 58 x 32.6 mm 4.9 x 2.3 x 1.3 in
<b>Peso (con pilas)</b>	154 g / 5.43 oz
<b>Rango de temperaturas:</b>	
- Almacenaje	-25 hasta 70 °C -13 hasta 158 °F
- Funcionamiento	-10 hasta 50 °C 14 hasta 122 °F

\* aplica para el 100 % de reflectividad de objetivo (pared pintada en blanco), baja iluminación de fondo, 25 °C

\*\* aplica para el 10 al 500 % de reflectividad del objetivo, elevada iluminación de fondo, - 10 °C a + 50 °C

\*\*\* Las tolerancias aplican desde 0.05 m a 10 m con un nivel de confianza del 95%. La tolerancia máxima puede bajar a 0,1 mm/m entre 10 m a 30 m y a 0.2 mm/m para distancias por encima de 30 m

\*\*\*\* aplica para 100 % de reflectividad de objetivo, iluminación de fondo de aproximadamente 30.000 lux

\*\*\*\*\* después de calibración por el usuario. Desviación asociada de ángulo adicional de +/- 0,01° por grado hasta +/-45° en cada cuadrante. Aplica a temperatura ambiente. Para todo el rango de temperaturas operativas, la desviación máxima aumenta en +/- 0,1°.

**i** Para resultados indirectos precisos, se recomienda el uso de un trípode. Para realizar mediciones de inclinación precisas, debe evitarse una inclinación transversal.

Funciones	
<b>Medición de distancia</b>	sí
<b>Medición mín/máx</b>	sí
<b>Medición permanente</b>	sí
<b>Replanteo</b>	sí
<b>Suma/Resta</b>	sí
<b>Área</b>	sí
<b>Volumen</b>	sí
<b>Pitágoras</b>	2 puntos, 3 puntos, altura parcial
<b>Modo horizontal inteligente / Altura indirecta</b>	sí
<b>Seguimiento de altura</b>	sí
<b>Nivelación</b>	sí
<b>Memoria</b>	20 visualizaciones
<b>Pitido</b>	sí
<b>Display iluminado</b>	sí
<b>Extremo multifuncional</b>	sí

## Códigos de mensaje

Si el mensaje **Error** no desaparece después de conectar el dispositivo repetidamente, contacte con el distribuidor.

Si aparece el mensaje **InFo** con un número, pulse el botón Clear y tenga en cuenta las siguientes instrucciones:

N.º	Causa	Corrección
156	Inclinación transversal superior a los 10°	Sujetar el instrumento sin ninguna inclinación transversal.
162	Error de calibración	Asegúrese de que el dispositivo está colocado sobre una superficie absolutamente horizontal y lisa. Repetir el procedimiento de calibración. Si el error persiste, contacte con su distribuidor.
204	Error en el cálculo	Repetir la medición.
252	Temperatura demasiado alta	Dejar que el instrumento se enfríe.
253	Temperatura demasiado baja	Calentar el instrumento.
255	Señal de recepción muy débil, tiempo de medición muy largo	Cambiar la superficie de objetivo (p. ej. papel blanco).
256	Señal de recepción demasiado potente	Cambiar la superficie de objetivo (p. ej. papel blanco).
257	Demasiada luz de fondo	Oscurecer el área de objetivo.
258	Medición fuera del rango de medición	Rango correcto.
260	Rayo láser interrumpido	Repetir medición.

## Cuidado

- Limpie el instrumento con un paño suave y húmedo.
- No introduzca nunca el instrumento en agua.
- No utilice nunca agentes o disolventes de limpieza agresivos.

## Garantía

### Europa:

- 30 días de garantía de satisfacción sin riesgo
- Un año de mantenimiento gratis
- Una año de garantía total

Dispone de información detallada en internet en [www.2helpU.com](http://www.2helpU.com).

### Norte América:

- Tres años de garantía limitada
- Un año de mantenimiento gratis
- 90 días de garantía de devolución del dinero

Dispone de información detallada en internet en [www.dewalt.com](http://www.dewalt.com).

## Instrucciones de seguridad

La persona responsable del instrumento deberá cerciorarse de que todos los usuarios entienden y cumplen estas instrucciones.

### Áreas de responsabilidad

#### Responsabilidades del fabricante del equipo original:

Europa:

DEWALT

D-65510 Idstein, Germany

[www.2helpU.com](http://www.2helpU.com)

[www.dewalt.eu](http://www.dewalt.eu)

Norte América:

DEWALT Industrial Tool Co.

Baltimore, MD21286, USA

Teléfono de servicio 1-800-4-DEWALT.

[www.dewalt.com](http://www.dewalt.com)

La compañía mencionada es responsable del suministro del producto, incluyendo el Manual del usuario, en perfectas condiciones. La compañía no se hace responsable de los accesorios de terceros.

#### Ámbito de responsabilidad del encargado del instrumento:

- Entender las instrucciones de seguridad del producto y las instrucciones del Manual del usuario.
- Conocer las normas de seguridad local referidas a la prevención de accidentes
- Evitar siempre el acceso al producto de personal no autorizado.

## Instrucciones de seguridad

### Empleo correcto

- Medición de distancias
- Medición de inclinación

### Uso impropio

- Emplear el producto sin previa instrucción
- Emplear el instrumento fuera de los límites de aplicación
- Anulación de los dispositivos de seguridad y retirada de rótulos indicativos o de advertencia
- Abrir el equipo utilizando herramientas (destornilladores, etc.)
- Modificar o alterar el producto
- Utilizar accesorios de otros fabricantes que no estén expresamente autorizados
- Deslumbrar intencionadamente a terceros, incluso en la oscuridad
- Protección insuficiente del lugar de medición (por ejemplo, durante la medición en carreteras, emplazamientos de construcción, etc.)
- Conducta inapropiada o irresponsable en andamios, escaleras, así como durante mediciones en las proximidades de máquinas en marcha, de elementos de las máquinas y de instalaciones desprotegidas
- Apuntar directamente al sol

### Peligros durante el uso

#### ADVERTENCIA

Pueden producirse mediciones erróneas si se utiliza un instrumento que esté defectuoso o que se haya caído o haya sido objeto de transformaciones no permitidas. Realizar periódicamente mediciones de control.

Especialmente cuando el instrumento ha estado sometido a esfuerzos excesivos, así como antes y después de tareas de medición importantes.

#### CUIDADO

No intente nunca reparar el producto por su cuenta. En caso de presentarse daños, contacte con su distribuidor local.

#### ADVERTENCIA

Los cambios o modificaciones no expresamente aprobados podrían anular la autoridad del usuario para manejar el equipo.

#### Límites de utilización

 Consulte el capítulo "Datos técnicos". El dispositivo está diseñado para uso en áreas permanentemente habitadas. No debe emplearse en entornos con peligro de explosión ni en entornos hostiles.

### Eliminación

#### CUIDADO

Las pilas vacías no deben eliminarse con la basura doméstica. Cuide el medio ambiente y llévelas a los puntos de recogida disponibles de conformidad con las regulaciones nacionales y locales.

No desechar el producto con la basura doméstica.

Desechar el producto correctamente. Cumplir con las normas de desecho específicas del país.

Respetar la normativa específica nacional y local.

La información sobre el tratamiento específico del producto y de gestión de residuos puede descargarse desde la página web.

#### Compatibilidad electromagnética (CEM)

#### ADVERTENCIA

El dispositivo es conforme a los requisitos más estrictos de las normas y regulaciones pertinentes.

Sin embargo, la posibilidad de causar interferencias en otros dispositivos no se puede excluir totalmente.



### Declaración de la FCC (aplicable en EE.UU.)

Este equipo ha sido probado y ha demostrado cumplir con los límites establecidos para los dispositivos digitales de Clase B, según la parte 15 de las normas de la FCC. Estos límites están diseñados para proporcionar una protección razonable contra las interferencias perjudiciales en una instalación residencial. Este equipo genera, utiliza y puede irradiar energía de radiofrecuencia y, si no se instala y utiliza de acuerdo con las instrucciones, puede causar interferencias perjudiciales en las comunicaciones por radio.

No obstante, no hay garantía de que no se produzcan interferencias en una instalación particular. Si este equipo causa interferencias perjudiciales en la recepción de radio o televisión, lo que puede determinarse encendiéndolo y apagándolo, se recomienda al usuario que intente corregir la interferencia mediante una o más de las siguientes medidas:

- Reorientar o reubicar la antena receptora.
- Aumentar la separación entre el equipo y el receptor.
- Conectar el equipo a una toma de corriente en un circuito diferente de aquel al que está conectado el receptor.
- Consulte al distribuidor o a un técnico experto en radio/TV para obtener ayuda.

### Clasificación láser

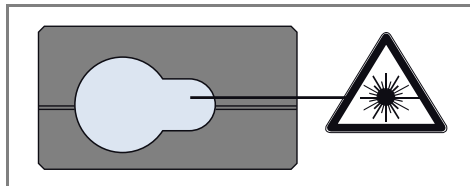

El dispositivo genera rayos láser visibles que se emiten desde el instrumento:

El producto corresponde a la Clase de láser 2 con:

- IEC60825-1 : 2007 "Seguridad de los productos láser"

### Productos de Clase de láser 2:

Absténgase de mirar directamente al rayo láser y no lo dirija a otras personas. La protección de los ojos queda garantizada mediante reflejos naturales como es el de desviar la vista del rayo o cerrar los ojos.

### ⚠️ ADVERTENCIA

Puede ser peligroso mirar directamente al rayo con medios ópticos auxiliares (p. ej. prismáticos, telescopios).

### ⚠️ CUIDADO

Mirar directamente al rayo láser puede ser peligroso para los ojos.

### Señalización

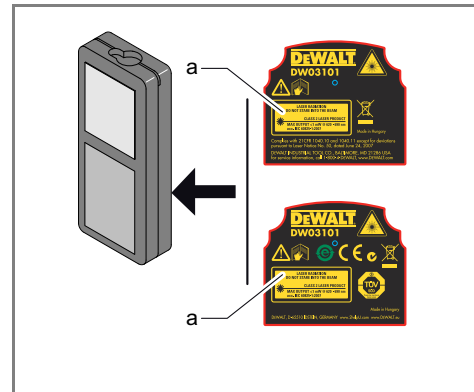

Pegue la etiqueta de láser (a) en el idioma de su país.

# Índice

<b>Configuração do instrumento</b> .....	<b>2</b>
Introdução .....	2
Apresentação geral .....	2
Visor .....	3
Instalação das pilhas .....	3
<b>Operações</b> .....	<b>4</b>
Ligar e Desligar .....	4
Apagar .....	4
Códigos de mensagens .....	4
Ajustamento da referência de medição / tripé .....	4
Tampa multifunções .....	5
Configuração das unidades de distância .....	5
Configuração da inclinação do instrumento .....	5
Temporizador (disparo automático) .....	5
Aviso acústico ON/OFF .....	6
Botão de iluminação ON/OFF .....	6
<b>Funções de medição</b> .....	<b>7</b>
Medição de distância individual .....	7
Medição permanente / mínima/máxima .....	7
Adição / Subtracção .....	7
Área .....	8
Volume .....	9
Área de triângulo .....	10
Triângulo rectângulo (2 vértices) .....	11
Triângulo rectângulo (3 vértices) .....	11
triângulo rectângulo (altura parcial) .....	12
Implantação .....	13
Modo Horizontal Inteligente .....	13
Medição contínua da altura .....	14
Nivelamento .....	14
Memória (últimos 20 resultados) .....	15

Apagamento da memória .....	15
<b>Calibração</b> .....	<b>16</b>
Calibração do sensor de inclinação (Calibração da inclinação) .....	16
<b>Características técnicas</b> .....	<b>17</b>
<b>Códigos de mensagens</b> .....	<b>18</b>
<b>Cuidados e manutenção</b> .....	<b>18</b>
<b>Garantia</b> .....	<b>18</b>
<b>Instruções de segurança</b> .....	<b>18</b>
Áreas de responsabilidade .....	18
Utilização correcta .....	19
Utilização incorrecta .....	19
Riscos da utilização .....	19
Limites da utilização do instrumento .....	19
Eliminação final .....	19
Compatibilidade Electromagnética (EMC) .....	19
Classificação do laser .....	20
Marcação do instrumento .....	20

### Introdução

 As instruções de segurança e o manual de operação devem ser lidos atentamente antes de o instrumento ser utilizado pela primeira vez.

 A pessoa responsável pelo instrumento deve verificar se todos os utilizadores compreendem claramente estas instruções e controlar o seu estrito cumprimento.

Os símbolos utilizados neste manual têm os seguintes significados:

### ATENÇÃO

Indicação de uma situação potencialmente perigosa ou de uma utilização não recomendada que, a não ser evitada, pode provocar a morte ou lesões corporais graves.

### AVISO

Indicação de uma situação potencialmente perigosa ou de uma utilização não recomendada que, a não ser evitada, pode provocar lesões corporais ligeiras e/ou danos materiais, financeiros ou ambientais significativos.

 Informações importantes que devem ser observadas, para o instrumento ser utilizado de modo tecnicamente correcto e eficiente.

### Apresentação geral

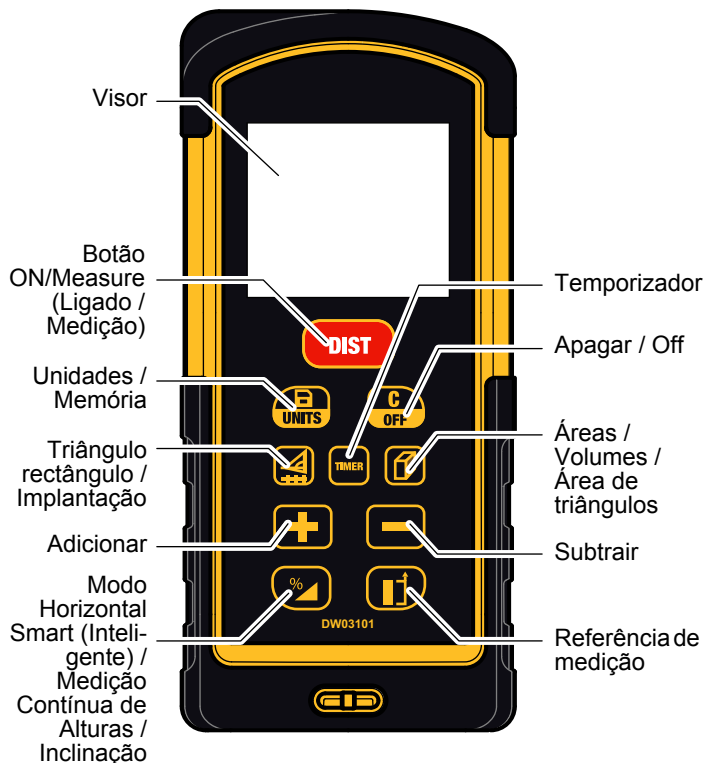

## Visor

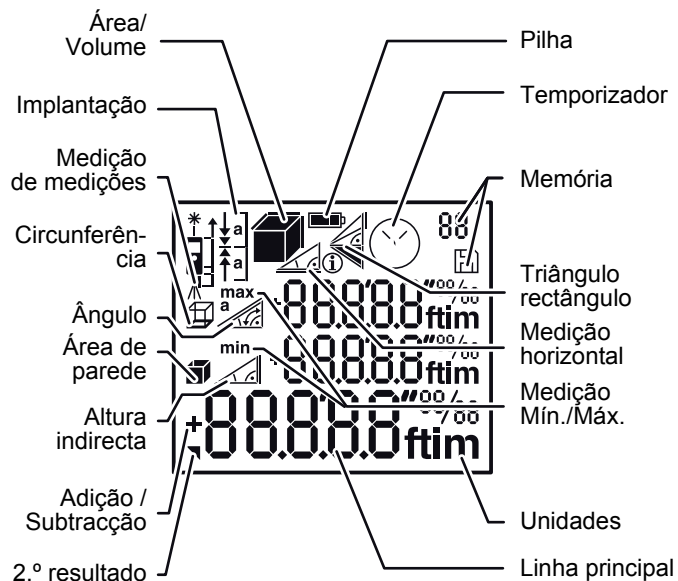

## Instalação das pilhas

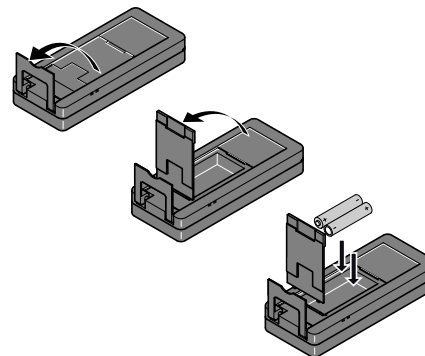

i

Para uma utilização fiável do instrumento, não utilizar pilhas de zinco-carbono. Substituir as pilhas, quando o símbolo da pilha começar a piscar.

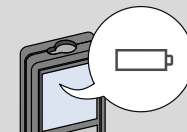

## Ligar e Desligar



O instrumento é desligado.

i

Premir o botão ON durante 2 s, para iniciar o modo de laser contínuo. Se não for premido nenhum botão durante 180 s, o instrumento é desligado automaticamente.

## Apagar

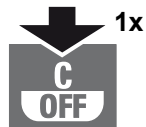

Desfazer a última acção.

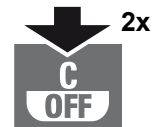

Abandonar a função actual e ir para o modo de operação normal.

## Códigos de mensagens

Se o símbolo "InFo" for apresentado com um número, seguir as instruções do parágrafo "Códigos de mensagens". Exemplo:



## Ajustamento da referência de medição / tripé

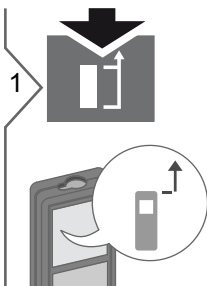

A distância é medida a partir da face dianteira do instrumento.

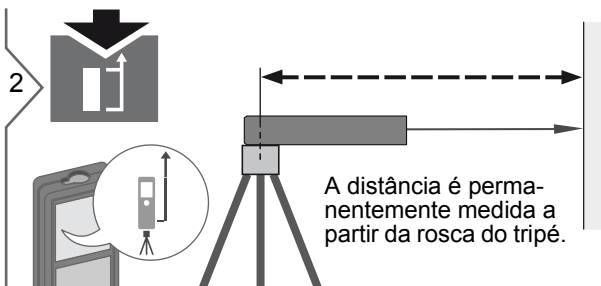

A distância é permanentemente medida a partir da rosca do tripé.

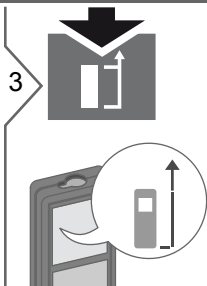

A distância é medida a partir da face traseira do instrumento (configuração normal).

## Operações

### Tampa multifunções

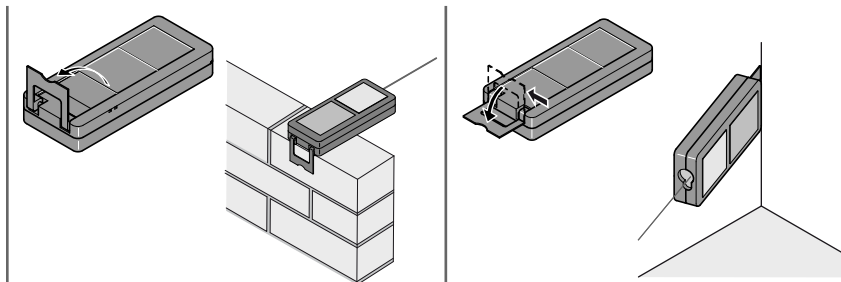

**i** A orientação da tampa multifunções é detectada automaticamente e o ponto zero é ajustado em conformidade.

### Configuração das unidades de distância



2 s

Selecção entre as unidades seguintes:

0.000 m	0.00 ft
0.0000 m	0'00" 1/32
0.00 m	0.00 in
	0 in 1/32

### Configuração da inclinação do instrumento



2 s, ao mesmo tempo

Selecção entre as unidades seguintes:

180 °
0.0 %

### Temporizador (disparo automático)

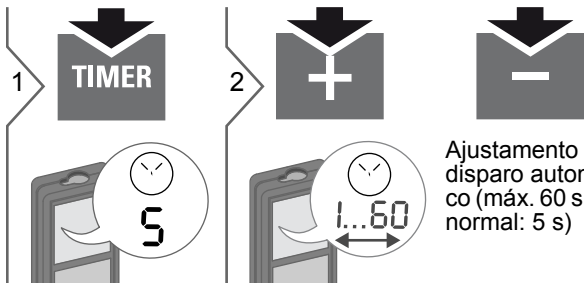

Ajustamento do disparo automático (máx. 60 s; valor normal: 5 s)

**i** Após a libertação da tecla com o laser activado, são apresentados no visor, em ordem decrescente, os segundos remanescentes até ao disparo da medição (por exemplo, 59, 58, 57...). O disparo temporizado é recomendado para apontamentos de precisão, por exemplo em distâncias longas. O sistema impede a vibração do instrumento aquando do accionamento da tecla de medição.

# Operações

## Aviso acústico ON/OFF



2 s, ao mesmo tempo

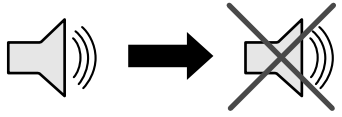

## Botão de iluminação ON/OFF



2 s, ao mesmo tempo

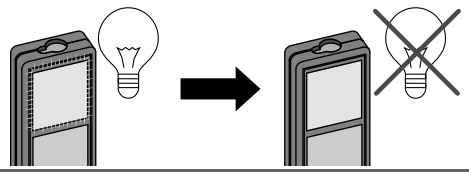

## Funções de medição

### Medição de distância individual

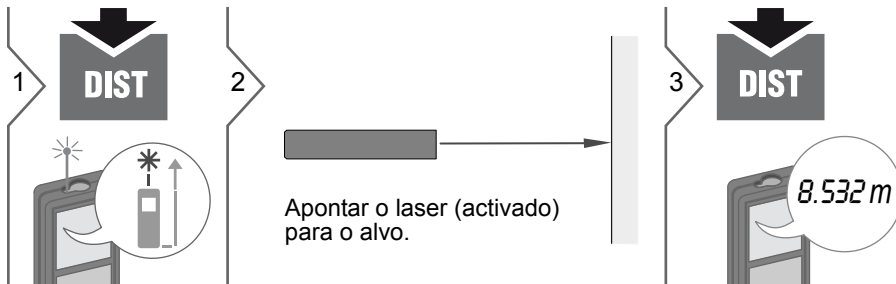

i

Superfícies do alvo: Podem ocorrer erros de medição, quando o laser é apontado para líquidos incolores, vidro, poliestireno expandido ou superfícies semi-permeáveis ou outras superfícies com elevado brilho. Com superfícies escuras, o tempo de medição aumenta.

### Medição permanente / mínima/máxima

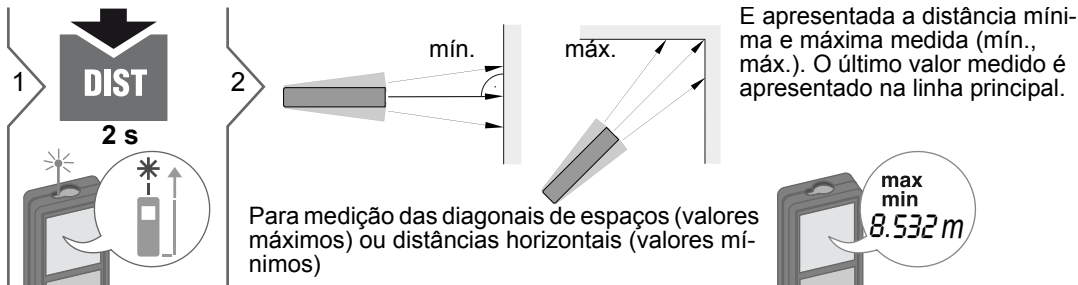

3



Paragem da medição permanente / mínima-máxima.

### Adição / Subtracção

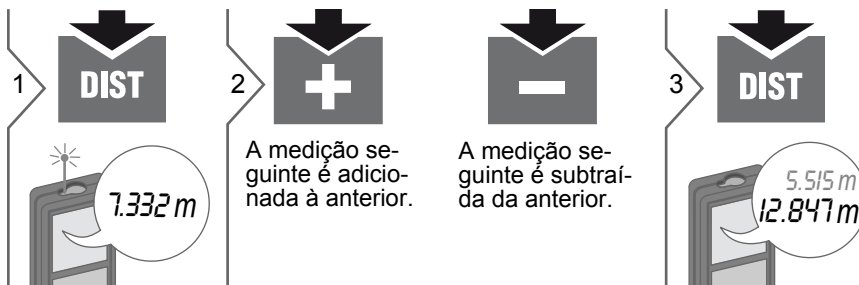

i

O resultado é apresentado na linha principal e o valor medido acima dele. O processo pode ser repetido conforme necessário. O mesmo processo pode ser usado para adicionar ou subtrair áreas ou volumes.

# Funções de medição

## Área

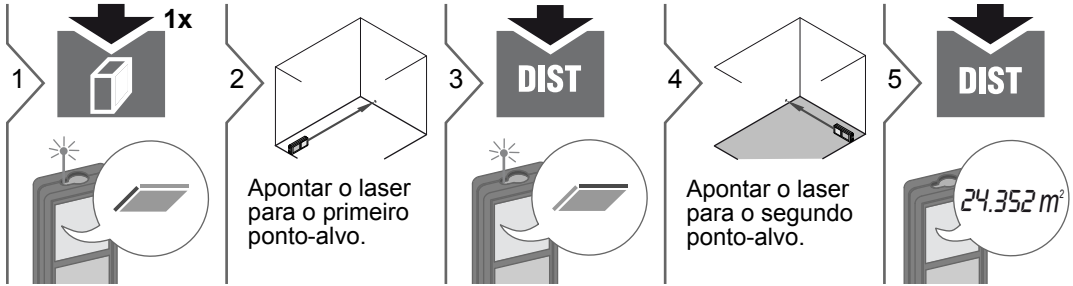

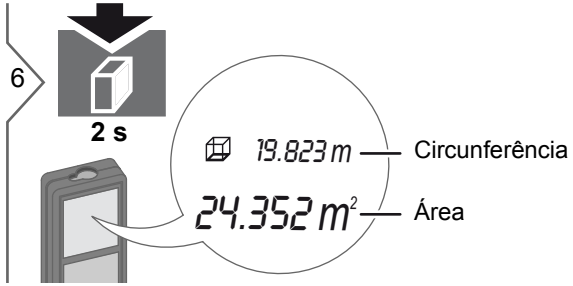

**i** O resultado é apresentado na linha principal e o valor medido acima dele.





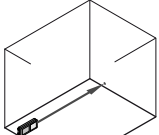

# Funções de medição

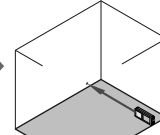

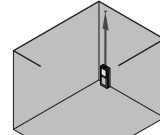

## Volume

1   2 Apontar o laser para o primeiro ponto-alvo.

3   4 Apontar o laser para o segundo ponto-alvo.

5   6 Apontar o laser para o terceiro ponto-alvo.

7    O resultado é apresentado na linha principal e o valor medido acima dele.

8    80.208 m — Circunferência  
 208.703 m<sup>2</sup> — Área de parede  
 78.694 m<sup>3</sup> — Volume

Área de triângulo

1

2

Apontar o laser para o primeiro ponto-alvo.

3

4

Apontar o laser para o segundo ponto-alvo.

5

6

Apontar o laser para o terceiro ponto-alvo.



7

8

40.8 ° — Ângulo incluído pelas duas primeiras medições  
 33.852 m — Circunferência  
 24.352 m<sup>2</sup> — Área de triângulo

## Funções de medição

### Triângulo rectângulo (2 vértices)

1  

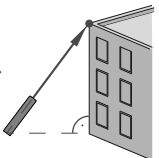
2  Apontar o laser para o vértice superior.

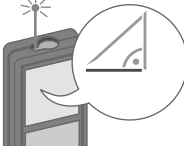

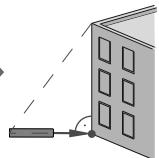
3  

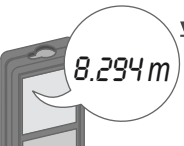
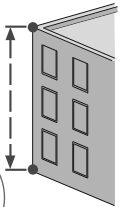
4  Apontar o laser perpendicularmente para o segundo vértice.

5   

**i** O resultado é apresentado na linha principal e o valor medido em cima. Premir o botão de medição durante 2 s durante a função, para activar automaticamente a medição Mínima e Máxima.

### Triângulo rectângulo (3 vértices)

1  

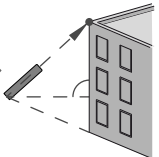

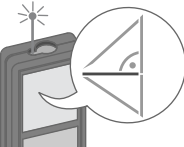
2  Apontar o laser para o vértice superior.

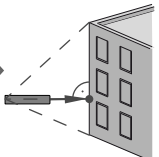
3  

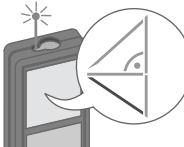
4  Apontar o laser perpendicularmente ao vértice.

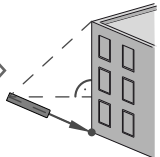
5  

6  Apontar o laser para o vértice inferior.

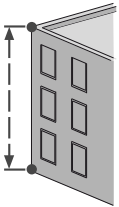
7   

**i** O resultado é apresentado na linha principal e o valor medido em cima. Premir o botão de medição durante 2 s durante a função, para activar automaticamente a medição Mínima e Máxima.

## Funções de medição

### triângulo rectângulo (altura parcial)

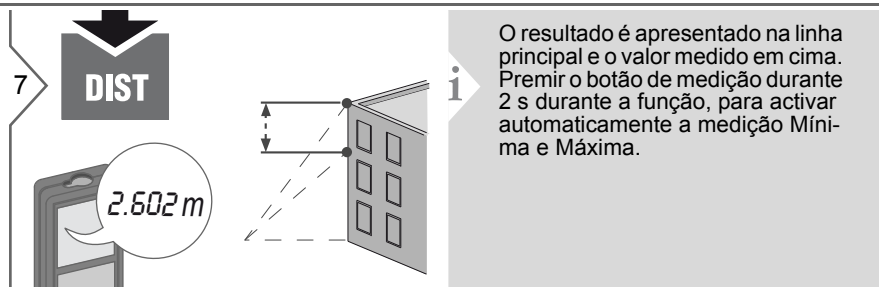

## Funções de medição

### Implantação

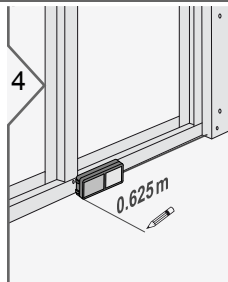
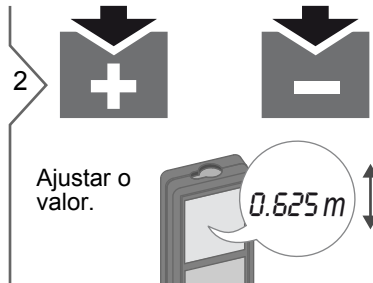
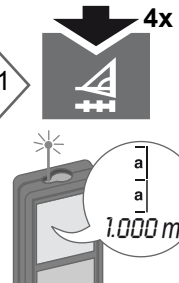
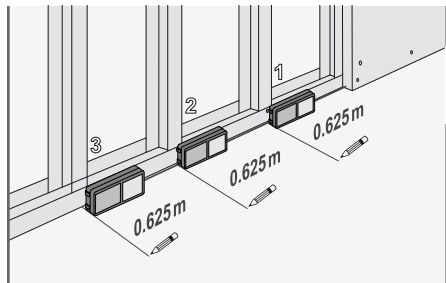

Mover lentamente o instrumento ao longo da linha de implantação. É apresentada a distância até ao ponto de implantação seguinte.

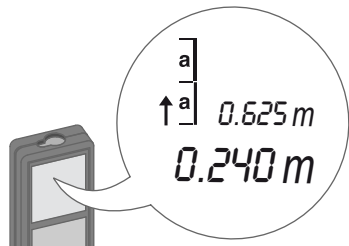

O valor 0.240 m é corrigido para a distância 0.625 m seguinte.

**i** Quando o instrumento se aproxima a menos de 0,1 m de um ponto de implantação, é emitido um aviso acústico. Para parar a função, premir o botão CLEAR/OFF.

### Modo Horizontal Inteligente

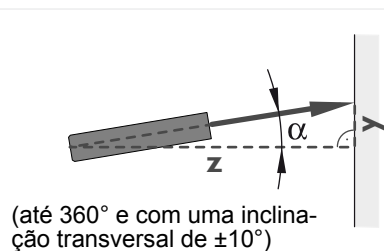
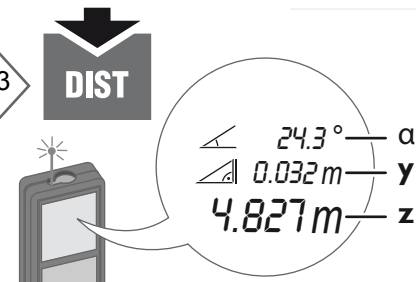
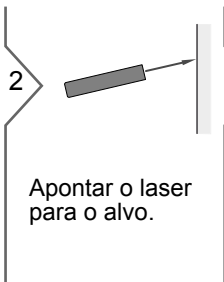
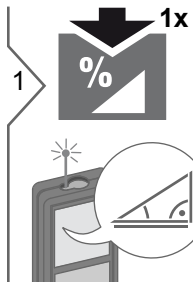

**i** Premir novamente a tecla para desligar a medição horizontal.

(até 360° e com uma inclinação transversal de  $\pm 10^\circ$ )

## Funções de medição

### Medição contínua da altura

Esta função permite medir (e visualizar) continuamente a altura quando o instrumento é rodado num tripé. Não é necessária a medição da 2.ª distância, porque o ângulo é medido automaticamente.

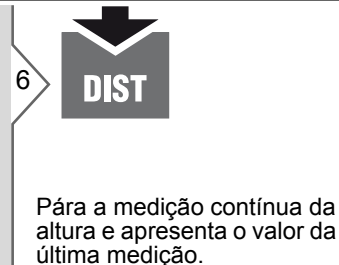
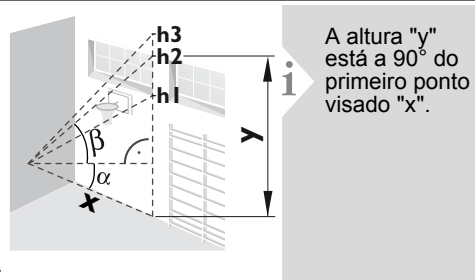
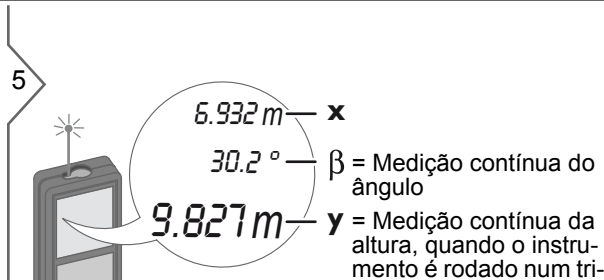
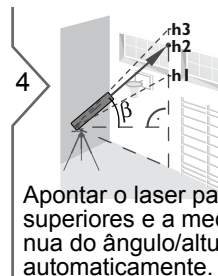
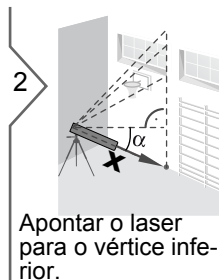
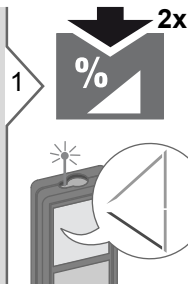

### Nivelamento

Esta função indica continuamente a inclinação do instrumento. A partir de uma inclinação de  $\pm 5^\circ$ , o instrumento emite bips frequentes. Quanto mais a inclinação se aproxima de  $0^\circ$ , mais rápidos são os bips. Quando é atingida uma inclinação de  $\pm 0.3^\circ$ , o instrumento emite um bip contínuo.

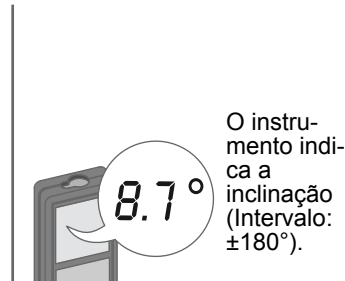
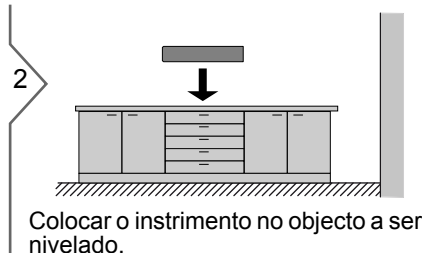
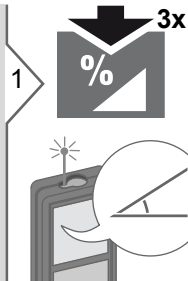

## Funções de medição

### Memória (últimos 20 resultados)

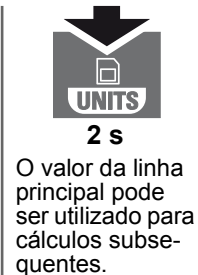
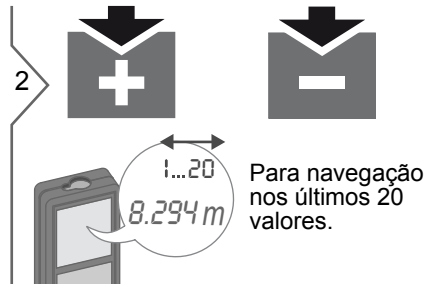
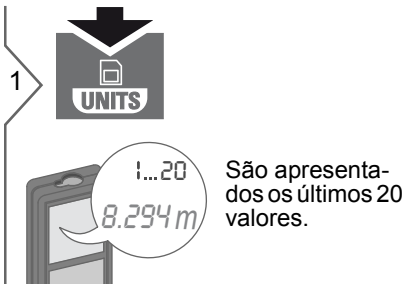

### Apagamento da memória



# Calibração

## Calibração do sensor de inclinação (Calibração da inclinação)

1



2 s, ao mesmo tempo



2

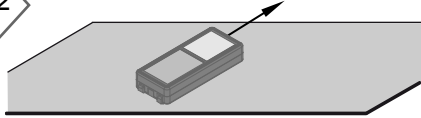

Colocar o instrumento numa superfície completamente horizontal.

3



4

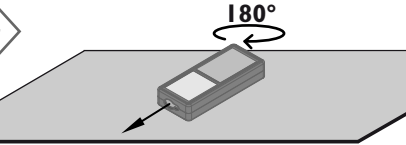

Rodar horizontalmente o instrumento 180° e colocá-lo novamente numa superfície totalmente horizontal.

5



6

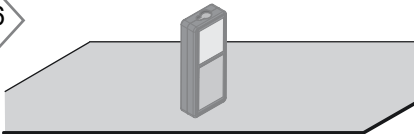

Rodar horizontalmente para baixo e colocá-lo novamente numa superfície totalmente horizontal.

7



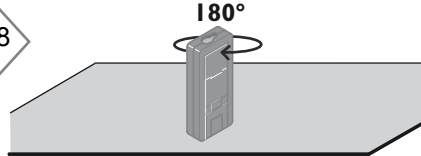

8



Rodar horizontalmente o instrumento 180° e colocá-lo novamente numa superfície totalmente horizontal.

9

**i** Após 2 s, o dispositivo regressa ao modo normal.

Medição de distâncias	
<b>Tolerância da medição (típica)*</b>	± 1.0 mm / 0.04 in ***
<b>Tolerância da medição (máxima)**</b>	± 2.0 mm / 0.08 in ***
<b>Alcance da placa-alvo</b>	100 m / 330 ft
<b>Alcance típico*</b>	80 m / 262 ft
<b>Alcance em condições desfavoráveis ****</b>	60 m / 197 ft
<b>Menor unidade visualizável</b>	0,1 mm / 1/32 in
<b>Ø do ponto de laser às distâncias</b>	6 / 30 / 60 mm (10 / 50 / 100 m)
Medição de inclinações	
<b>Tolerância da medição relativamente ao feixe de laser*****</b>	± 0,2°
<b>Tolerância da medição relativamente ao invólucro*****</b>	± 0,2°
<b>Alcance</b>	360°
Generalidades	
<b>Classe de laser</b>	2
<b>Tipo de laser</b>	635 nm, < 1 mW
<b>Divergência do feixe</b>	0,16 x 0,6 mrad
<b>Duração do impulso</b>	0,2 x 10 <sup>-9</sup> s - 0,8 x 10 <sup>-9</sup> s
<b>Classe de protecção</b>	IP54 (protecção contra o ingresso de poeiras e salpicos de água)
<b>Desligação automática do laser</b>	após 90 s
<b>Desligação automática do instrumento</b>	após 180 s
<b>Duração das pilhas (2 x AAA)</b>	até 5000 medições
<b>Dimensões (A x P x L)</b>	125,2 x 58 x 32,6 mm 4,9 x 2,3 x 1,3 in
<b>Peso (com pilhas)</b>	154 g / 5.43 oz
<b>Gama de temperaturas:</b>	
- Armazenamento	-25 a 70 °C -13 a 158 °F
- Operação	-10 a 50 °C 14 a 122 °F

\* aplicável a 100% de reflectividade do alvo (parede branca), iluminação de fundo reduzida, 25 °C

\*\* aplicável a 10 a 500 % de reflectividade do alvo, iluminação de fundo mais elevada, -10 a +50 °C

\*\*\* As tolerâncias são aplicáveis a 0,05 a 10 m com um nível de confiança de 95%. A tolerância máxima pode deteriorar-se até 0,1 mm/m entre 10 e 30 m e até 0,2 mm/m para distâncias superiores a 30 m

\*\*\*\* aplicável a alvos com 100% de reflectividade e iluminação de fundo de cerca de 30 000 lux

\*\*\*\*\* após calibração efectuada pelo utilizador. Desvio adicional angular de +/-0,01° por grau, até +/-45° em cada quadrante. Aplicável a temperatura ambiente. No caso da totalidade da temperatura de funcionamento, o desvio máximo aumenta +/-0,1°.

- i Para resultados indirectos rigorosos, é recomendável a utilização de um tripé. Para medições de inclinação rigorosas, devem ser evitadas inclinações transversais.

Funções	
<b>Medição de distâncias</b>	sim
<b>Medição Min./Máx.</b>	sim
<b>Medição permanente</b>	sim
<b>Implantação</b>	sim
<b>Adição/Subtracção</b>	sim
<b>Área</b>	sim
<b>Volume</b>	sim
<b>Triângulo rectângulo</b>	2 pontos, 3 pontos, altura parcial
<b>Modo Horizontal Inteligente / Altura indirecta</b>	sim
<b>Medição contínua da altura</b>	sim
<b>Nivelamento</b>	sim
<b>Memória</b>	20 valores
<b>Bip</b>	sim
<b>Visor iluminado</b>	sim
<b>Tampa multifunções</b>	sim

## Códigos de mensagens

Contactar o Distribuidor, se a mensagem **Error** não desaparecer após a desligação e ligação do instrumento diversas vezes. Se a mensagem **InFo** for apresentada com um número, premir o botão Clear (Apagar) e seguir as instruções seguintes:

N.º	Causa	Correcção
156	Inclinação transversal superior a 10°	Segurar no instrumento sem qualquer inclinação transversal.
162	Erro de calibração	O instrumento deve estar colocado numa superfície lisa e totalmente horizontal. Repetir o procedimento de calibração. Se o erro persistir, contactar o Distribuidor.
204	Erro de cálculo	Efectuar novamente a medição.
252	Temperatura demasiado elevada	Deixar arrefecer o instrumento.
253	Temperatura demasiado reduzida	Aquecer o instrumento.
255	Sinal recebido demasiado fraco; a medição demora demasiado tempo	Substituir a superfície do alvo (por exemplo, com papel branco).
256	Sinal recebido demasiado intenso	Substituir a superfície do alvo (por exemplo, com papel branco).
257	Luz de fundo demasiado intensa	Sombrear a área do alvo.
258	Medição fora do alcance da medição	Corrigir o alcance da medição.
260	Interrupção do raio laser	Repetir a medição.

## Cuidados e manutenção

- Limpar o instrumento com um pano macio e húmido.
- Não mergulhar o instrumento em líquidos de qualquer natureza.
- Não limpar o instrumento com produtos de limpeza agressivos ou abrasivos.

## Garantia

### Europa:

- Garantia de satisfação (30 dias, sem riscos)
- Um ano de serviço grátis
- Um ano de garantia total

Para mais informações, visitar o endereço: [www.2helpU.com](http://www.2helpU.com).

### América do Norte:

- Três anos de garantia limitada
- Um ano de serviço grátis
- Garantia de 90 dias (com devolução do montante da compra)

Para mais informações, visitar o endereço: [www.dewalt.com](http://www.dewalt.com).

## Instruções de segurança

A pessoa responsável pelo instrumento deve verificar se todos os utilizadores compreendem claramente estas instruções e o seu estrito cumprimento.

## Áreas de responsabilidade

### Responsabilidades do fabricante de equipamento original :

Europa:

DEWALT

D-65510 Idstein, Germany

[www.2helpU.com](http://www.2helpU.com)

[www.dewalt.eu](http://www.dewalt.eu)

América do Norte:

DEWALT Industrial Tool Co.

Baltimore, MD21286, USA

Para serviços de assistência, contactar pelo telefone (nos Estados Unidos): +1-800-4-DEWALT (+1-800-433-9258).

[www.dewalt.com](http://www.dewalt.com)

A empresa acima identificada é responsável pelo fornecimento do produto, incluindo o Manual de Operação, em condições de total segurança. A empresa referida não é responsável pelos acessórios fabricados por terceiros.

### Responsabilidades da pessoa responsável pelo instrumento:

- Compreender as instruções de segurança do instrumento e as instruções constantes do Manual de Operação.
- Familiarização com os regulamentos locais sobre a prevenção de acidentes.
- Impedir o acesso ao instrumento a pessoas não autorizadas.

## Instruções de segurança

### Utilização correcta

- Medição de distâncias
- Medição de inclinações

### Utilização incorrecta

- Utilização do instrumento sem instruções de uso
- Utilização fora dos limites indicados pelo fabricante
- Desactivação dos sistema de segurança e remoção das etiquetas de informação e de segurança
- Abertura e desmontagem do instrumento com ferramentas de qualquer natureza (chaves de fendas, etc.)
- Modificação ou alteração das características do instrumento
- Utilização com acessórios de outros fabricantes, sem autorização expressa.
- Encandeamento deliberado de outras pessoas, mesmo no escuro
- Condições de segurança inadequadas no local de utilização do instrumento (por exemplo, utilização em vias de circulação, estaleiros de construção, etc.)
- Comportamento deliberado ou irresponsável em andaimes, durante a utilização de escadas, execução de medições junto de máquinas em funcionamento ou nas proximidades de máquinas ou instalações sem protecções de segurança
- Apontamento do instrumento directamente para o sol

### Riscos da utilização

#### ATENÇÃO

Os instrumentos defeituosos, utilizados incorrectamente ou modificados poderão fornecer valores errados. Efectuar medições de teste frequentes.

Especialmente após o instrumento ter sido sujeito a utilização anormal e antes, durante e após quaisquer medições particularmente importantes.

#### AVISO

Não efectuar quaisquer reparações no instrumento. Em caso de anomalia de funcionamento ou avaria, contactar um representante local.

#### ATENÇÃO

As alterações ou modificações funcionais não aprovadas expressamente pelo fabricante podem cancelar a autorização de utilizador utilizar o equipamento.

#### Limites da utilização do instrumento

 Consultar o capítulo “Características Técnicas”.

O instrumento foi concebido para ser utilizado em áreas com ocupação humana permanente. Não utilizar o instrumento em áreas com perigo de explosão ou em ambientes agressivos.

### Eliminação final

#### AVISO

As pilhas esgotadas não devem ser descartadas juntamente com os resíduos domésticos. Proteger o ambiente e descartar as pilhas nos pontos de recolha (“Pilhões”) da sua área de residência.

O instrumento não deve ser descartado juntamente com os resíduos domésticos.

Eliminar o instrumento de acordo com os regulamentos aplicáveis em vigor.



Respeitar os regulamentos nacionais específicos do país.

As instruções para o tratamento específico e a gestão de resíduos podem ser consultadas no nosso sítio Web.

#### Compatibilidade Electromagnética (EMC)

#### ATENÇÃO

O instrumento satisfaz os requisitos mais exigentes das normas e regulamento aplicáveis.

No entanto, não pode ser totalmente excluída a indução de interferências em outros equipamentos.

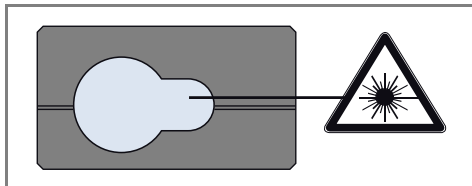
**Classificação do laser**

O instrumento emite feixes de luz laser visível:

O produto é da Classe 2 (produtos laser), de acordo com as seguintes normas:

- IEC60825-1: 2007 "Segurança contra radiações em produtos com laser" (Radiation safety of laser products).

**Produtos laser de Classe 2:**

Não olhar directamente para o raio laser, nem apontar o raio directamente para as outras pessoas. A protecção dos olhos é normalmente assegurada por respostas de aversão, como o pestanejar.

**⚠ ATENÇÃO**

A observação directa do raio com instrumentos ópticos (por exemplo, binóculos, telescópios, etc.) pode ser perigosa.

**⚠ AVISO**

A observação directa do raio laser pode ser perigosa para os olhos.

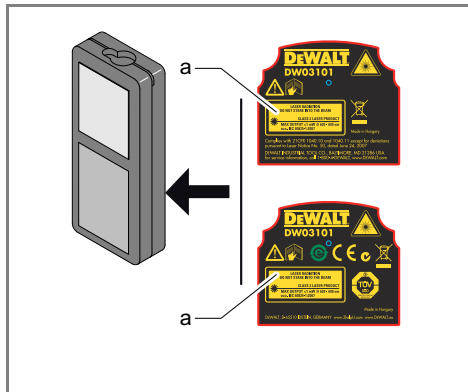
**Marcação do instrumento**

Afixar a etiqueta (a) da língua utilizada.

# Inhoudsopgave

<b>Instrument Instellen</b> .....	<b>2</b>
Introductie .....	2
Overzicht .....	2
Display .....	3
Batterijen inzetten .....	3
<b>Bediening</b> .....	<b>4</b>
AAN/UIT schakelen .....	4
Reset .....	4
Meldingcodes .....	4
Aanpassen meetreferentie / statief .....	4
Multifunctioneel eindstuk .....	5
Instellen eenheden afstand .....	5
Instellen eenheden helling .....	5
Zelfontspanner .....	5
Piep AAN/UIT .....	6
Verlichting AAN/UIT .....	6
<b>Meetfuncties</b> .....	<b>7</b>
Meting enkele afstand .....	7
Permanent / Minimum-Maximum meting .....	7
Optellen / Aftrekken .....	7
Oppervlakte .....	8
Volume .....	9
Opp. driehoek .....	10
Pythagoras (2-punten) .....	11
Pythagoras (3-punten) .....	11
Pythagoras (deelhoogte) .....	12
Uitzetten .....	13
Slimme horizontale modus .....	13
Bepalen hoogte .....	14
Waterpas stellen .....	14
Geheugen (20 laatste resultaten) .....	15

Geheugen wissen .....	15
-----------------------	----

## **Kalibratie** .....

Kalibratie van hellingmeter (Hellingkalibratie) .....	16
---	----

## **Technische gegevens** .....

## **Meldingcodes** .....

## **Verzorging** .....

## **Garantie** .....

## **Veiligheidsvoorschriften** .....

Verantwoordelijkheidsgebieden .....	18
Gebruik volgens de voorschriften .....	19
Gebruik in strijd met de voorschriften .....	19
Gebruiksrisico's .....	19
Toepassingsgrenzen .....	19
Afvalverwerking .....	19
Elektromagnetische compatibiliteit (EMC) .....	19
Laserclassificatie .....	20
Labeling .....	20

# Instrument Instellen

## Introductie

 De veiligheidsinstructies en de handleiding dienen zorgvuldig te worden gelezen, voordat het instrument de eerste keer in gebruik wordt genomen.

 De beheerder moet er op toezien, dat alle gebruikers deze aanwijzingen begrijpen en opvolgen.

De gebruikte symbolen hebben de onderstaande betekenis:

### WAARSCHUWING

Gebruiksgevaar of gebruik in strijd met de voorschriften, dat ernstig letsel of de dood tot gevolg kan hebben.

### VOORZICHTIG

Gebruiksgevaar of gebruik in strijd met de voorschriften, dat slechts gering letsel met zich meebrengt, maar aanzienlijke schade aan materiaal, bezittingen of milieu kan veroorzaken.

 Belangrijke gebruiksinformatie, die de gebruiker helpt, het product technisch juist en efficiënt te gebruiken.

## Overzicht

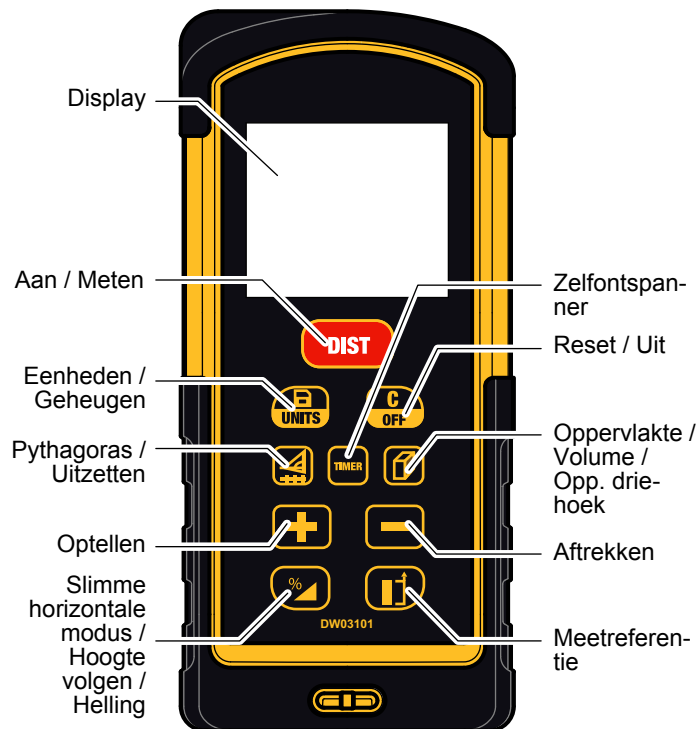

# Instrument Instellen

## Display

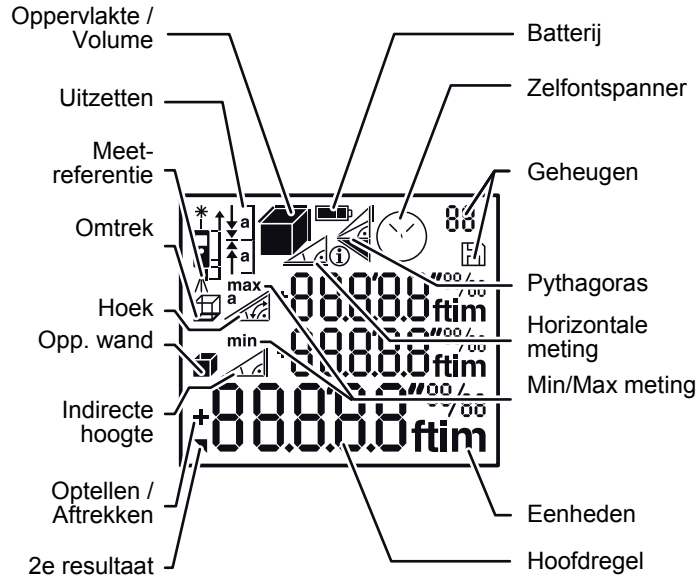

## Batterijen inzetten

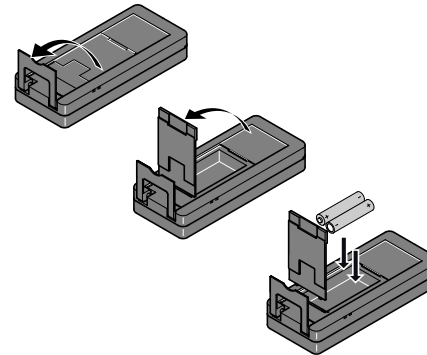

i

Voor een betrouwbare werking **GEEN** zink-koolstof-batterijen gebruiken. Wissel de batterij als het pictogram knippert.

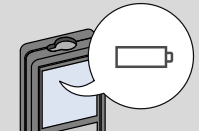

## AAN/UIT schakelen



i

AAN toets 2 sec ingedrukt houden om continu lasermodus te starten. Als gedurende 180 sec geen toets wordt ingedrukt, dan schakelt het apparaat automatisch uit.

## Reset

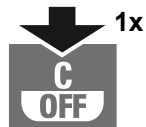

1x  
Laatste actie ongedaan maken.

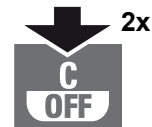

2x  
Huidige functie afsluiten, ga naar standaard modus.

## Meldingcodes

Als het infopictogram verschijnt met een nummer, volg dan de instructies in hoofdstuk "Meldingcodes".  
Voorbeeld:



## Aanpassen meetreferentie / statief

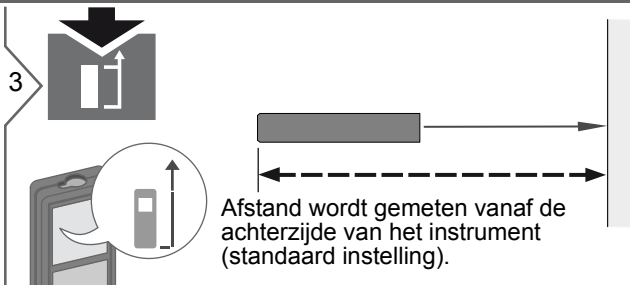
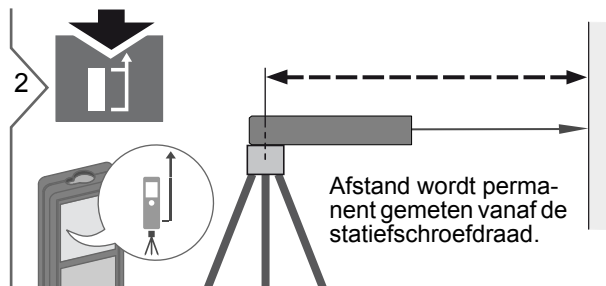
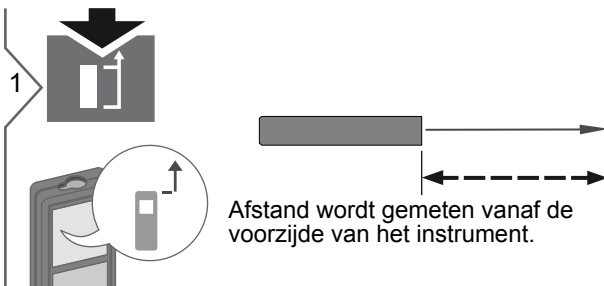

## Bediening

### Multifunctioneel eindstuk

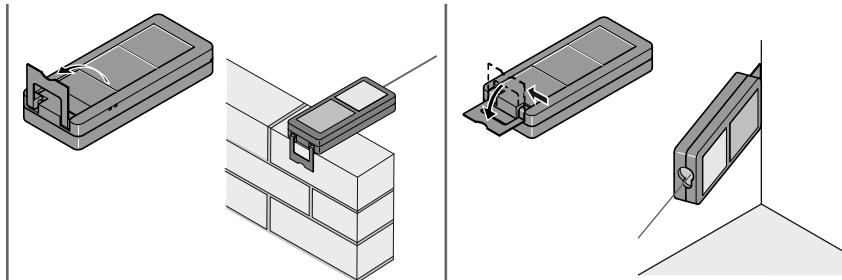

**i** De oriëntatie van het eindstuk wordt automatisch herkend en het juiste nulpunt wordt ingesteld.

### Instellen eenheden afstand



2 sec

Wissel tussen onderstaande eenheden:

0.000 m	0.00 ft
0.0000 m	0'00" 1/32
0.00 m	0.00 in
	0 in 1/32

### Instellen eenheden helling



Tegelijkertijd 2 sec

Wissel tussen onderstaande eenheden:

180 °
0.0 %

### Zelfontspanner

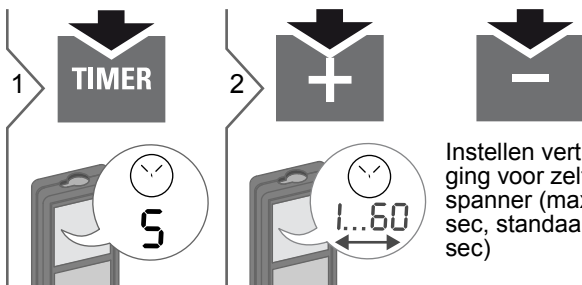

Instellen vertraging voor zelfontspanner (max. 60 sec, standaard 5 sec)

**i** Als de toets wordt losgelaten met ingeschakelde laser, dan worden de resterende seconden tot de meting afgeteld in het display. Gebruik van de zelfontspanner wordt aangeraden voor precies richten, bijv. bij lange afstanden. Dit voorkomt dat het instrument beweegt door indrukken van de meettoets.

# Bediening

## Piep AAN/UIT



Tegelijkertijd  
2 sec

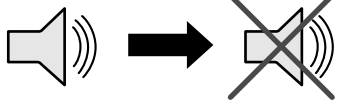

## Verlichting AAN/UIT



Tegelijkertijd  
2 sec

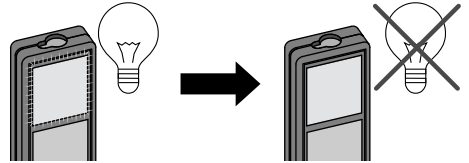

## Meetfuncties

### Meting enkele afstand

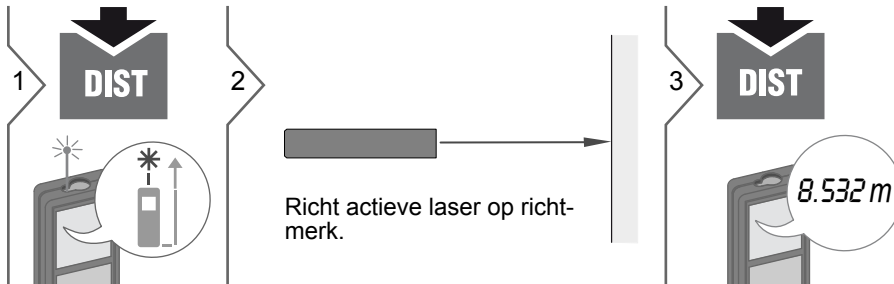

i

Meetoppervlakken: Meetfouten kunnen optreden bij metingen naar kleurloze vloeistoffen, glas, piepschuim of halfdoorlatende oppervlakken, of bij meten op hoogglansoppervlakken. Voor donkere oppervlakken zal de meettijd toenemen.

### Permanent / Minimum-Maximum meting

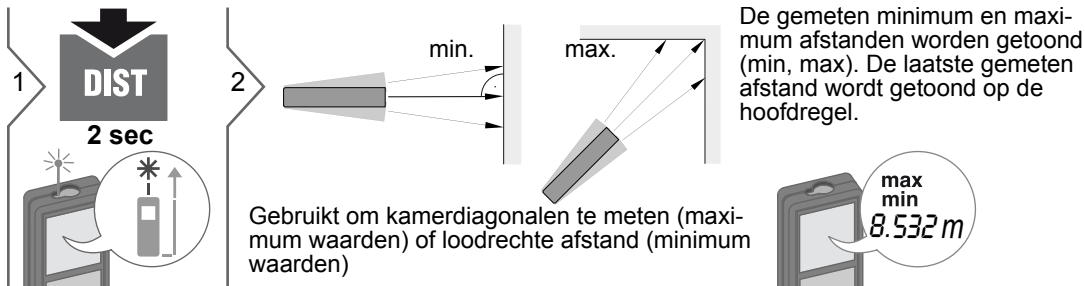

3



Stopt permanent / minimum-maximum meting.

### Optellen / Aftrekken



i

Het resultaat staat op de hoofdregel en de gemeten waarde er boven. Dit proces kan zo vaak als nodig worden herhaald. Dezelfde procedure kan worden gevolgd voor optellen en aftrekken van oppervlakten en volumes.

## Oppervlakte

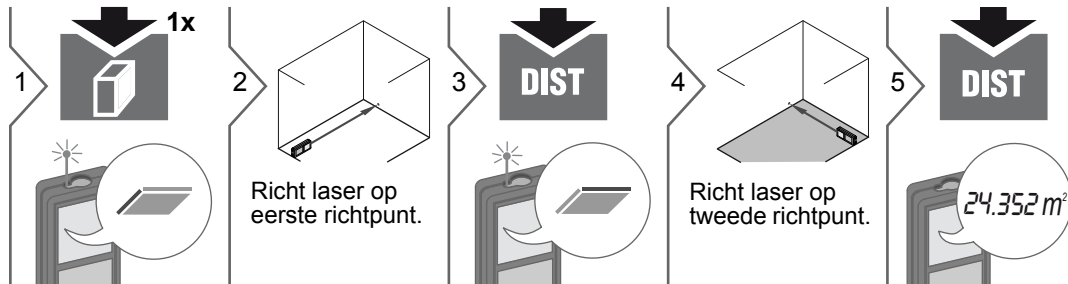

i

Het resultaat staat op de hoofdregel en de gemeten waarde er boven.

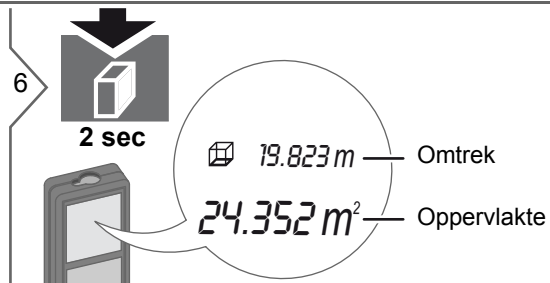

# Meetfuncties

## Volume

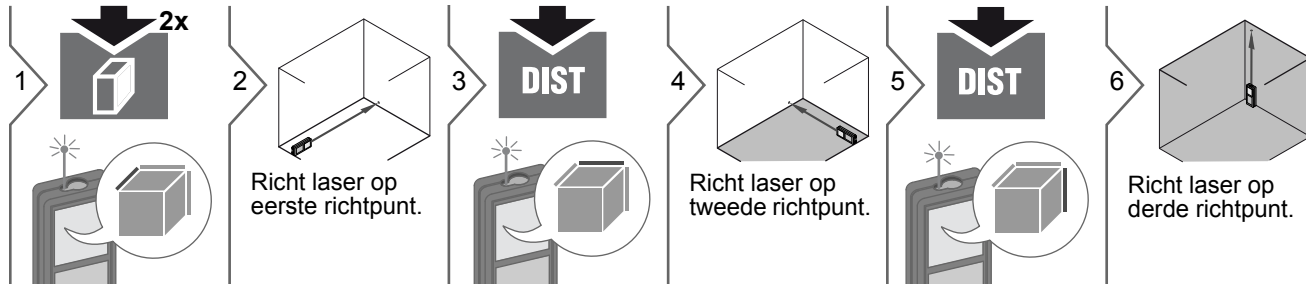

# Meetfuncties

## Opp. driehoek

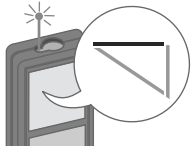
1  

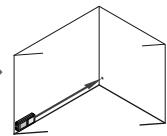
2  Richt laser op eerste richtpunt.

3  

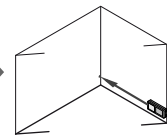

4  Richt laser op tweede richtpunt.

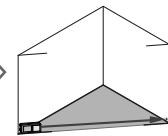
5  

6  Richt laser op derde richtpunt.

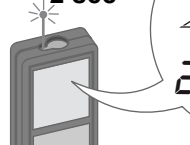
7  

8  

 40.8° — Hoek tussen de eerste twee metingen  
 33.852 m — Omtrek  
 24.352 m² — Opp. driehoek

## Meetfuncties

### Pythagoras (2-punten)

1  Richt laser op bovenste punt.

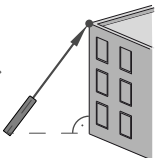
2  Richt laser loodrecht op onderste punt.

3  Richt laser loodrecht op onderste punt.

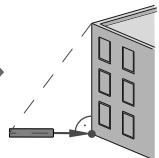
4  Richt laser loodrecht op onderste punt.

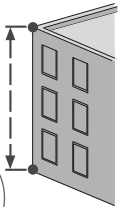
5   8.294 m

**i** Het resultaat staat op de hoofdregel en de gemeten waarde er boven. De meettoets 2 sec ingedrukt houden in de functie, activeert automatisch de Minimum of Maximum meting.

### Pythagoras (3-punten)

1  Richt laser op bovenste punt.

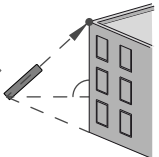
2  Richt laser op loodrecht punt.

3  Richt laser op loodrecht punt.

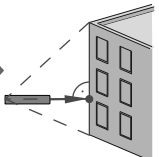
4  Richt laser op onderste punt.

5  Richt laser op onderste punt.

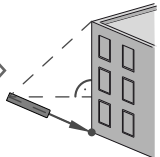
6  Richt laser op onderste punt.

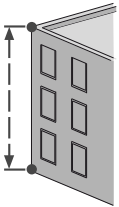
7   8.294 m

**i** Het resultaat staat op de hoofdregel en de gemeten waarde er boven. De meettoets 2 sec ingedrukt houden in de functie, activeert automatisch de Minimum of Maximum meting.

## Pythagoras (deelhoogte)

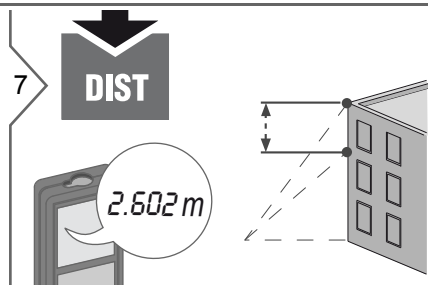
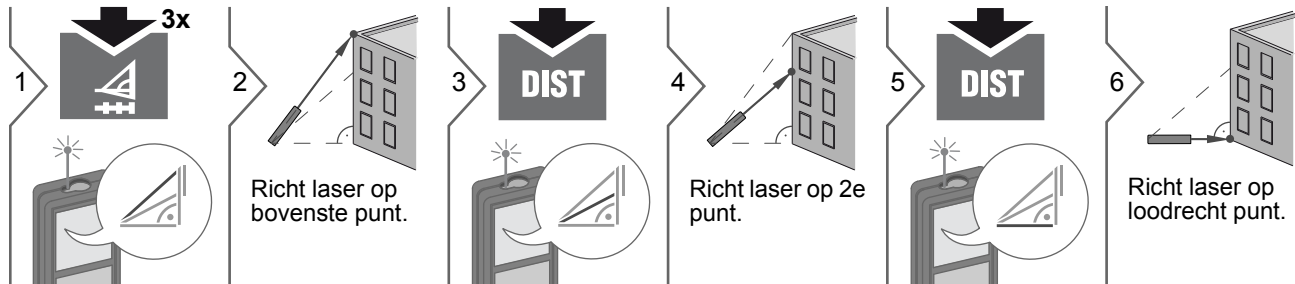

**i**  
Het resultaat staat op de hoofdregel en de gemeten waarde er boven.  
De meettoets 2 sec ingedrukt houden in de functie, activeert automatisch de Minimum of Maximum meting.

## Uitzetten

**1** **4x**

**2** Waarde instellen. **0.625 m**

**3** **DIST** Waarde bevestigen en meting starten.

**4** Beweeg instrument langzaam langs de uitzetlijn. De afstand naar het volgende uitzetpunt wordt getoond. **0.625 m**

**0.240 m** Het is nog 0.240 m tot de volgende 0.625 m afstand.

**i** Het instrument gaat piepen als een uitzetpunt wordt gemeterd binnen 0.1 m. De functie kan worden gestopt door indrukken van de RESET/UIT toets.

## Slimme horizontale modus

**1** **1x**

**2** Richt actieve laser op richtmerk.

**3** **DIST**

**24.3°** —  $\alpha$   
**0.032 m** —  $y$   
**4.827 m** —  $z$

**i** Toets nog eens indrukken om horizontaal meten uit te schakelen.

(tot 360° met een dwarshelling van  $\pm 10^\circ$ )

# Meetfuncties

## Bepalen hoogte

**i** Deze functie toont continu de hoogte als het instrument wordt gerotereerd op een statief. Geen 2e afstandmeting nodig, omdat alleen de helling automatisch wordt gemeten.

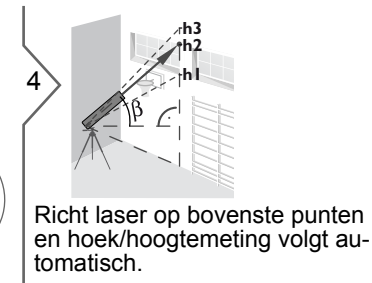
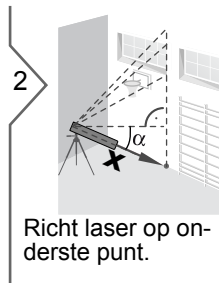
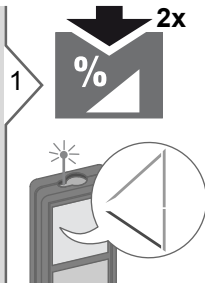

**5**

6.932 m —  $x$

30.2° —  $\beta$  = Actuele helling

9.827 m —  $y$  = Actuele hoogte als instrument wordt gerotereerd op statief

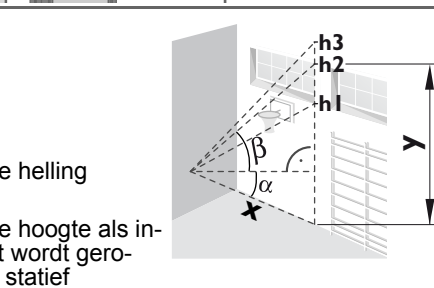

**6**

De actuele hoogte " $y$ " ligt loodrecht boven het 1e richtpunt " $x$ ".



## Waterpas stellen

**i** Deze functie toont continu de helling van het apparaat. Vanaf een helling van  $\pm 5^\circ$  begint het apparaat te piepen. Hoe dichterbij de  $0^\circ$  komt, hoe sneller het piept. Als een helling van  $\pm 0.3^\circ$  wordt bereikt, dan piept het apparaat ononderbroken.

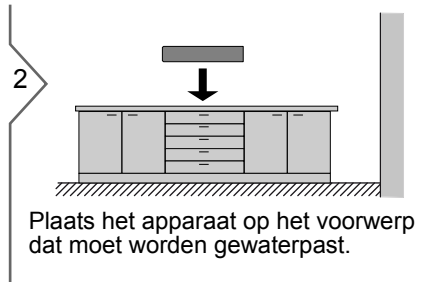
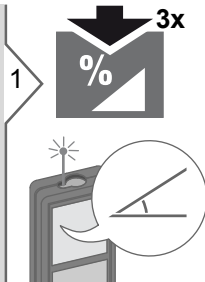

## Meetfuncties

### Geheugen (20 laatste resultaten)

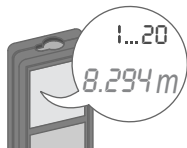
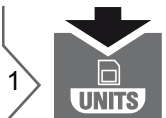

De laatste 20 waarden worden getoond.

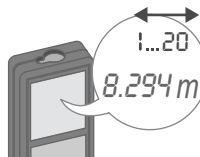

Bladert door de laatste 20 waarden.



**2 sec**

De waarde in de hoofdregel kan worden gebruikt voor verdere berekeningen.

### Geheugen wissen

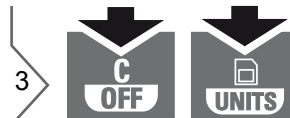



**2 sec tegelijkertijd**

Volledige geheugen wordt gewist.

# Kalibratie

## Kalibratie van hellingmeter (Hellingkalibratie)

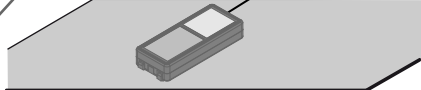

1  Tegelijkertijd 2 sec

 MEAS 1  
HOR  
CAL

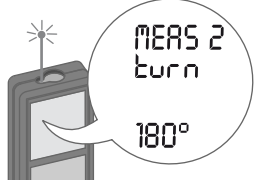
2  Plaats het instrument op een absoluut horizontale ondergrond.

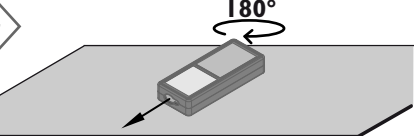
3   MEAS 2  
turn  
180°

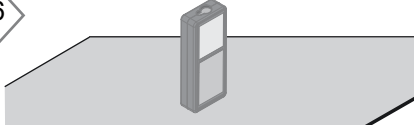

4  180°  
Draai het instrument 180° en zet het weer op de absoluut horizontale ondergrond.

5   MEAS 3  
VER  
CAL

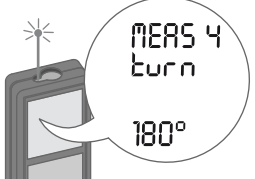
6  Draai het instrument onderste boven en plaats het weer op de absoluut horizontale ondergrond.

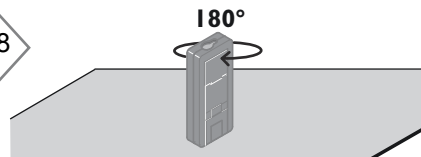
7   MEAS 4  
turn  
180°

8  180°  
Draai het instrument 180° en zet het weer op de absoluut horizontale ondergrond.

9   OK  
CAL

 Na 2 sec schakelt het instrument over naar normale modus.

Afstandmeting	
Gemiddelde meettolerantie *	± 1.0 mm / 0.04 in ***
Gemiddelde meettolerantie **	± 2.0 mm / 0.08 in ***
Bereik met richtplaat	100 m / 330 ft
Gemiddeld bereik*	80 m / 262 ft
Bereik bij ongunstige omstandigheden ****	60 m / 197 ft
Kleinste weergegeven eenheid	0.1 mm / 1/32 in
Ø laserspot op afstanden	6 / 30 / 60 mm (10 / 50 / 100 m)
Hellingmeting	
Meettoleranties tov. laserstraal*****	± 0.2°
Meettoleranties tov. behuizing*****	± 0.2°
Bereik	360°
Algemeen	
Laserklasse	2
Lasertype	635 nm, < 1 mW
Straaldivergentie	0.16 x 0.6 mrad
Pulsduur	0.2 x 10 <sup>-9</sup> s - 0.8 x 10 <sup>-9</sup> s
Beschermingsklasse	IP54 (stof- en spatwaterdicht)
Autom. laser uitschakelen	na 90 s
Automatisch uitschakelen	na 180 s
Levensduur batterijen (2 x AAA)	tot 5000 metingen
Afmetingen (h x d x b)	125.2 x 58 x 32.6 mm 4.9 x 2.3 x 1.3 in
Gewicht (met batterijen)	154 g / 5.43 oz
Temperatuurbereik:	
- Opslag	-25 tot 70 °C -13 tot 158 °F
- Werking	-10 tot 50 °C 14 tot 122 °F

\* van toepassing bij 100 % richtmerkreflectie (witgeverfde muur), weinig omgevingslicht, 25 °C

\*\* van toepassing bij 10 tot 500 % richtmerkreflectie, veel omgevingslicht, - 10 °C tot + 50 °C

\*\*\* Toleranties van toepassing van 0.05 m tot 10 m met een betrouwbaarheidsniveau van 95%. De maximale tolerantie kan oplopen tot 0.1 mm/m tussen 10 m en 30 m en tot 0.2 mm/m voor afstanden boven 30 m

\*\*\*\* van toepassing bij 100 % richtmerkreflectie, omgevingslicht van circa 30'000 lux

\*\*\*\*\* na kalibratie door gebruiker. Extra hoekgerelateerde afwijking van +/- 0,01° per graad tot +/-45° in elk kwadrant. Van toepassing bij kamertemperatuur. Voor het gehele werktemperatuurbereik neemt de maximale afwijking toe met +/- 0.1°.

- i Voor nauwkeurige indirecte resultaten wordt gebruik van een statief aangeraden. Voor nauwkeurige hellingmetingen moet een dwarshelling worden vermeden.

Functies	
Afstandmeting	ja
Min/Max meting	ja
Permanente meting	ja
Uitzetten	ja
Optellen/Aftrekken	ja
Oppervlakte	ja
Volume	ja
Pythagoras	2-punt, 3-punt, deel-hoogte
Slimme horizontale modus / Indirecte hoogte	ja
Bepalen hoogte	ja
Waterpassing	ja
Geheugen	20 waarden
Piep	ja
Displayverlichting	ja
Multifunctioneel eindstuk	ja

## Meldingcodes

Als de melding **Error** niet verdwijnt na herhaaldelijk opnieuw inschakelen van het instrument, neem dan contact op met uw dealer.

Als de melding **InFo** verschijnt met een nummer, druk dan op de Reset toets en volg onderstaande instructies:

Nr.	Oorzaak	Oplossing
156	Dwarshelling groter dan 10°	Houd het instrument vast zonder dwarshelling.
162	Kalibratiefout	Let op, dat het instrument op een absoluut horizontale en vlakke ondergrond ligt. Herhaal de kalibratieprocedure. Neem contact op met uw dealer als de fout blijft optreden.
204	Rekenfout	Meting herhalen.
252	Temperatuur te hoog	Instrument af laten koelen.
253	Temperatuur te laag	Instrument opwarmen.
255	Retoursignaal te zwak, meettijd te lang	Wijzig het richtoppervlak (bijv. wit papier).
256	Retoursignaal te sterk	Wijzig het richtoppervlak (bijv. wit papier).
257	Te veel omgevingslicht	Richtgebied afschermen (schaduw).
258	Meting buiten meetbereik	Corrigeer het bereik.
260	Laserstraal onderbroken	Meting herhalen.

## Verzorging

- Het instrument reinigen met een vochtige, zachte doek.
- Het instrument nooit onder water dompelen.
- Nooit agressieve schoonmaak- of oplosmiddelen gebruiken.

## Garantie

### Europa:

- 30 dagen "Niet goed, geld terug"
  - Een jaar gratis onderhoud
  - Een jaar volledige garantie
- Gedetailleerde informatie is beschikbaar op het internet op [www.2helpU.com](http://www.2helpU.com).

### Noord Amerika:

- Drie jaar beperkte garantie
  - Een jaar gratis onderhoud
  - 90 dagen "Niet goed, geld terug"
- Gedetailleerde informatie is beschikbaar op het internet op [www.dewalt.com](http://www.dewalt.com).

## Veiligheidsvoorschriften

De beheerder van het instrument moet er op toezien, dat alle gebruikers de instructies begrijpen en opvolgen.

### Verantwoordelijkheidsgebieden

#### Verantwoordelijkheden van de fabrikant van de oorspronkelijke apparatuur:

Europa:  
DEWALT  
D-65510 Idstein, Germany  
[www.2helpU.com](http://www.2helpU.com)  
[www.dewalt.eu](http://www.dewalt.eu)

Noord Amerika:  
DEWALT Industrial Tool Co.  
Baltimore, MD21286, USA  
Voor assistentie bel 1-800-4-DEWALT.  
[www.dewalt.com](http://www.dewalt.com)

Bovenstaand bedrijf is verantwoordelijk voor de veiligheidstechnisch onberispelijke levering van het product, inclusief gebruiksaanwijzing. Het bedrijf is niet verantwoordelijk voor accessoires van derden.

#### Verantwoordelijkheden van de beheerder van het instrument:

- Hij begrijpt de veiligheidsinformatie voor het product en de instructies in de gebruiksaanwijzing.
- Hij is bekend met de plaatselijke veiligheidsvoorschriften ter voorkoming van ongevallen.

## Veiligheidsvoorschriften

- Hij voorkomt gebruik van het instrument door onbevoegden.

### Gebruik volgens de voorschriften

- Meten van afstanden
- Hellingmeting

### Gebruik in strijd met de voorschriften

- Gebruik van het product zonder instructie
- Gebruik buiten de toepassingsgrenzen
- Onwerkzaam maken van veiligheidsinrichtingen en verwijderen van aanwijzings- en waarschuwingsetiketten
- Openen van het product met gereedschap (schroevendraaier, etc.)
- Het aanbrengen van modificaties of wijzigingen aan het product
- Gebruik van toebehoren van andere fabrikanten zonder nadrukkelijke goedkeuring
- Opzettelijk verblinden van derden; ook in het donker
- Onvoldoende beveiliging van de meetlocatie (bijv.: bij het verrichten van metingen op straat, constructielocaties, etc.)
- Opzettelijk of onverantwoord gedrag op steigers, bij het beklimmen van ladders, bij het meten in de buurt van draaiende machines of open machine-elementen of installaties
- Direct richten in de zon

## Gebruiksrisico's

### WAARSCHUWING

Pas op voor foutieve metingen bij gebruik van een defect product, na een val of andere niet toegestane belastingen resp. modificaties aan het product. Verricht periodiek controlemetingen.

Vooral na overbelasting van het product, en voor en na belangrijke meettaken.

### VOORZICHTIG

Probeer nooit zelf het instrument te repareren. Neem contact op met uw dealer in geval van schade.

### WAARSCHUWING

Wijzigingen of modificaties, die niet nadrukkelijk zijn goedgekeurd, kunnen de gebruiker het recht ontnemen om het instrument te gebruiken.

### Toepassingsgrenzen

- Zie de "Technische gegevens".
- Het instrument is bedoeld voor toepassing in gebieden, die geschikt zijn voor permanente menselijke bewoning. Gebruik het instrument niet in gebieden met explosiegevaar of in agressieve omgevingen.

## Afvalverwerking

### VOORZICHTIG

Lege batterijen mogen niet bij het huisvuil worden weggegooid. Denk aan het milieu en lever ze in bij de beschikbare inzamelpunten in overeenstemming met nationale en lokale regels.

Het product mag niet bij het huisvuil worden weggegooid.

Het product moet in overeenstemming met de nationale regelgeving van uw land worden verwijderd.



Houdt u aan de nationale en land-specifieke regelgeving.

Productspecifieke informatie met betrekking tot behandeling en afvalverwerking kan worden gedownload van onze homepage.

### Elektromagnetische compatibiliteit (EMC)

### WAARSCHUWING

Het instrument voldoet aan de strengste eisen van de relevante normen en regelgeving.

Desondanks kan de mogelijkheid op storing in andere apparatuur niet volledig worden uitgesloten.

# Veiligheidsvoorschriften

## Laserclassificatie

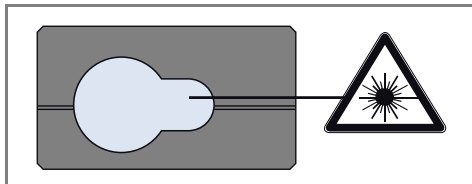

Het instrument produceert zichtbare laserstralen, die uit het apparaat naar buiten schijnen:

Het is een klasse 2 laserproduct volgens:

- IEC60825-1 : 2007 "Veiligheid van laserrichtingen"

### Laserklasse 2 producten:

Kijk niet in de laserstraal en richt niet onnodig op andere personen. Oogbescherming wordt gewoonlijk bewerkstelligd door afwendingreacties inclusief knipperreflex.

### **⚠ WAARSCHUWING**

Direct in de laserstraal kijken met optische hulpmiddelen (zoals bijv. verrekijkers, telescopen) kan gevaarlijk zijn.

### **⚠ VOORZICHTIG**

Het kijken in de laserstraal kan gevaarlijk zijn voor de ogen.

## Labeling

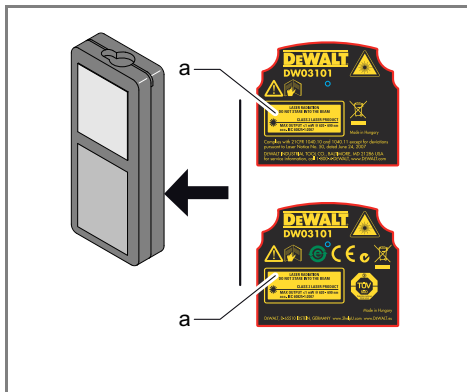

Bevestig de lasersticker (a) in uw landstaal.

# Indholdsfortegnelse

<b>Instrumentopsætning</b> .....	<b>2</b>
Introduktion- .....	2
Oversigt .....	2
Display .....	3
Sæt batterier i .....	3
<b>Betjening</b> .....	<b>4</b>
Tænde og slukke- .....	4
Clear .....	4
Meddelseskoder .....	4
Indstilling af måle-reference / stativ .....	4
Multifunktionelt endestykke .....	5
Afstandsneheds-indstilling .....	5
Hældningsneheds-indstilling- .....	5
Timer (automatisk start) .....	5
Tænde og slukke lyd .....	6
Tænde og slukke belysning .....	6
<b>Målefunktioner</b> .....	<b>7</b>
Måle enkelt afstand .....	7
Permanent / Minimum-Maksimum-måling .....	7
Plus / minus .....	7
Areal .....	8
Volumen .....	9
Trekant areal .....	10
Pythagoras (2-punkt) .....	11
Pythagoras (3-punkt) .....	11
Pythagoras (del-højde) .....	12
Opmåling .....	13
Smart Horisontal Mode .....	13
Højdesporing .....	14
Nivellering .....	14
Memory (20 seneste resultater) .....	15

Slet memory .....	15
-------------------	----

## Kalibrering .....

Kalibrering af hældningssensor (hældningskalibrering) .....	16
--	----

## Tekniske specificationer .....

## Meddelseskoder .....

## Vedligeholdelse .....

## Garanti .....

## Sikkerhedsanvisninger .....

Ansvarsområder .....	18
Tilladt brug .....	19
Ikke-tilladt anvendelse .....	19
Farer ved brug .....	19
Begrænsninger for brug .....	19
Bortskaffelse .....	19
Elektromagnetisk kompatibilitet (EMC) .....	19
Laserklassifikation .....	20
Mærkning .....	20

# Instrumentopsætning

## Introduktion

 Sikkerhedsanvisningerne og brugervejledningen bør læses omhyggeligt, før produktet anvendes første gang.

 Personen med ansvar for produktet skal sørge for at alle brugere forstår disse anvisninger og følger dem.

De anvendte symboler har følgende betydninger:

### ADVARSEL

Angiver en potentielt farlig situation eller en utilsigtet brug, som vil føre til død eller alvorlig personskade, hvis den ikke undgås.

### FORSIGTIG

Angiver en potentielt farlig situation eller en utilsigtet brug, som vil føre til mindre personskade og/eller væsentlig materiel, økonomisk og miljømæssig skade, hvis den ikke undgås.

 Vigtigt afsnit som skal følges i praksis for at produktet kan anvendes på en teknisk korrekt og effektiv måde.

## Oversigt

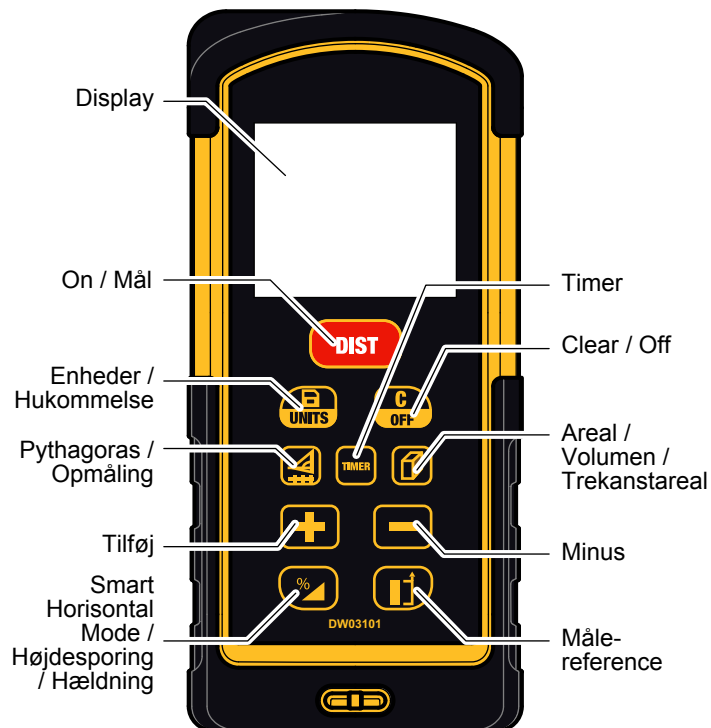

## Display

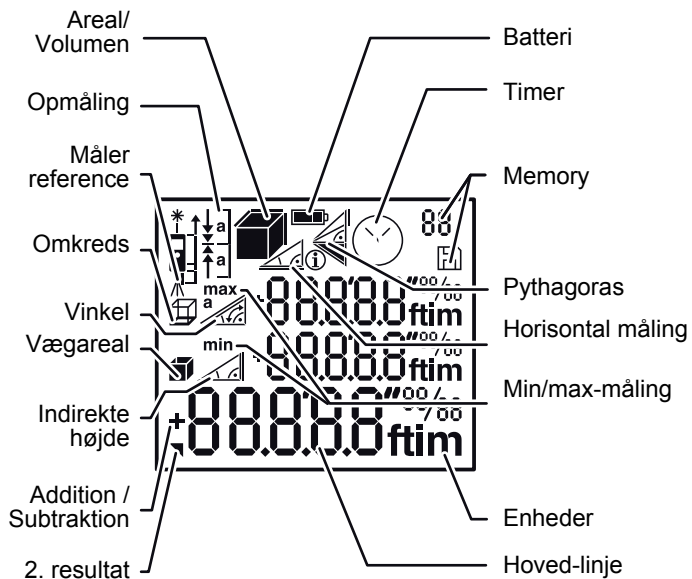

## Sæt batterier i

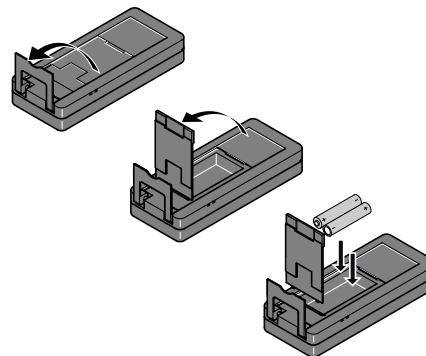
**i**

For at sikre driftsikkerhed bør der ikke anvendes zink-kul batterier. Skift batterierne når batterisymbolet blinker.

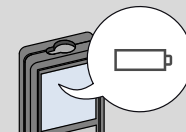

## Tænde og slukke



2 sek.

Apparat slukkes.

i

Tryk på ON-knappen i 2 sek. for at starte kontinuert laser-mode. Hvis der ikke trykkes på nogen tast i 180 sek. vil apparatet automatisk slukkes.

## Clear

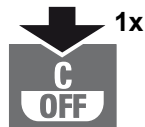

1x

Fortryd seneste handling.

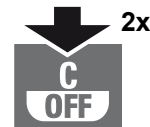

2x

Forlad aktuell funktion og gå til default betjenings-mode.

## Meddeleseskoder

Hvis "Info"-ikonet kommer frem med et nummer, følges anvisningerne i afsnittet "Meddeleseskoder".

Eksempel:



## Indstilling af måle-reference / stativ

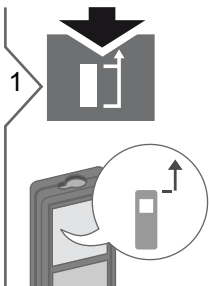

1

Afstand måles fra apparatets front.

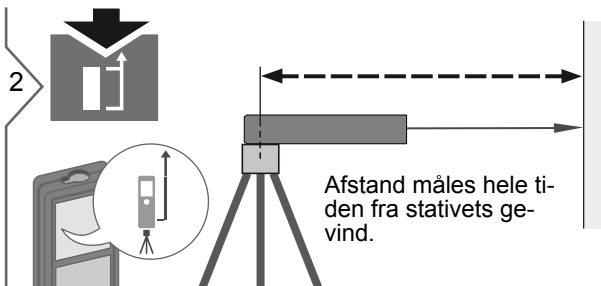

2

Afstand måles hele tiden fra stativets gevind.

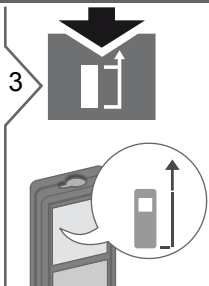

3

Afstand måles fra apparatets bagside (standardindstilling).

# Betjening

## Multifunktionelt endestykke

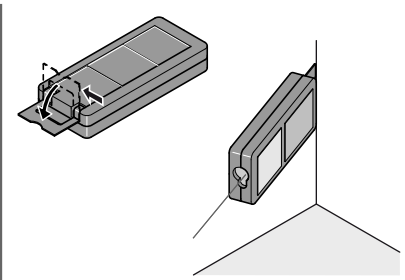
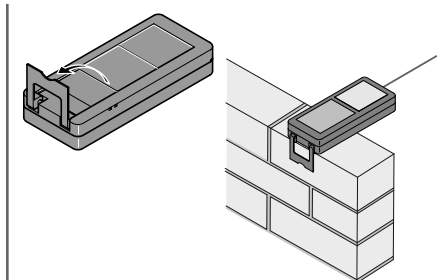

**i** Endestykkets retning spores automatisk og nulpunkt indstilles tilsvarende.

## Afstandsenheds-indstilling



2 sek.

Skift mellem følgende enheder:

0.000 m	0.00 ft
0.0000 m	0'00" 1/32
0.00 m	0.00 in
	0 in 1/32

## Hældningsenheds-indstilling



2 sek. samtidigt



Skift mellem følgende enheder:

180 °
0.0 %

## Timer (automatisk start)

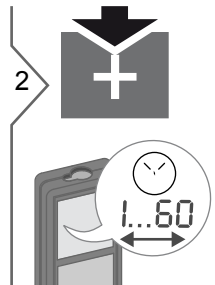
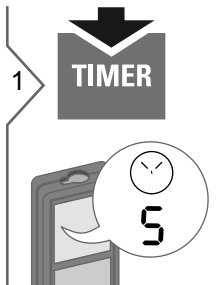

**3**

start forsinkelse for automatisk release (max. 60 sek., standardindstilling 5 sek.)

**i** Når der er trykket på tasten, mens laseren er aktiv, vil de resterende sekunder indtil måling blive vist som en nedtælling. Den forsinkede timerstart anbefales til præcist sigte f.eks. ved lange afstande. Derved undgås det at ryste apparatet, når der trykkes på måletasten.

**Betjening****Tænde og slukke lyd**

2 sek.  
samtidigt

**Tænde og slukke belysning**

2 sek.  
samtidigt

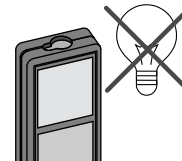
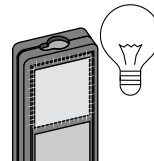

# Målefunktioner

## Måle enkelt afstand

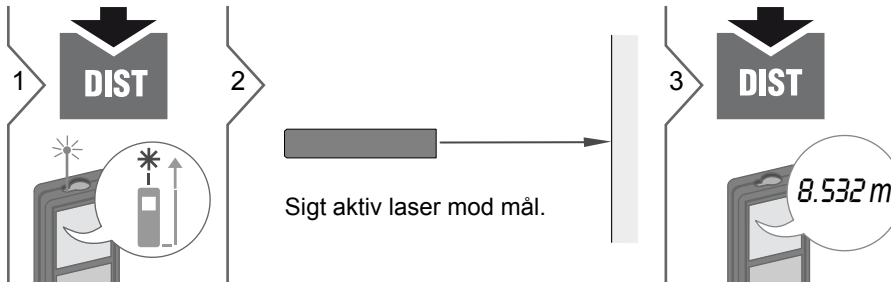

**i** Mål-overflader: Målefejl kan opstå, når der måles til farveløse væsker, glas, styrofoam eller halvgennemsigtige overflader eller ved sigte mod meget reflekterende overflader. Måling tager længere tid mod mørke overflader.

## Permanent / Minimum-Maksimum-måling

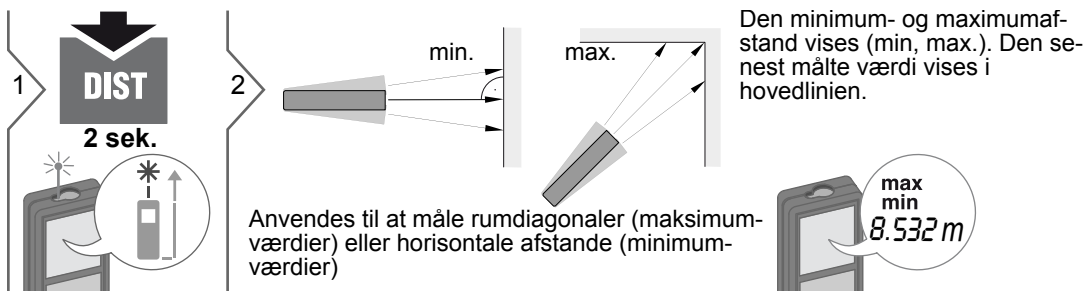

**i** Stopper permanent / minimum-maksimum måling.

## Plus / minus



**i** Resultatet vises i hovedlinien og den målte værdi ovenover. Denne proces kan gentages efter behov. Den samme proces kan anvendes til at lægge til eller trække fra for arealer og volumener.

## Areal

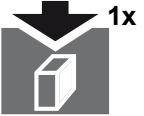
1  1x

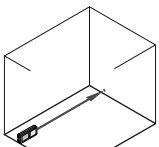
2  Ret laser mod første målpunkt.

3  DIST

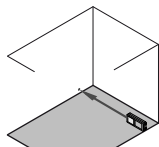
4  Ret laser mod andet målpunkt.

5  DIST

 24.352 m<sup>2</sup>

**i** Resultatet vises i hovedlinien og den målte værdi ovenover.

6  2 sek.

 19.823 m — Omkreds  
24.352 m<sup>2</sup> — Areal

# Målefunktioner

## Volumen

1 2 3 4 6

Ret laser mod første målpunkt.

Ret laser mod andet målpunkt.

Ret laser mod tredje målpunkt.

7 8

Resultatet vises i hovedlinjen og den målte værdi ovenover.

**78.694 m<sup>3</sup>**

**80.208 m** — Omkreds  
**208.703 m<sup>2</sup>** — Vægarealer  
**78.694 m<sup>3</sup>** — Volumen

## Trekant areal

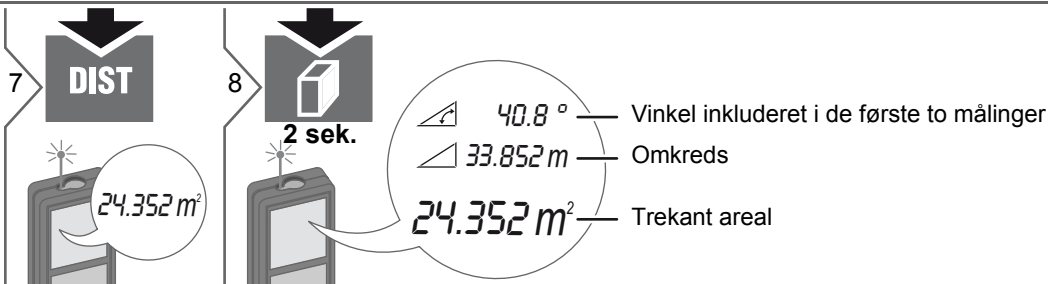
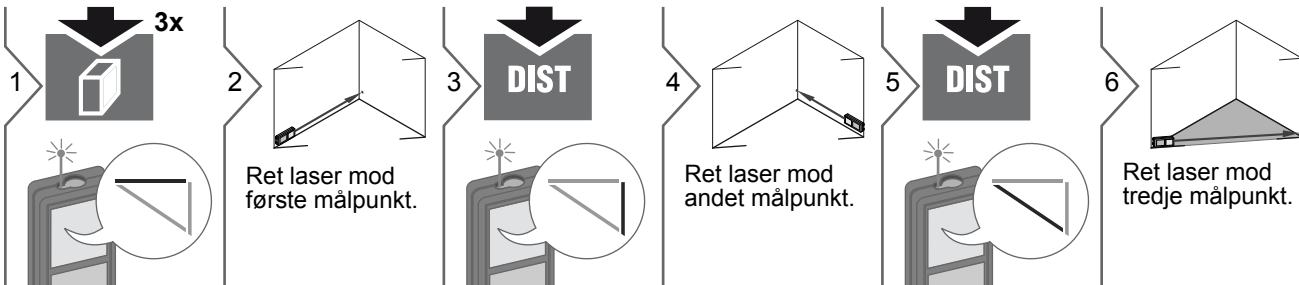

## Målefunktioner

### Pythagoras (2-punkt)

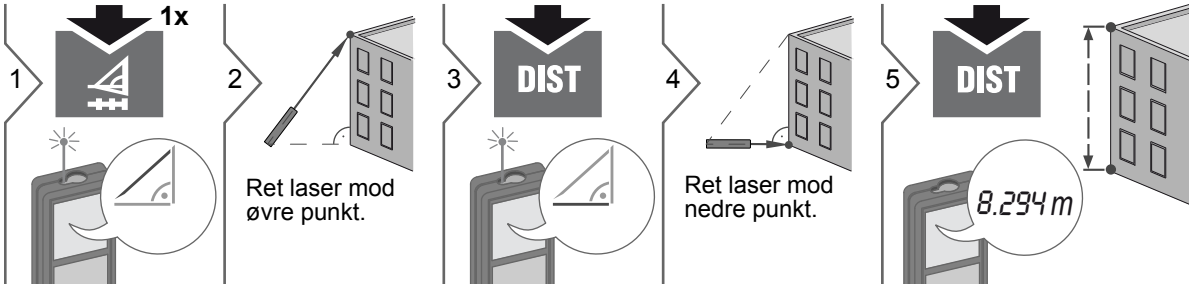

**i** Resultatet vises i hovedlinjen og den målte værdi ovenover. Tryk på måletasten i 2 sek. i funktionen aktiverer automatisk Minimum eller Maksimum måling.

### Pythagoras (3-punkt)

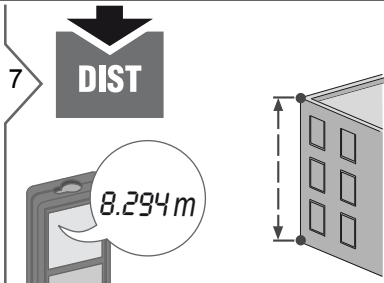
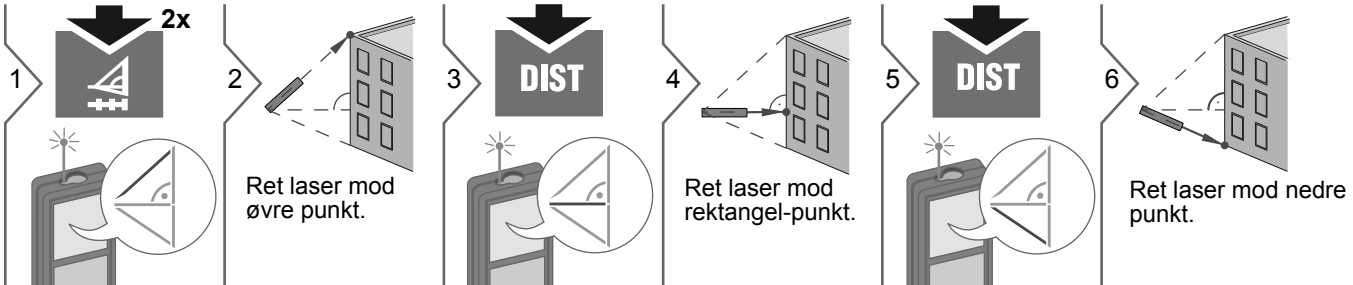

**i** Resultatet vises i hovedlinjen og den målte værdi ovenover. Tryk på måletasten i 2 sek. i funktionen aktiverer automatisk Minimum eller Maksimum måling.

## Pythagoras (del-højde)

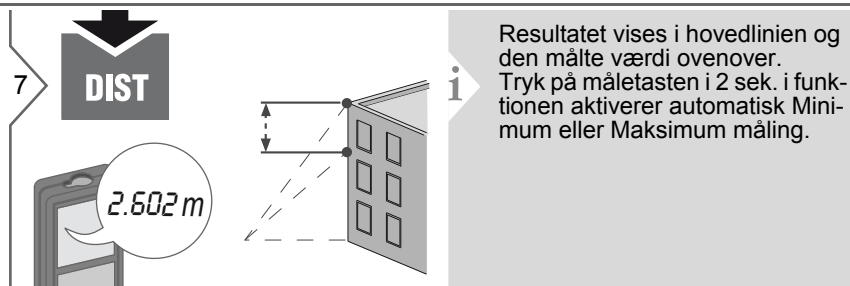
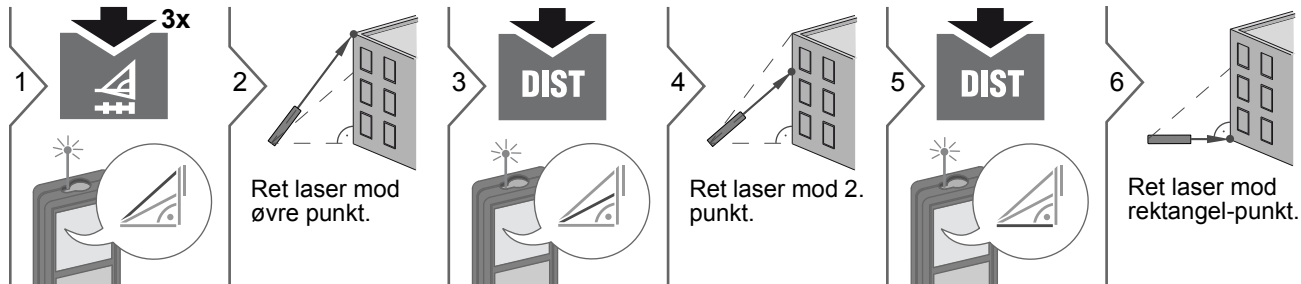

## Opmåling

**1**

**2** Indstil værdi.

**3** Godkend værdi og start måling.

**4** Bevæg apparatet langsomt langs opmålingslinjen. Afstanden til det næste opmålingspunkt vises.

**i** Når instrumentet kommer nærmere end 0,1 m til et opmålingspunkt, begynder det at bippe. Denne funktion kan stoppes ved at trykke på CLEAR/OFF-knappen.

0,240 m mangler op til næste 0,625 m afstand.

## Smart Horizontal Mode

**1**

**2** Sigt laser mod mål.

**3**

**i** Tryk tast igen for at slå horisontal måling fra.

$\alpha$   $24.3^\circ$   
 $y$   $0.032\text{ m}$   
 $z$   $4.827\text{ m}$

(op til 360° og en tværgående hældning på  $\pm 10^\circ$ )

# Målefunktioner

## Højdesporing

**1** Denne funktion viser konstant sporingshøjden, hvis apparatet er sat på et stativ. Der er ikke behov for en anden måling, da kun vinklen måles automatisk.

**2** Ret laser mod nedre punkt.

**3** **DIST**

**4** Sigt laser mod øvre punkter og vinkel/højdesporing starter automatisk.

**5**  $6.932\text{ m}$  —  $x$   
 $30.2^\circ$  —  $\beta$  = Sporingsvinkel  
 $9.827\text{ m}$  —  $y$  = Sporingshøjde hvis apparatet er sat på stativ

Den sporede højde " $y$ " er  $90^\circ$  i forhold til 1. sigtede punkt " $x$ ".

**6** **DIST**

Stopper højdesporing og viser seneste måling.

## Nivellering

**1** Denne funktion viser kontinuert hældning for apparatet. Fra en hældning på  $\pm 5^\circ$  begynder enheden at give bip med jævne mellemrum. Jo mere den kommer mod  $0^\circ$ , jo hurtigere giver den bip. Hvis der nåes en hældning på  $\pm 0.3^\circ$  bipper enheden konstant.

**2** Placer apparat på emne, der skal nivelleres.

Hældningen vises (Område  $\pm 180^\circ$ ).

$8.7^\circ$

## Målefunktioner

### Memory (20 seneste resultater)



1



20 seneste værdier vises.



2



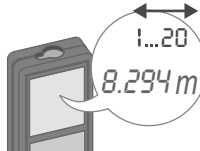

Bladrer gennem seneste 20 værdier.



### Slet memory

3



**2 sek.**

Værdien fra hovedlinjen kan anvendes til yderligere beregninger.





**2 sek. samtidigt**

Memory slettes helt.

# Kalibrering

## Kalibrering af hældningssensor (hældningskalibrering)

1  **2 sek. samtidigt**

 MEAS 1  
HOR  
CAL

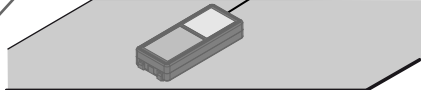
2  Placer apparatet på en helt flad overflade.

3  **DIST**

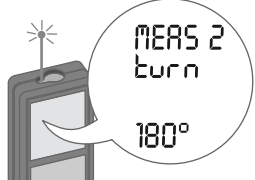
 MEAS 2  
turn  
180°

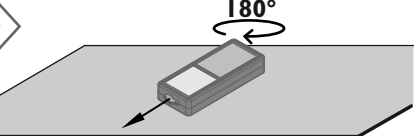
4  180°

Drej apparatet horisontalt 180° og placér det igen på en helt flad overflade.

5  **DIST**

 MEAS 3  
VER  
CAL

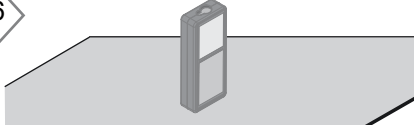
6  Vend apparatet på hovedet og placér det igen på helt flad overflade.

7  **DIST**

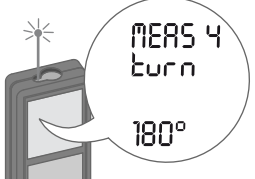
 MEAS 4  
turn  
180°

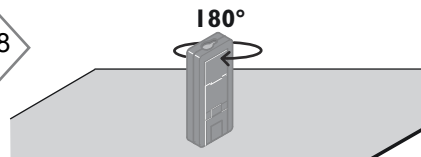
8  180°

Drej apparatet horisontalt 180° og placér det igen på en helt flad overflade.

9  **DIST**

 OK  
CAL

 Efter 2 sek. går apparatet tilbage til normal mode.

# Tekniske specifikationer

Afstandsmåling	
Typisk måletolerance*	± 1.0 mm / 0.04 in ***
Maksimum måletolerance**	± 2,0 mm / 0,08 in ***
Rækkevidde for målplade	100 m / 330 fod
Typisk område *	80 m / 262 fod
Rækkevidde ved ugunstige forhold ****	60 m / 197 fod
Mindste enhed vist	0,1 mm / 1/32 in
Ø laserpunkt ved afstande	6 / 30 / 60 mm (10 / 50 / 100 m)
Hældningsmåling	
Måletolerance for laserstråle*****	± 0.2°
Måletolerance i forhold til kabinet*****	± 0.2°
Område	360°
Generelt	
Laserklasse	2
Lasertype	635 nm, < 1 mW
Stråle-afvigelse	0,16 x 0,6 mrad
Impuls-varighed	0,2 x 10 <sup>-9</sup> s - 0,8 x 10 <sup>-9</sup> s
Beskyttelsesklasse	IP54 (støv- og vandstænk-beskyttet)
Autom. laser-slukning	efter 90 s
Autom. instrument-slukning	efter 180 s
Batterikapacitet (2 x AAA)	op til 5000 målinger
Dimensioner (H x D x B)	125.2 x 58 x 32.6 mm 4.9 x 2.3 x 1.3 in
Vægt (med batterier)	154 g / 5.43 ounce
Temperaturområde:	
- Opbevaring	-25 til 70 °C -13 til 158 °F
- Anvendelse	-10 til 50 °C 14 til 122 °F

\* gælder for 100 % målreflektion (hvidmalet væg), lav baggrundsbelysning, 25 °C

\*\* gælder for 10 til 500 % målreflektion, høj baggrundsbelysning, - 10 °C til + 50 °C

\*\*\* Tolerancer gælder fra 0,05 m til 10 m med et konfidensniveau på 95%. Den maksimale tolerance kan afvige 0.1 mm/m mellem 10 m til 30 m og 0.2 mm/m for afstande over 30 m

\*\*\*\* gælder for 100 % målreflektion, baggrundsbelysning på omkring 30.000 lux

\*\*\*\*\* efter bruger-kalibrering. Yderligere vinkelrelateret afvigelse på +/- 0,01° pr grad op til +/-45° i hver kvadrat. Gælder ved rumtemperatur. For hele drift-temperaturområdet øges maksimum afvigelse med +/- 0.1°.

i For præcise indirekte resultater anbefales brug af stativ. For præcise hældningsmålinger bør tværgående hældning undgås.

Funktioner	
Afstandsmåling	ja
Min/max-måling	ja
Permanent måling	ja
Opmåling	ja
Plus / Minus	ja
Areal	ja
Volumen	ja
Pythagoras	2-punkt, 3-punkt, partiel højde
Smart Horizontal Mode Indirekte højde	ja
Højdesporing	ja
Nivellering	ja
Memory	20 visninger
Bip	ja
Belyst display	ja
Multifunktionelt endestykke	ja

## Meddeleseskoder

Hvis meddelelsen **Error** ikke forsvinder, efter at instrumentet er blevet tændt og slukket adskillige gange, kontaktes forhandleren.

Hvis meddelelsen **InFo** vises med et nummer, trykkes på Clear-knappen og følgende anvisninger følges:

Nr.	Årsag	Udbedring
156	Tværgående hældning større end 10°	Kontroller og juster instrumentets tværgående hældning.
162	Kalibreringsfejl	Sørg for at apparatet er placeret på en helt horisontal og flad overflade. Gentag kalibreringsproceduren. Hvis fejlen opstår igen, kontaktes din forhandler.
204	Beregningsfejl	Udfør måling igen.
252	Temperatur for høj	Lad instrumentet køle ned.
253	Temperatur for lav	Varm instrumentet op.
255	Modtager for svagt signal, måletid for lang	Skift mål-overflade (f.eks. hvidt papir).
256	Modtaget signal for kraftigt	Skift mål-overflade (f.eks. hvidt papir).
257	For meget baggrundsls	Skyg for målområde.
258	Måling udenfor måleområde	Korrekt område.
260	Laserstråle brudt	Gentag måling.

## Vedligeholdelse

- Rengør instrumentet med fugtig, blød klud.
- Instrumentet må ikke nedsænkes i vand.
- Brug aldrig kraftige rengøringsmidler eller opløsninger.

## Garanti

### Europa:

- 30 dage uden risiko tilfredshedsgaranti
- Et års gratis service
- Et års fuld garanti

Detaljeret information tilgængelig on internettet på [www.2helpU.com](http://www.2helpU.com).

### Nordamerika:

- Tre års begrænset garanti
- Et års gratis service
- 90 dages pengene-tilbage-garanti

Detaljeret information tilgængelig on internettet på [www.dewalt.com](http://www.dewalt.com).

## Sikkerhedsanvisninger

Personen med ansvar for instrumentet skal sørge for at alle brugere forstår disse anvisninger og følger dem.

### Ansvarsområder

#### Ansvar for producenten af det originale udstyr:

Europa:  
DEWALT  
D-65510 Idstein, Germany  
[www.2helpU.com](http://www.2helpU.com)  
[www.dewalt.eu](http://www.dewalt.eu)

Nordamerika:  
DEWALT Industrial Tool Co.  
Baltimore, MD21286, USA  
Ring 1-800-4-DEWALT for service.  
[www.dewalt.com](http://www.dewalt.com)

Virksomheden ovenfor er ansvarlig for at levere produktet, incl. brugervejledning, i komplet sikker tilstand. Virksomheden ovenfor er ikke ansvarlig for tredjeparts-tilbehør.

#### Ansvarsområder for personen med ansvar for instrumentet:

- At forstå sikkerhedsanvisningerne på produktet og instruktionerne i brugervejledningen.
- At være bekendt med lokale sikkerhedsregler mht. ulykkesforebyggelse.
- Altid at undgå at uautoriserede personer får adgang til produktet.

## Sikkerhedsanvisninger

### Tilladt brug

- Afstandsmåling
- Hældningsmåling

### Ikke-tilladt anvendelse

- Brug af produktet uden instruktion
- Brug udenfor de nævnte grænser
- Deaktivering af sikkerhedssystemer og fjernelse af forklarende og advarende mærkater
- Åbning af udstyret med værktøj (skrue-trækkere etc.)
- Modifikation eller ændring af produktet
- Brug af tilbehør fra andre producenter uden udtrykkelig godkendelse
- Bevidst blanding af tredjepart; også i mørke
- Utilstrækkelige sikkerhedsforanstaltninger på opmålingsstedet (f.eks. ved måling på veje, byggepladser etc.)
- Bevidst fejlagtig eller uansvarlig adfærd på stilladser, ved brug af stiger, ved måling nær maskiner, som kører, eller nær dele af maskiner eller installationer, som ikke er afskærmede
- Sigte direkte mod solen

### Farer ved brug

#### ADVARSEL

Vær opmærksom på fejlagtige målinger, hvis instrumentet er defekt, eller hvis det er blevet tabt eller er fejlanvendt eller modificeret. Udfør testmålinger med jævne mellemrum.

Især efter instrumentet har været udsat for anormal brug, og før, under og efter vigtige målinger.

#### FORSIGTIG

Forsøg aldrig at reparere produktet selv. I tilfælde af beskadigelse kontaktes en lokal forhandler.

#### ADVARSEL

Ændringer eller modifikationer ikke udtrykkeligt godkendt kan fratage brugeren retten til at bruge udstyret.

### Begrænsninger for brug

- Se afsnittet "Tekniske specifikationer".

Apparatet er designet til brug i områder egnet til menneskers permanente ophold. Brug ikke produktet i eksplosivt farlige områder eller i kemisk aggressive områder.

### Bortskaffelse

#### ADVARSEL

Brugte batterier må ikke smides ud med husholdningsaffaldet. Skån miljøet og tag dem til opsamlingsstederne i overensstemmelse med nationale eller lokale regler.

Produktet må ikke smides ud med husholdningsaffaldet.

Smid produktet ud i overensstemmelse med de gældende nationale regler i dit land.

Følg de nationale og landespecifikke regler.

Produktspecifik behandling og affaldshåndtering kan downloades fra vores hjemmeside.

### Elektromagnetisk kompatibilitet (EMC)

#### ADVARSEL

Apparatet lever op til de strengeste krav i de relevante standarder og regler. Alligevel kan muligheden for forstyrrelse af andre apparater ikke helt udelukkes.



## Laserklassifikation

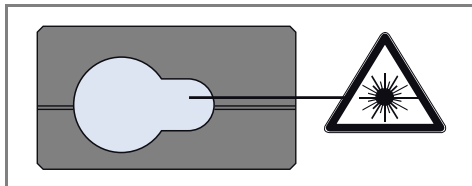

Instrumentet laver synlige laserstråler, som udsendes fra instrumentet:

Det er et klasse 2 laserprodukt i overensstemmelse med:

- IEC60825-1 : 2007 "Strålesikkerhed for laserprodukter"

**Laserklasse 2 produkter:**

Se ikke ind i laserstrålen og ret den ikke unødvendigt mod andre. Øje-beskyttelse klæres normalt med undvige reaktion incl. blinkerefleksen.

**⚠ ADVARSEL**

At se direkte ind i strålen med optiske hjælpemidler (f.eks. kikkerters, teleskoper) kan være farligt.

**⚠ FORSIGTIG**

Det kan være farligt for øjnene at se direkte ind i laserstrålen.

## Mærkning

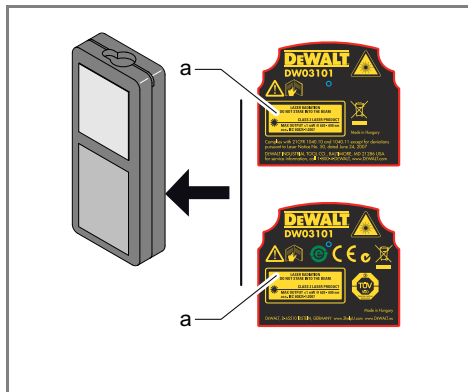

Sæt laserlabel (a) på med dit lands sprog.

# Innehåll

<b>Etablera instrument</b> .....	<b>2</b>
Introduktion- .....	2
Översikt .....	2
Display- .....	3
Lägga in batterier .....	3
<b>Funktioner</b> .....	<b>4</b>
Starta/Stänga av .....	4
Rensa .....	4
Meddelandekoder .....	4
Justera mätreferens / stativ .....	4
Multifunktionellt bakstycke .....	5
Enhet, längd inställning .....	5
Enhet, lutning inställning .....	5
Timer (automatisk utlösning) .....	5
Ljud PÅ/AV- .....	6
Belysning PÅ/AV- .....	6
<b>Mätfunktioner</b> .....	<b>7</b>
Enkel längdmätning- .....	7
Permanent / Minimum-Maximummätning- .....	7
Lägg till / Subtrahera .....	7
Area- .....	8
Volym- .....	9
Rumsvinkelfunktion .....	10
Pythagoras (2 punkter) .....	11
Pythagoras (3 punkter) .....	11
Pythagoras (delhöjd) .....	12
Utsättning .....	13
Smart horisontellt läge .....	13
Sök höjd .....	14
Nivellering .....	14
Minne (20 senaste displayer) .....	15

Radera minne .....	15
--------------------	----

## Kalibrering .....

Kalibrera lutningssensor (lutningskalibrering) .....	16
--	----

## Tekniska data .....

## Meddelandekoder .....

## Underhåll- .....

## Garanti .....

## Säkerhetsföreskrifter .....

Ansvarsområden .....	18
Tillåten användning .....	19
Förbjuden användning .....	19
Risker vid användande .....	19
Begränsningar i användande .....	19
Avfallshantering .....	19
Elektromagnetisk acceptans EMV .....	19
Laserklassificering .....	20
Produktetikettering .....	20

## Introduktion

 Läs igenom säkerhetsanvisningar och handbok noga innan du använder instrumentet första gången.

 Personal med instrumentansvar måste försäkra sig om att alla användare förstår och följer dessa föreskrifter.

Symbolerna har följande innebörd:

### VARNING

Indikerar en potentiellt farlig situation vilken, om den inte undviks, kan resultera i svåra skador för användaren eller användarens död.

### OBSERVERA

Indikerar en potentiellt farlig situation vilken, om den inte undviks, kan resultera i mindre skador för användaren, men avsevärd materiell och finansiell skada samt miljömässig påverkan.

**i** Viktiga avsnitt, som bör följas vid praktisk hantering, därför att de möjliggör att instrumentet används på ett tekniskt korrekt och effektivt sätt.

## Översikt

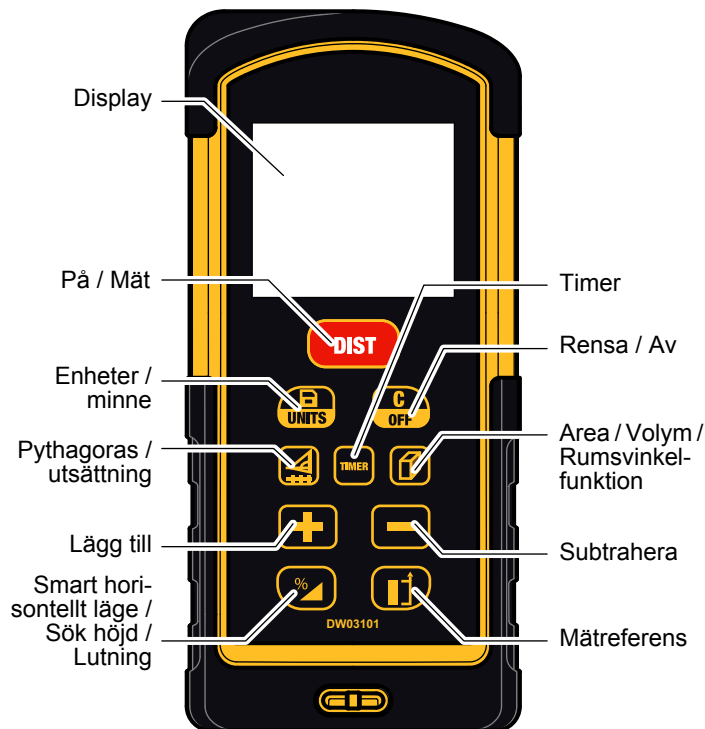

## Display

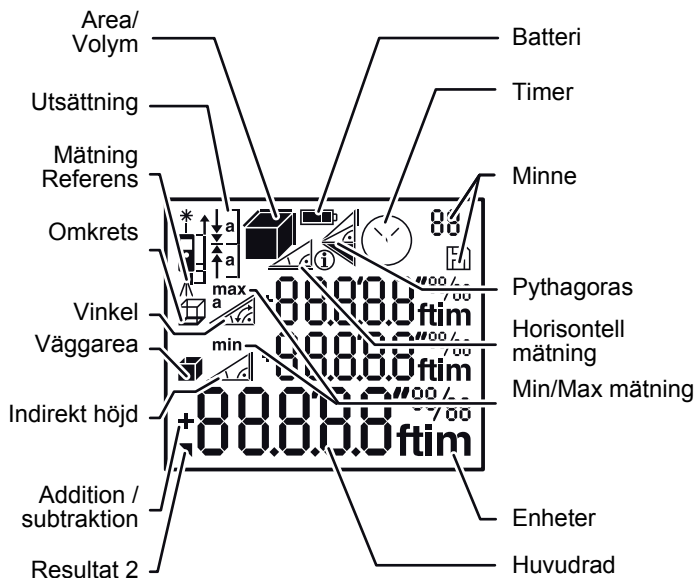

## Lägga in batterier

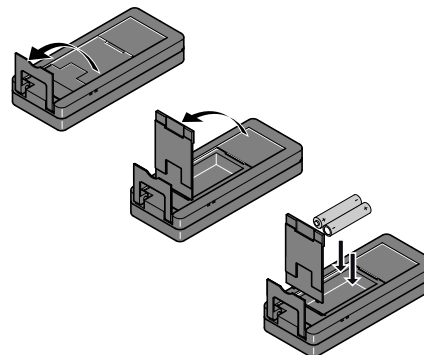

i

Använd inte zinkbatterier för att säkra pålitlig användning. Byt batterier när batterisymbolen blinkar.

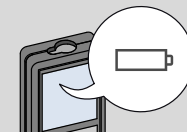

**Starta/Stänga av**

Instrumentet är avstängt.

i

Tryck PÅ-tangenten 2 sek för att starta kontinuerligt laserläge. Instrumentet stänger av automatiskt om ingen tangent trycks inom 180 sek.

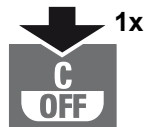
**Rensa**

Ångra senaste funktion.

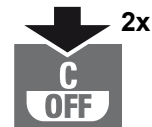

Lämna aktuell funktion, gå till standardläge.

**Meddelandekoder**

Om infoikonen visas med ett nummer, se instruktionerna i avsnitt "Meddelandekoder". Exempel:

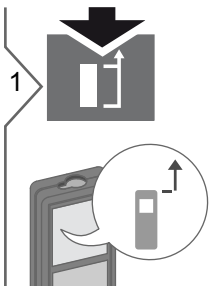
**Justera mätreferens / stativ**

Avståndet mäts från instrumentets framsida.

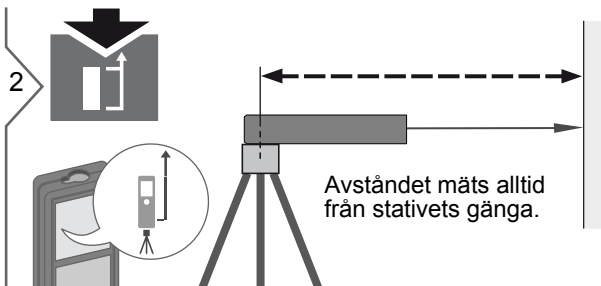

Avståndet mäts alltid från stativets gänga.

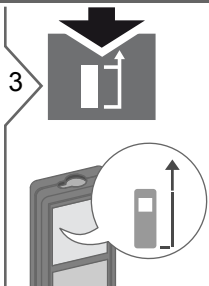

Avståndet mäts från instrumentets baksida (standardinställning).

## Funktioner

### Multifunktionellt bakstycke

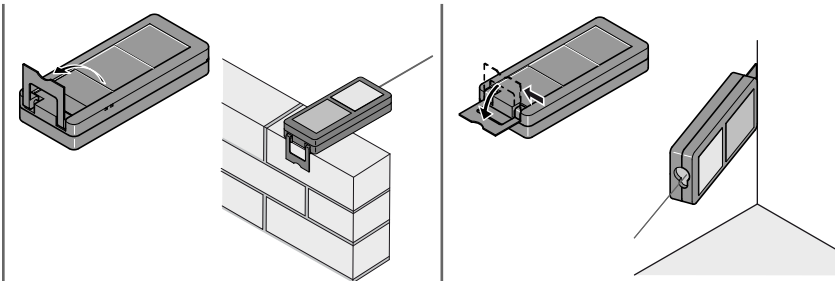

**i** Bakstyckets orientering känns av automatiskt och nollpunkten justeras motsvarande.

### Enhet, längd inställning



2 sek

Växla mellan olika enheter:

0.000 m	0.00 ft
0.0000 m	0'00" 1/32
0.00 m	0.00 in
	0 in 1/32

### Enhet, lutning inställning



2 sek samtidigt

Växla mellan olika enheter:

180 °
0.0 %

### Timer (automatisk utlösning)

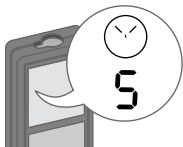

Justera fördröjning för automatisk utlösning (max. 60 sek, standardinställning 5 sek)

**i** Sekunderna räknar ner till mätningen när tangenten släpps med aktiv laser. Fördröjd utlösning rekommenderas för exakt inriktning, t.ex. vid långa avstånd. Det undviker att instrumentet skakar när man trycker på mätknappen.

## Funktioner

## Ljud PÅ/AV



2 sek samtidigt

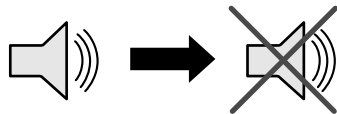

## Belysning PÅ/AV



2 sek samtidigt

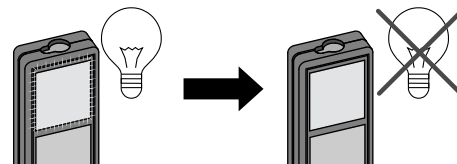

## Mätfunktioner

### Enkel längdmätning

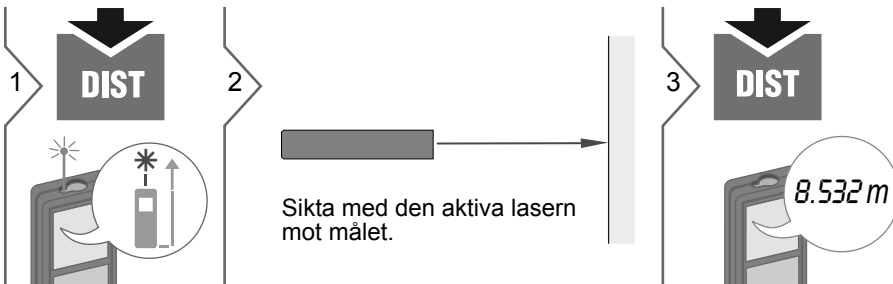

**i** Mätbara ytor: Mätfel kan uppstå vid mätning mot färglösa vätskor, glasskivor, styropor eller liknande ljusgenomsläpande ytor eller mot högljudda ytor. Mättiden ökar mot mörka ytor.

### Permanent / Minimum-Maximummätning

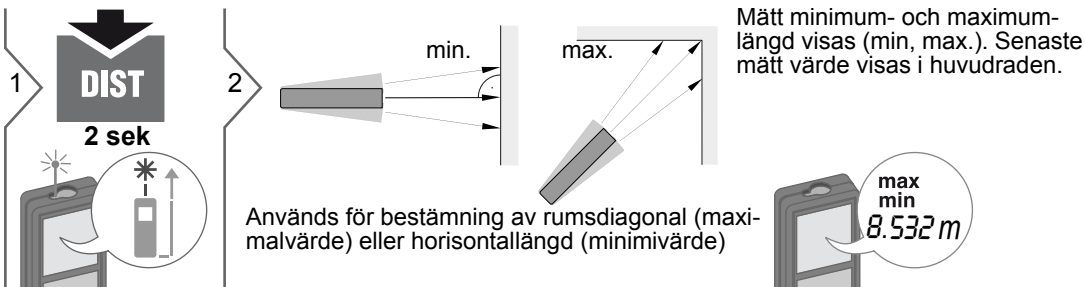

Stoppar permanent / minimum-maximummätning.

### Lägg till / Subtrahera

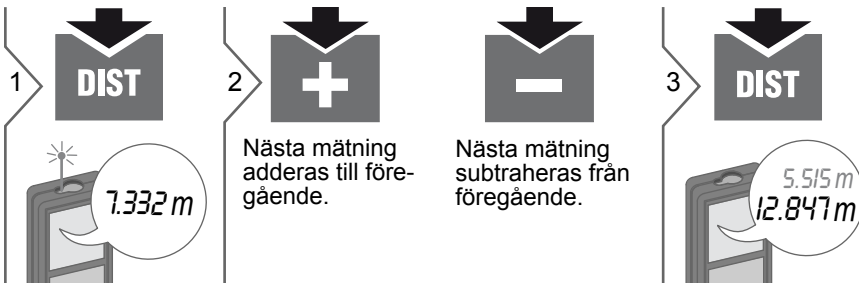

**i** Resultatet visas i huvudraden och uppmätt värde ovanför. Upprepa detta vid behov. Samma tillvägagångssätt kan användas för att lägga till eller subtrahera areor eller volymer.

**Area**

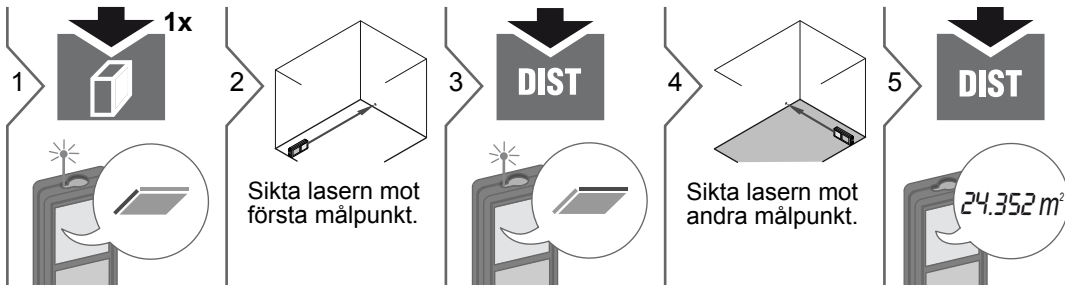

**i** Resultatet visas i huvudraden och uppmätt värde ovanför.

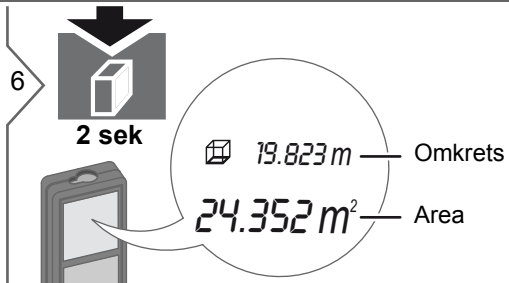



## Rumsvinkelfunktion

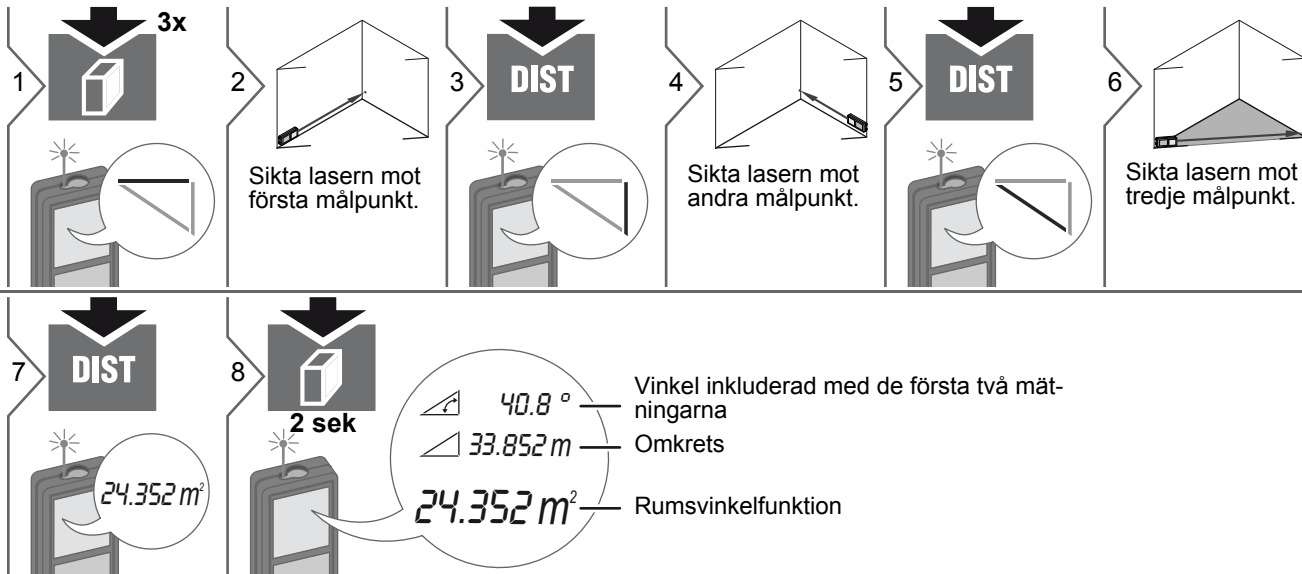

## Mätfunktioner

### Pythagoras (2 punkter)

1  1x

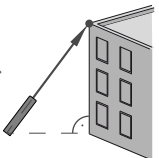
2  Sikta lasern mot övre punkt.

3  DIST

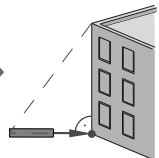
4  Sikta lasern vinkelrätt mot lägre punkt.

5  DIST

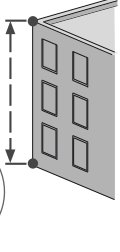
 8.294 m

**i** Resultatet visas i huvudraden och uppmätt längd ovanför. Tryck mättangenten 2 sek i denna funktion för att aktivera minimum eller maximummätning automatiskt.

### Pythagoras (3 punkter)

1  2x

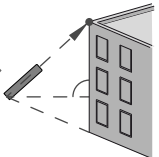
2  Sikta lasern mot övre punkt.

3  DIST

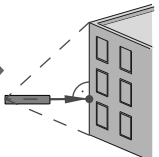
4  Sikta lasern mot vinkelrät punkt.

5  DIST

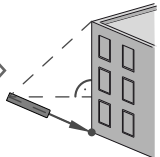
6  Sikta lasern mot lägre punkt.

7  DIST

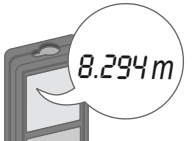
 8.294 m

**i** Resultatet visas i huvudraden och uppmätt längd ovanför. Tryck mättangenten 2 sek i denna funktion för att aktivera minimum eller maximummätning automatiskt.

# Mätfunktioner

## Pythagoras (delhöjd)

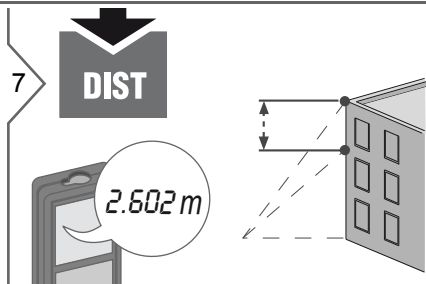
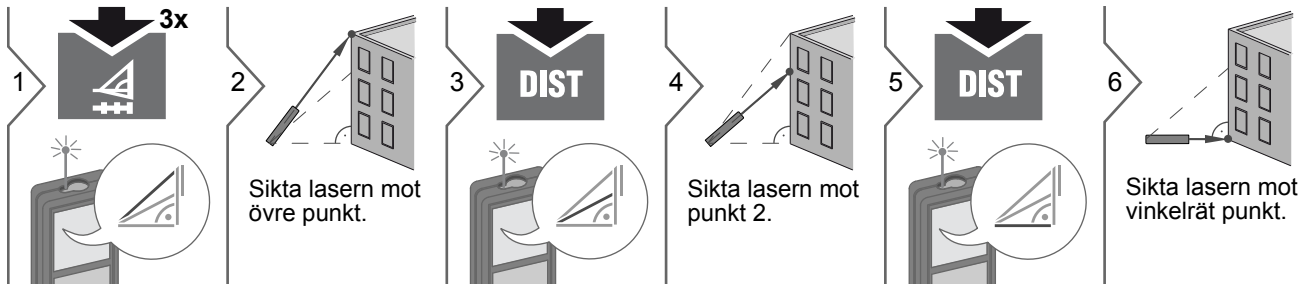

**i** Resultatet visas i huvudraden och uppmätt längd ovanför. Tryck mättangenten 2 sek i denna funktion för att aktivera minimum eller maximummätning automatiskt.

# Mätfunktioner

## Utsättning

**1** **4x**

**2** Justera värde.

**3** **DIST**

Acceptera värdet och starta mätning.

**4**

Flytta instrumentet långsamt längs utsättningslinjen. Avståndet till nästa utsättningspunkt visas.

$0.625\text{ m}$

$1.000\text{ m}$

$0.625\text{ m}$

$0.240\text{ m}$

$0.625\text{ m}$

$0.240\text{ m}$

**i** Instrumentet piper när man närmar sig en utsättningspunkt med mindre än 0.1 m. Funktionen kan stoppas RENZA/AV-tangenten.

## Smart horisontellt läge

**1** **1x**

**2** Sikta med lasern mot målet.

**3** **DIST**

$24.3^\circ$  —  $\alpha$

$0.032\text{ m}$  —  $y$

$4.827\text{ m}$  —  $z$

**i** Tryck tangenten igen för att inaktivera horisontell mätning.

(upp till  $360^\circ$  och tvärlutning på  $\pm 10^\circ$ )

**Sök höjd**

Denna funktion visar sökhöjden kontinuerligt om instrumentet är startat på ett stativ. Avståndsmätning nr 2 behövs inte eftersom vinkeln mäts automatiskt.

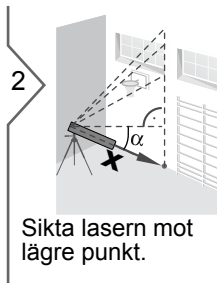
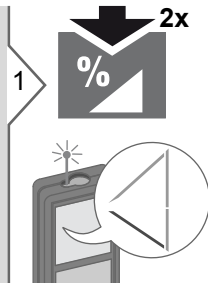

Rikta lasern mot de övre punkterna och vinkeln/ höjdsökning-  
en startar automatiskt.

5

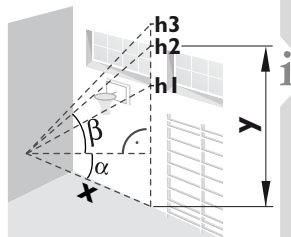
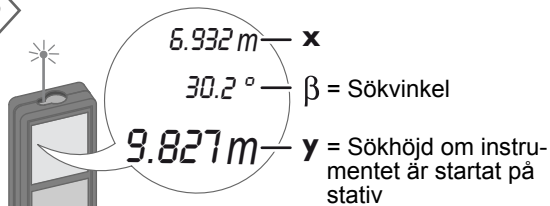

Den sökta höjden " $y$ " är i 90° vinkel till första siktpunkt " $x$ ".

6



Stoppar höjdsökningen och visar senaste mätning.

**Nivellering**

Denna funktion visar kontinuerligt instrumentets lutning. Instrumentet piper vid en lutning på  $\pm 5^\circ$ . Det piper snabbare ju närmare det kommer mot  $0^\circ$ . Instrumentet piper kontinuerligt vid en lutning på  $\pm 0.3^\circ$ .

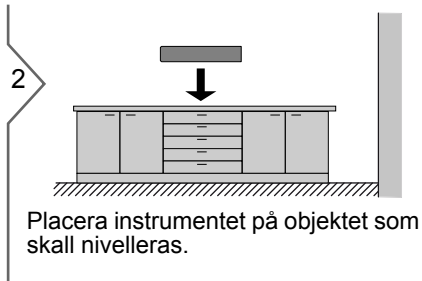
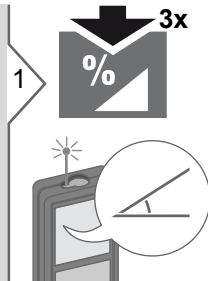

Lutningen visas (räckvidd  $\pm 180^\circ$ ).

## Mätfunktioner

### Minne (20 senaste displayer)



1



20 senaste displayer visas.



2

Bläddra genom de 20 senaste displayerna.

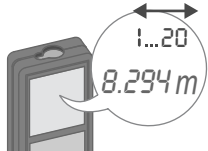

3



**2 sek**

Värdet i huvudraden kan användas för ytterligare beräkningar.

### Radera minne

3





**2 sek samtidigt**

Minnet är helt raderat.

# Kalibrering

## Kalibrera lutningssensor (lutningskalibrering)

1  **2 sek samtidigt**

 MEAS 1  
HOR  
CAL

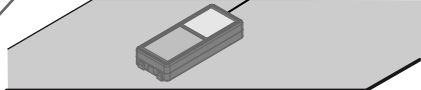
2  Placera instrumentet på en absolut plan yta.

3  **DIST**

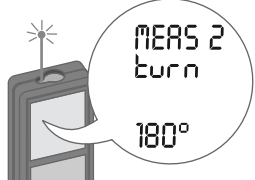
 MEAS 2  
turn  
180°

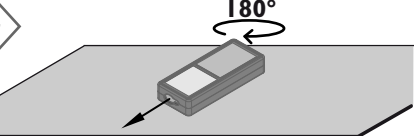
4  180°  
Vrid instrumentet horisontellt 180° och placera det på en absolut plan yta igen.

5  **DIST**

 MEAS 3  
VER  
CAL

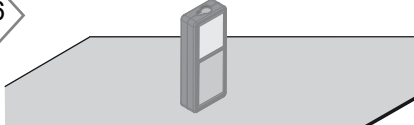
6  Vrid instrumentet upp och ner och placera det på en absolut plan yta igen.

7  **DIST**

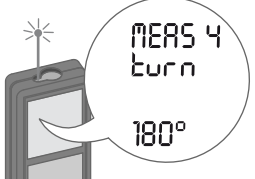
 MEAS 4  
turn  
180°

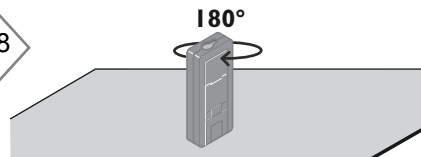
8  180°  
Vrid instrumentet horisontellt 180° och placera det på en absolut plan yta igen.

9  **DIST**

 OK  
CAL

 Instrumentet återgår till normalt läge efter 2 sek.

Avståndsmätning	
Typisk mättolerans *	± 1,0 mm / 0,04 in ***
Maximal mättolerans**	± 2,0 mm / 0,08 in ***
Målplattans räckvidd	100 m / 330 ft
Typisk räckvidd*	80 m / 262 ft
Räckvidd vid ogyynnsamma förhållanden **** 60 m	60 m / 197 ft
Minsta displayenhet	0.1 mm / 1/32 in
Ø Laserpunkt i längder	6 / 30 / 60 mm (10 / 50 / 100 m)
Lutningsmätning	
Mättolerans mot laserstråle*****	± 0.2°
Mättolerans mot hus*****	± 0.2°
Räckvidd	360°
Allmänt	
Laserklass	2
Lasertyp	635 nm, < 1 mW
Stråldivergens	0.16 x 0.6 mrad
Impulstid	0.2 x 10 <sup>-9</sup> s - 0.8 x 10 <sup>-9</sup> s
Skyddsklass	IP54 (dammskyddad, stänkvattenskyddad)
Auto. avstängn. laser	efter 90 s
Auto. avstängn. instrument	efter 180 s
Batteritid (2 x AAA)	upp till 5000 mätningar
Mått (H x D x B)	125.2 x 58 x 32.6 mm 4.9 x 2,3 x 1.3 in
Vikt (inkl. batterier)	154 g / 5.43 oz
Temperaturområde:	
- Förvaring	-25 till 70 °C -13 till 158 °F
- Drift	-10 till 50 °C 14 till 122 °F

\* gäller för 100 % reflekterande yta (vitmålad vägg), dålig bakgrundsbelysning, 25 °C

\*\* gäller för 10 till 500 % reflekterande yta, mycket bakgrundsbelysning, - 10 °C till + 50 °C

\*\*\* Tolerans gäller från 0.05 m till 10 m med noggrannhetsnivå 95%. Maximal tolerans kan sjunka till 0,1 mm/m mellan 10 m till 30 m och till 0.2 mm/m vid avstånd över 30 m

\*\*\*\* gäller för 100 % reflekterande yta, bakgrundsbelysning ca 30'000 lux

\*\*\*\*\* efter användarkalibrering. Ytterligare vinkelavvikelse på +/- 0.01° per grad upp till +/-45° i varje kvadrant. Gäller vid rumstemperatur. Den maximala avvikelsen ökar med +/- 0.1° för hela driftstemperaturen.

i Använd ett stativ för noggranna indirekta resultat. Tvärlutning bör undvikas för noggranna lutningsmätningar.

Funktioner	
Längdmätning	Ja
Min/Max mätning	Ja
Permanent mätning	Ja
Utsättning	Ja
Addition/Subtraktion	Ja
Area	Ja
Volym	Ja
Pythagoras	2-punkt, 3-punkt, delhöjd
Smart horisontellt läge / Indirekt höjd	Ja
Sök höjd	Ja
Nivellering	Ja
Minne	20 displayer
Ljud	Ja
Belyst display	Ja
Multifunktionellt bakstycke	Ja

## Meddelandekoder

Kontakta återförsäljaren om meddelandet **Error** inte visas när instrumentet har startats upprepade gånger.

Om meddelandet **InFo** visas med ett nummer, tryck Rensa-tangenten och följ instruktionerna:

Nr.	Orsak	Åtgärd
156	Tvårlutning över 10°	Håll instrumentet utan tvårlutning.
162	Kalibreringsfel	Kontrollera att instrumentet är placerat på en absolut horisontell och plan yta. Upprepa kalibreringen. Om felet fortfarande kvarstår, kontakta återförsäljaren.
204	Fel i beräkningen	Gör om mätningen.
252	För hög temperatur	Låt instrumentet svalna.
253	För låg temperatur	Värm instrumentet.
255	Mottagen signal för svag, mättid för lång	Byt målyta (t.ex. vitt papper).
256	Mottagen signal för stark	Byt målyta (t.ex. vitt papper).
257	För mycket bakgrundsljus	Skugga målytan.
258	Mätning utanför mätträckvidd	Justera räckvidd.
260	Laserstråle bruten	Upprepa mätning.

## Underhåll

- Rengör instrumentet med mjuk fuktig duk.
- Doppa inte instrumentet i vatten.
- Använd inga aggressiva rengöringsmedel eller lösningsmedel.

## Garanti

### Europa:

- 30 dagar utan risk garanterat tillfredsställd
- Ett års gratis service
- Ett års full garanti

Mer information finns på internet [www.2helpU.com](http://www.2helpU.com).

### Nordamerika:

- Tre års begränsad garanti
- Ett års gratis service
- Pengar tillbaka inom 90 dagar

Mer information finns på internet [www.dewalt.com](http://www.dewalt.com).

## Säkerhetsföreskrifter

Personal med instrumentansvar måste försäkra sig om att alla användare förstår och följer dessa föreskrifter.

### Ansvarsområden

#### Ansvarsområde för tillverkare av originalutrustning:

Europa:

DEWALT

D-65510 Idstein, Germany

[www.2helpU.com](http://www.2helpU.com)

[www.dewalt.eu](http://www.dewalt.eu)

Nordamerika:

DEWALT Industrial Tool Co.

Baltimore, MD21286, USA

För service kontakta 1-800-4-DEWALT.

[www.dewalt.com](http://www.dewalt.com)

Ovanstående företag är ansvarig för att leverans av instrumentet, inklusive handbok, sker i ett totalt säkert tillstånd. Ovanstående företag är inte ansvarig för tillbehör från annan tillverkare.

#### Instrumentansvariges åligganden:

- Att förstå säkerhetsinstruktionerna för instrumentet och instruktionerna i handboken.
- Att känna till lokala säkerhets- och arbetarskyddsföreskrifter.
- Se alltid till att obehöriga inte får tillgång till instrumentet.

## Säkerhetsföreskrifter

### Tillåten användning

- Mätning av avstånd
- Lutningsmätning

### Förbjuden användning

- Användning av instrumentet utan instruktioner
- Användning utanför angivna gränser
- Inaktivering av säkerhetssystem och eliminering av förklarande text eller varningsetiketter
- Öppna instrumentet med hjälp av verktyg (t.ex. skruvmejsel)
- Modifiering eller konvertering av instrumentet
- Användning av tillbehör från annan tillverkare utan medgivande.
- Medvetet blända annan person, även i mörker
- Otillräckliga förebyggande säkerhetsanordningar vid uppställning av instrument (t ex vid mätningar av vägar eller byggnadsplatser)
- Medvetet eller oansvarig hantering på byggnadsställningar vid användning av stege när mätning pågår i närheten av drifttaga maskiner eller nära oskyddade maskiner eller installationer
- Direkt inriktning mot solen

### Risker vid användande

#### VARNING

Se upp för felaktiga mätningar om ett defekt instrument används, efter ett fall eller andra otillåtna påfrestningar resp. förändringar av instrumentet. Utför periodiska kontrollmätningar.

Särskilt efter onormal påfrestning och före/efter viktiga mätningar.

#### OBSERVERA

Försök inte själv att reparera instrumentet. Vänligen kontakta din återförsäljare vid defekt instrument.

#### VARNING

Ändringar och modifikationer, utan användarens uttryckliga tillstånd, kan inskränka användarens rätt att använda instrumentet.

#### Begränsningar i användande

- Se kapitel Tekniska data.
  - Instrumentet är anpassat för användning i miljö lämpad för människor.
- Använd inte instrumentet i aggressiv eller explosiv miljö.

### Avfallshantering

#### OBSERVERA

Tomma batterier får inte avfallshandteras som hushållssopor. Tänk på miljön och lämna in batterierna till närmaste återvinningsstation enligt gällande miljölagstiftning.

Instrumentet får inte avfallshandteras som hushållssopor.

Se till att instrumentet skrotas på ett sådant sätt att nationella regler efterlevs.

Följ nationella och landsspecifika regler.

Information om avfallshantering kan laddas hem från vår hemsida.



### Elektromagnetisk acceptans EMV

#### VARNING

Instrumentet uppfyller kraven för gällande regler och normer.

Möjligheten för inverkan på annan utrustning kan trots detta inte uteslutas.

### Laserklassificering

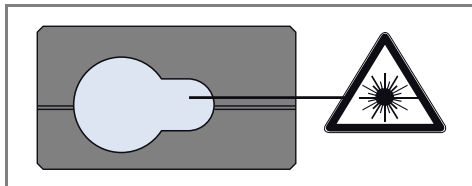

Instrumentet genererar en synlig laserstråle utgående från instrumentet:

Instrumentet motsvarar laserklass 2 enligt:

- IEC60825-1 : 2007 Lasersäkerhet

### Laserklass 2 produkter:

Titta inte in i laserstrålen och rikta den inte mot andra personer i onödan. Skydd av ögat uppstår normalt genom bortvändningsreaktioner och blinkreflexen.

### **VARNING**

Det kan vara farligt att titta in i strålen med ett optiskt instrument t.ex. kikare, teleskop.

### **OBSERVERA**

Titta inte in i laserstrålen, det kan vara farligt för ögonen.

### Produktetikettering

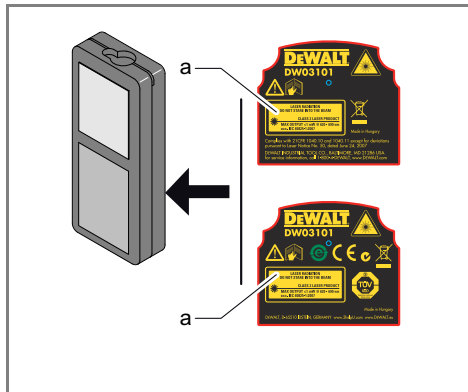

Applicera laseretiketten (a) för ditt språk.

# Sisällysluettelo

<b>Laitteen asennus</b> .....	<b>2</b>
Johdanto .....	2
Yleiskuva .....	2
Näyttö .....	3
Paristojen asettaminen .....	3
<b>Toiminnot</b> .....	<b>4</b>
Kytkeminen PÄÄLLE/POIS .....	4
Tyhjennä .....	4
Viestikoodit .....	4
Mittatason asettaminen / kolmijalka .....	4
Monikäyttöinen päätykappale .....	5
Etäisyyden yksikön asetus .....	5
Kaltevuuden yksikön asetus .....	5
Ajastin (automaattinen vapautus) .....	5
Piippaus PÄÄLLE/POIS .....	6
Valaistus PÄÄLLE/POIS .....	6
<b>Mittaustoiminnot</b> .....	<b>7</b>
Yksittäinen etäisyyden mittaus .....	7
Jatkuva / Minimi-maksimi -mittaus .....	7
Laske yhteen / Vähennä .....	7
Ala .....	8
Tilavuus .....	9
Kolmion ala .....	10
Pythagoras (2-pisteinen) .....	11
Pythagoras (3-pisteinen) .....	11
Pythagoras (osittainen korkeus) .....	12
Paalutus .....	13
Älykäs vaakatila .....	13
Korkeuden jäljittäminen .....	14
Tasaus .....	14
Muistin (20 viimeisintä tulosta) .....	15

Muistin tyhjennys .....

15

## **Kalibrointi** .....

16

Kaltevuusanturin kalibrointi (Kallistuksen kalibrointi) .....

16

## **Tekniset tiedot** .....

17

## **Viestikoodit** .....

18

## **Huolto** .....

18

## **Takuu** .....

18

## **Turvallisuusohjeet** .....

18

Vastuualueet .....

18

Sallittu käyttö .....

19

Kielletty käyttö .....

19

Käyttöön liittyvät vaarat .....

19

Käytön rajoitukset .....

19

Hävittäminen .....

19

Sähkömagneettinen yhteensopivuus (EMC) .....

19

Laserluokitus .....

20

Merkinnät .....

20

**Johdanto**

 Turvallisuusohjeet ja käyttöohje tulee lukea läpi huolellisesti ennen tuotteen käyttämistä ensimmäistä kertaa.

 Tuotteen vastuuhenkilön on varmistettava, että kaikki käyttäjät ymmärtävät nämä ohjeet ja noudattavat niitä.

Käytetyillä symboleilla on seuraavat merkitykset:

 **VAROITUS**

Merkitsee mahdollista vaaratilannetta tai käyttötarkoituksen vastaista käyttöä, joka voi johtaa kuolemaan tai vakavaan loukkaantumiseen, ellei sitä vältetä.

 **HUOMIO**

Merkitsee mahdollista vaaratilannetta tai käyttötarkoituksen vastaista käyttöä, joka voi johtaa lieviin henkilövahinkoihin ja/tai huomattaviin vahinkoihin esineille, omaisuudelle tai ympäristölle.

**i** Tärkeitä kappaleita, joita on noudatettava käytännössä, koska ne mahdollistavat kojeen teknisesti oikean ja tehokkaan käytön.

**Yleiskuva**



## Näyttö

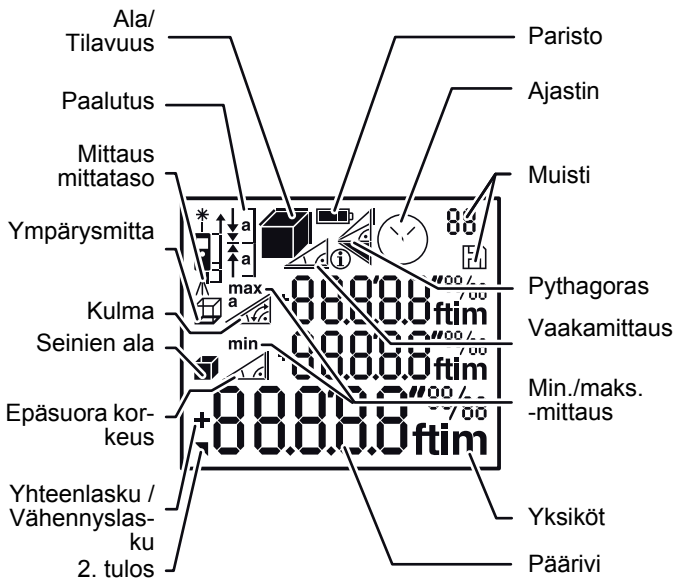

## Paristojen asettaminen

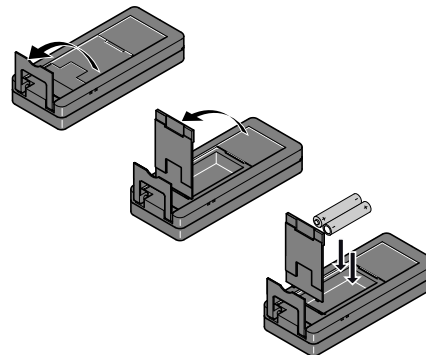

i

Luotettavan käytön varmistamiseksi älä käytä sinkki-hiili-paristoja. Vaihda paristot, kun paristosymboli vilkkuu.

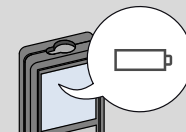

### Kytkeminen PÄÄLLE/POIS



**i** Paina PÄÄLLE-painiketta 2 s käynnistääkseen jatkuvan lasertilan. Jos mitään näppäintä ei paineta 180 sekuntiin, laite kytkeytyy automaattisesti pois päältä.

### Tyhjennä

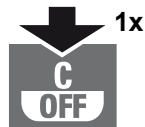

Kumoa viimeinen toiminto.

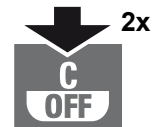

Poistu varsinaisesta toiminnosta, siirry oletuskäyttötilaan.

### Viestikoodit

Jos tietokuvake ilmestyy numeron kanssa, noudata osiossa "Viestikoodit" olevia ohjeita. Esimerkki:



### Mittatason asettaminen / kolmijalka

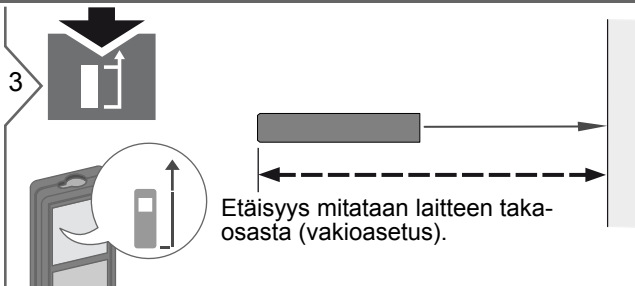
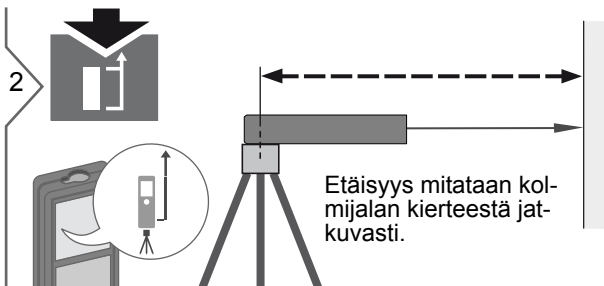
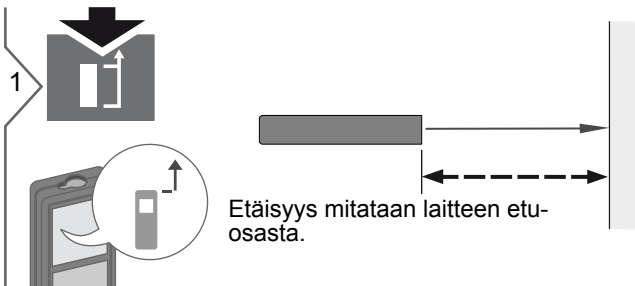

## Toiminnot

### Monikäyttöinen päätykappale

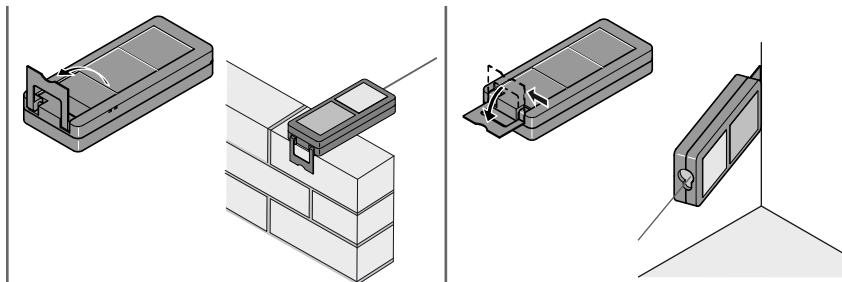

**i** Päätykappaleen asento havaitaan automaattisesti ja nollapiste säädetään sen mukaisesti.

### Etäisyyden yksikön asetus



2 s

Vaihtaminen seuraavien yksiköiden välillä:

0.000 m	0.00 ft
0.0000 m	0'00" 1/32
0.00 m	0.00 in
	0 in 1/32

### Kaltevuuden yksikön asetus



2 s samanaikaisesti

Vaihtaminen seuraavien yksiköiden välillä:

180 °
0.0 %

### Ajastin (automaattinen vapautus)

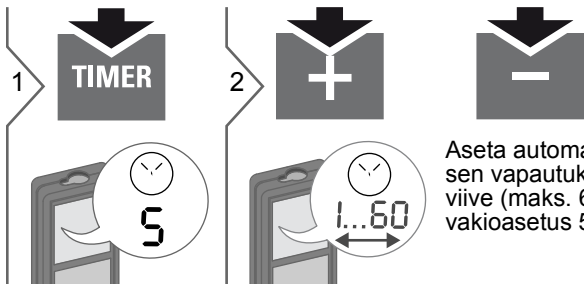

Aseta automaattisen vapautuksen viive (maks. 60 s vakioasetus 5 s)

**i** Heti kun näppäin on vapautettu aktiivisella laserilla, jäljellä olevat sekunnit mittaukseen saakka näytetään alaslaskennassa. Viivästetty vapautus on suositeltavaa tarkkaan suuntaukseen esim. pitkissä mittauksissa. Se välttää laitteen tärinän, kun painetaan mittausnäppäintä.

**Toiminnot****Piippaus PÄÄLLE/POIS**

2 s samanaikai-  
sesti

**Valaistus PÄÄLLE/POIS**

2 s samanaikai-  
sesti

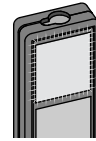

## Mittaustoiminnot

### Yksittäinen etäisyyden mittaus

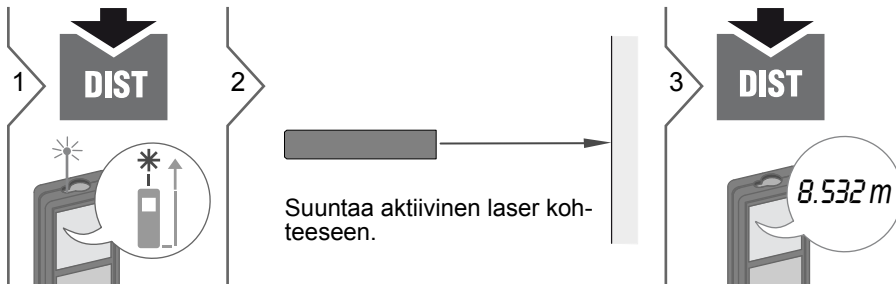

i

Kohdepinnat: Mittausvirheitä voi ilmetä mitattaessa väröttömiin nesteisiin, lasiin, vaahtomuoviin tai puolilämpäiseviin pintoihin tai suunnattaessa runsaskiiltoisiin pintoihin. Tummia pintoja vasten mitattaessa mittausaika pitenee.

### Jatkuva / Minimi-maksimi -mittaus

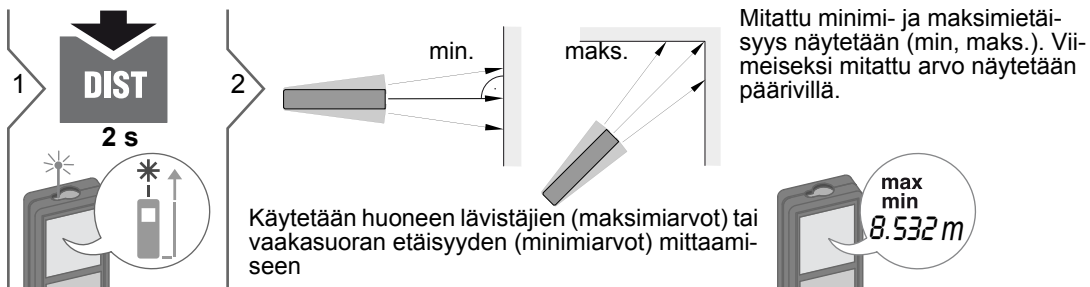

3



Pysäyttää jatkuvan / Minimi-maksimi -mittauksen.

### Laske yhteen / Vähennä

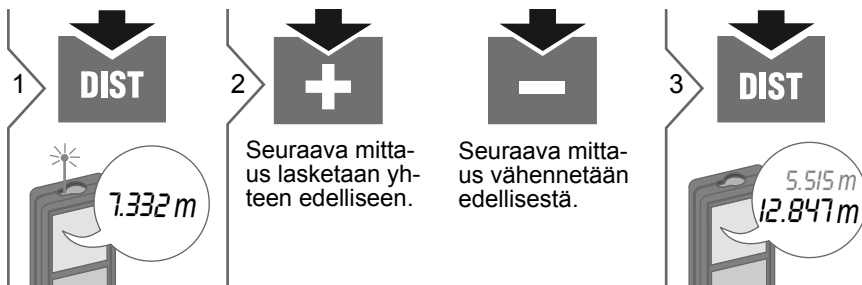

i

Tulos näytetään päälinjalla ja mitattu arvo yläpuolella. Tämä prosessi voidaan toistaa tarpeen mukaan. Samaa prosessia voidaan käyttää alojen tai tilavuuksien yhteenlaskemiseen tai vähentämiseen.

Ala

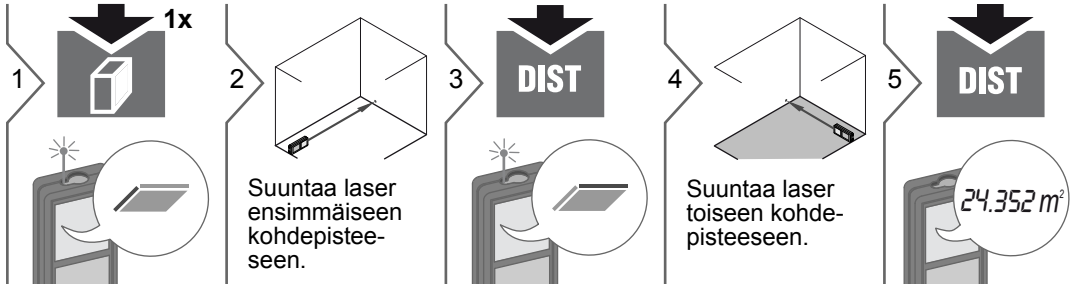

**i** Tulos näytetään päälinjalla ja mitattu arvo yläpuolella.

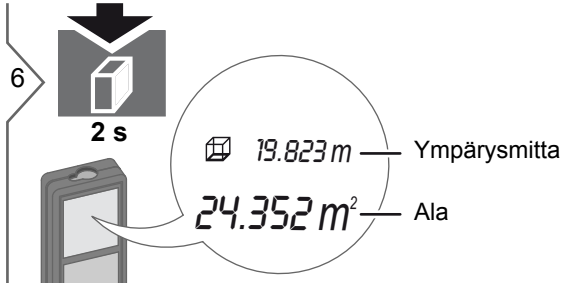

## Tilavuus

1 **2x**

2 Suuntaa laser ensimmäiseen kohdepisteeseen.

3 **DIST**

4 Suuntaa laser toiseen kohdepisteeseen.

5 **DIST**

6 Suuntaa laser kolmanteen kohdepisteeseen.

7 **DIST**

8 **2 s**

**i** Tulos näytetään päälinjalla ja mitattu arvo yläpuolella.

78.694 m<sup>3</sup>

80.208 m — Ympärysmitta

208.703 m<sup>2</sup> — Seinien ala

78.694 m<sup>3</sup> — Tilavuus

### Kolmion ala

1  **3x**

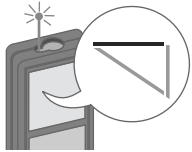

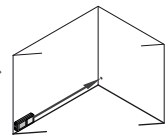
2 

Suuntaa laser ensimmäiseen kohdepisteeseen.

3  **DIST**

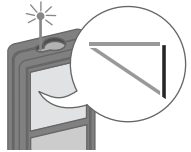

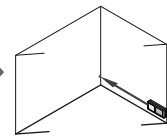
4 

Suuntaa laser toiseen kohdepisteeseen.

5  **DIST**

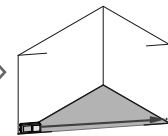

6 



Suuntaa laser kolmanteen kohdepisteeseen.

7  **DIST**

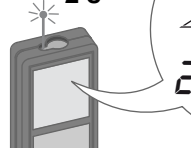

*24.352 m<sup>2</sup>*

8  **2 s**





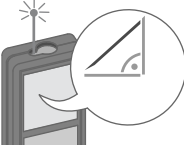

- $40.8^\circ$  — Kahden ensimmäisen mittauksen välinen kulma
- $33.852\text{ m}$  — Ympärysmitta
- $24.352\text{ m}^2$  — Kolmion ala

## Mittaustoiminnot

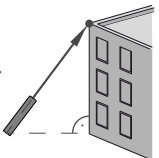
### Pythagoras (2-pisteinen)

1   Suuntaa laser yläpisteeseen.

2  Suuntaa laser suorakulmaisesti alapisteeseen.

3   Suuntaa laser suorakulmaisesti alapisteeseen.

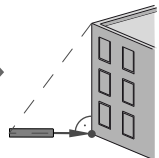
4  Suuntaa laser suorakulmaisesti alapisteeseen.

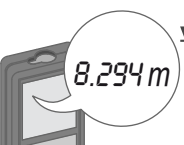
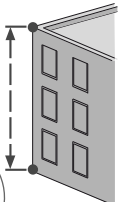
5    **i** Tulos näytetään päärivillä ja mitattu etäisyys yläpuolella. Mittausnäppäimen painaminen 2 sekunnin ajan toiminnossa aktivoi automaattisesti Minimi- tai Maksimimittauksen.

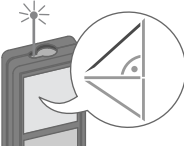

### Pythagoras (3-pisteinen)

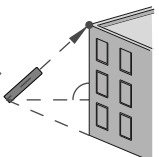
1   Suuntaa laser yläpisteeseen.

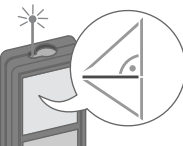
2  Suuntaa laser suorakulmaiseen pisteeseen.

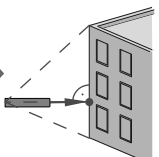
3   Suuntaa laser suorakulmaiseen pisteeseen.

4  Suuntaa laser suorakulmaiseen pisteeseen.

5   Suuntaa laser alapisteeseen.

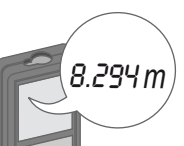
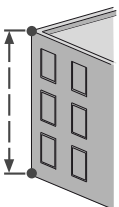
7    **i** Tulos näytetään päärivillä ja mitattu etäisyys yläpuolella. Mittausnäppäimen painaminen 2 sekunnin ajan toiminnossa aktivoi automaattisesti Minimi- tai Maksimimittauksen.

### Pythagoras (osittainen korkeus)

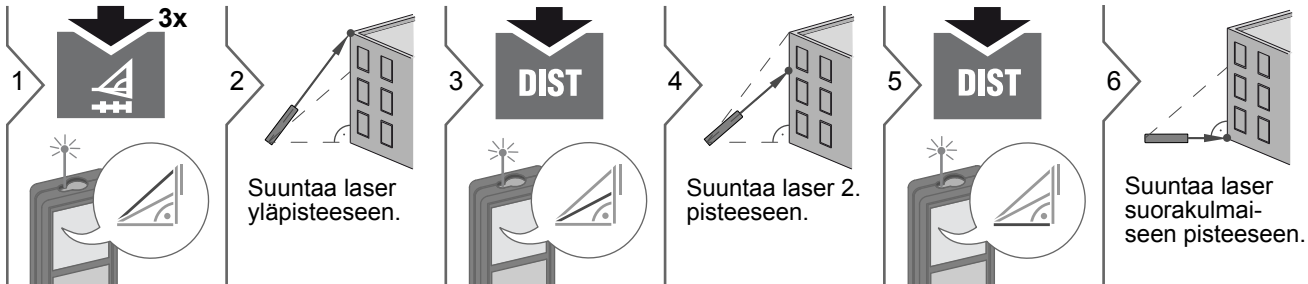

**i** Tulos näytetään päärivillä ja mitattu etäisyys yläpuolella. Mittausnäppäimen painaminen 2 sekunnin ajan toiminnossa aktivoi automaattisesti Minimi- tai Maksimimittauksen.

# Mittaustoiminnot

## Paalutus

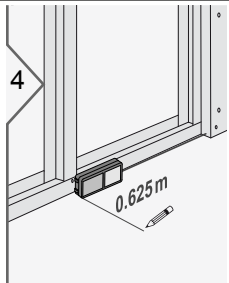
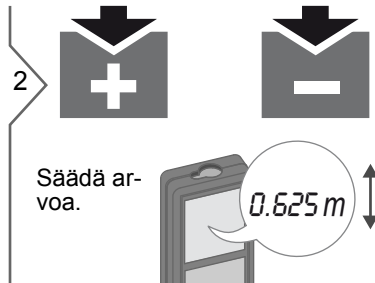
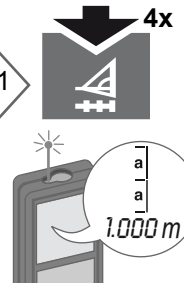
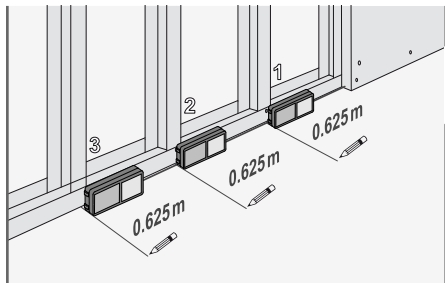

Siirrä laitetta hitaasti merkintälinjaa pitkin. Etäisyys seuraavaan merkintäpisteeseen näytetään.

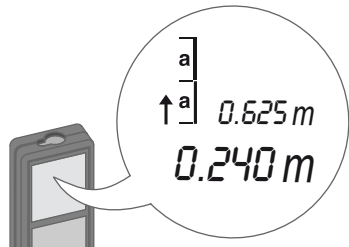

0,240 m puuttuu seuraavasta 0,625 m:n etäisyydestä.

**i** Merkintäpistettä lähestyttäessä alle 0,1 m:n etäisyydeltä koje alkaa piipata. Toiminto voidaan pysäyttää painamalla Tyhjennys/POIS-painiketta.

## Älykäs vaakatila

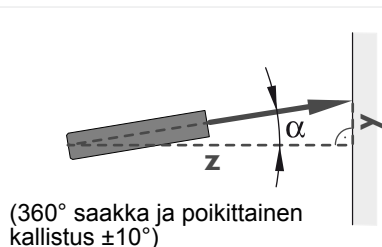
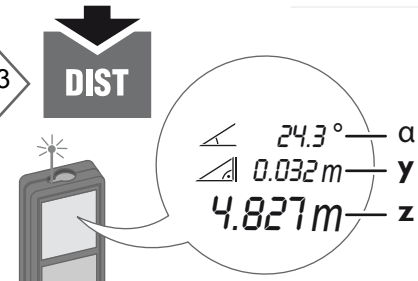
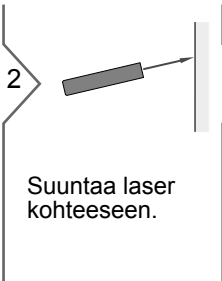
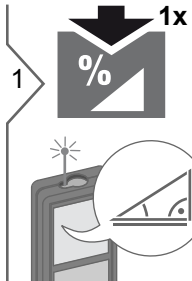

**i** Paina näppäintä uudelleen vaakamittauksen pois kytkemiseksi.

## Korkeuden jäljittäminen

**i** Tämä toiminto näyttää jatkuvasti jäljittämiskorkeuden, jos laite on kytketty päälle kolmijalalla. 2. mitausta ei tarvita, koska vain kulma mitataan automaattisesti.

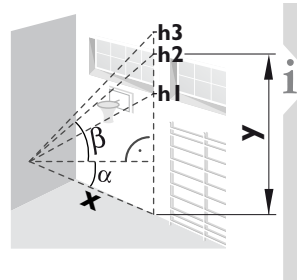
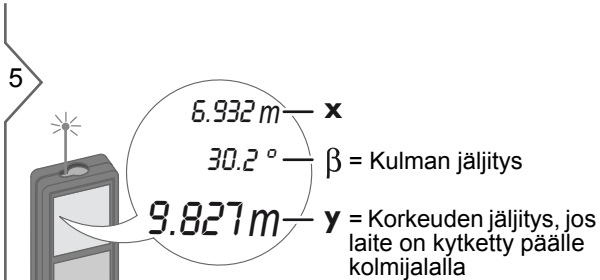
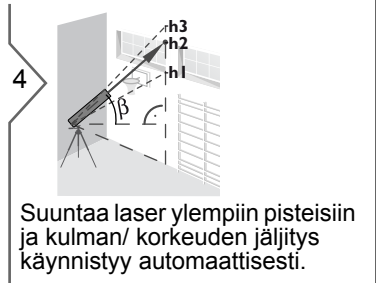
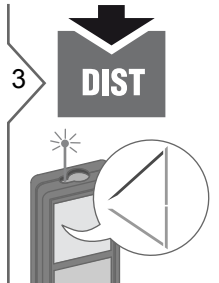
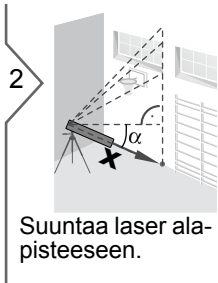
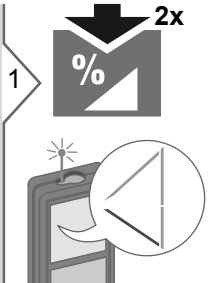

**i** Jäljitetty korkeus "y" on 90°:ssa 1.:een suunnattuun pisteeseen "x".



## Tasaus

**i** Tämä toiminto näyttää jatkuvasti laitteen inkliinaation. ±5°:n inkliinaatiosta laite käynnistää tiheästi tapahtuvan piippauksen. Mitä enemmän se poikkeaa 0°:sta, sitä nopeammin se piippaa. Jos ±0,3°:n inkliinaatio on saavutettu, laite piippaa jatkuvasti.

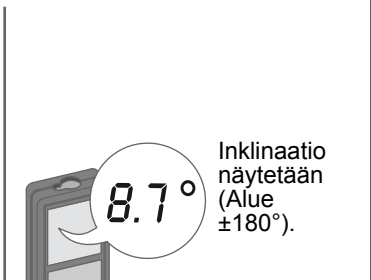
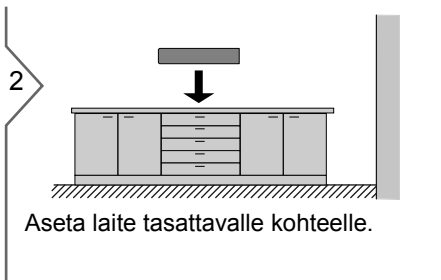
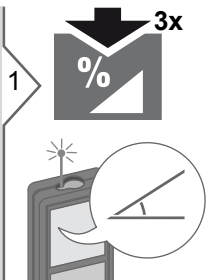

## Mittaustoiminnot

### Muistin (20 viimeisintä tulosta)

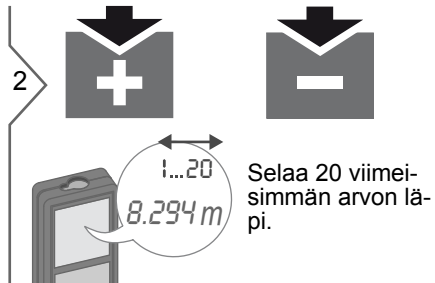
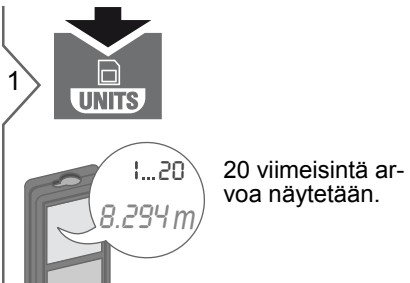

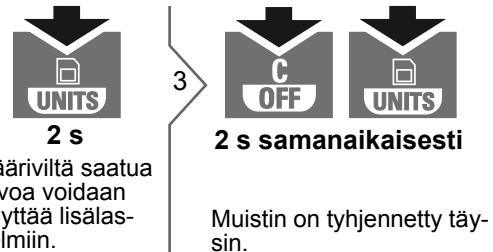

### Muistin tyhjennys





# Kalibrointi

## Kaltevuusanturin kalibrointi (Kallistuksen kalibrointi)

1  **2 s samanaikaisesti**

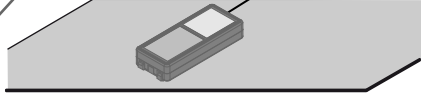
 MEAS 1  
HOR  
CAL

2  Aseta laite ehdottoman tasaiselle pinnalle.

3  **DIST**

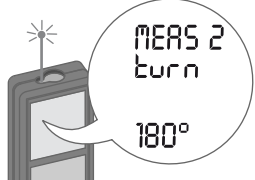
 MEAS 2  
turn  
180°

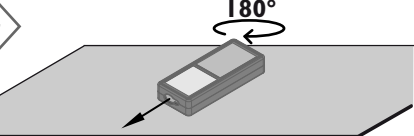
4  180°

Käännä laitetta vaakatasossa 180° ja aseta se uudestaan ehdottoman tasaiselle pinnalle.

5  **DIST**

 MEAS 3  
VER  
CAL

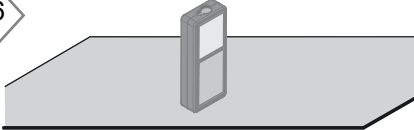
6  Käännä laite ylösalaisin ja aseta se uudestaan ehdottoman tasaiselle pinnalle.

7  **DIST**

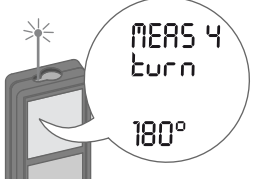
 MEAS 4  
turn  
180°

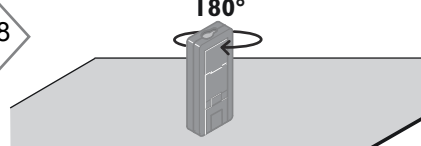
8  180°

Käännä laitetta vaakatasossa 180° ja aseta se uudestaan ehdottoman tasaiselle pinnalle.

9  **DIST**

 OK  
CAL

 2 sekunnin kuluttua laite menee takaisin normaaliin tilaan.

# Tekniset tiedot

Etäisyyden mittaus	
<b>Tyypillinen mittaustoleranssi</b> *	± 1,0 mm / 0,04 in ***
<b>Maksimimittaustoleranssi</b> **	± 2,0 mm / 0,08 in ***
<b>Kohdelevyn alue</b>	100 m / 330 ft
<b>Tyypillinen alue*</b>	80 m / 262 ft
<b>Alue epäsuotuisassa olosuhteissa ****</b>	60 m / 197 ft
<b>Pienin näytettävä yksikkö</b>	0,1 mm / 1/32 in
<b>Ø laserpiste etäisyyksillä</b>	6 /30 / 60 mm (10 / 50 / 100 m)
Kaltevuuden mittaus	
<b>Mittauksen toleransi lasersäteeseen*****</b>	± 0,2°
<b>Mittauksen toleransi koteloon*****</b>	± 0,2°
<b>Alue</b>	360°
Yleistä	
<b>Laserluokka</b>	2
<b>Lasertyyppi</b>	635 nm, < 1 mW
<b>Säteen divergenssi</b>	0,16 x 0,6 mrad
<b>Impulssin kesto</b>	0,2 x 10 <sup>-9</sup> s - 0,8 x 10 <sup>-9</sup> s
<b>Suojausluokka</b>	IP54 (pöly- ja roiskevesiuojattu)
<b>Autom. laserin päältä pois kytkeminen</b>	90 s jälkeen
<b>Autom. virran päältä pois kytkeminen</b>	180 s jälkeen
<b>Paristojen kestävyys (2 x AAA)</b>	enintään 5000 mittausta
<b>Mitat (K x S x L)</b>	125,2 x 58 x 32,6 mm 4,9 x 2,3 x 1,3 in
<b>Paino (paristojen kanssa)</b>	154 g / 5,43 oz
<b>Lämpötila-alue:</b>	
- Säilytys	-25 - 70 °C -13 - 158 °F
- Käyttö	-10 - 50 °C 14 - 122 °F

\* pätee 100 % kohteen heijastavuudelle (valkoinen maalattu seinä), heikko taustavalaistus, 25 °C

\*\* pätee 10 - 500 % kohteen heijastavuudelle, korkea taustavalaistus, - 10 °C - + 50 °C

\*\*\* Toleranssit pätevät välillä 0,05 m - 10 m luotettavuustasolla 95 %. Maksimitoleranssi voi huonontua arvoon 0,1 mm/m välillä 10 m - 30 m ja arvoon 0,2 mm/m yli 30 m:n etäisyyksillä

\*\*\*\* pätee 100 % kohteen heijastavuudelle, taustavalaistus noin 30'000 lux

\*\*\*\*\* käyttäjän kalibroinnin jälkeen. Lisäkulma +/- 0,01° astetta kohden poikkeaman yhteydessä +/-45° saakka kussakin kvadrantissa. Pätee huoneen lämpötilassa. Koko käyttölämpötila-alueelle maksimipoikkeama lisääntyä arvolla +/- 0,1°.

- i Tarkkoja epäsuoria tuloksia varten kolmijalan käyttö on suositeltavaa. Tarkkoja kallistusmittauksia varten poikittaista kallistusta tulee välttää.

Toiminnot	
<b>Etäisyyden mittaus</b>	kyllä
<b>Min./maks. -mittaus</b>	kyllä
<b>Jatkuva mittaus</b>	kyllä
<b>Vakiojako merkintä</b>	kyllä
<b>Yhteenlasku / Vähennyslasku</b>	kyllä
<b>Ala</b>	kyllä
<b>Tilavuus</b>	kyllä
<b>Pythagoras</b>	2-piste, 3-piste, osittainen korkeus
<b>Älykäs vaakatila / Epäsuora korkeus</b>	kyllä
<b>Korkeuden jäljittäminen</b>	kyllä
<b>Vaaitus</b>	kyllä
<b>Muisti</b>	20 arvoa
<b>Piippaus</b>	kyllä
<b>Valaistu näyttö</b>	kyllä
<b>Monikäyttöinen päätykappale</b>	kyllä

## Viestikoodit

Jos viesti **Virhe** ei katoa laitteen toistuvan päälle kytkemisen jälkeen, ota yhteyttä myyjään.

Jos viesti **Tiedot** ilmestyy numeron kanssa, paina Tyhjennä-painiketta ja noudata seuraavia ohjeita:

Nro	Syy	Korjaus
156	Poikittainen kallistus suurempi kuin 10°	Pidä kojetta ilman poikittaista kallistusta.
162	Kalibrointivirhe	Varmista, että laite on asetettu ehdottoman vaakasuoralle ja tasaiselle pinnalle. Toista kalibrointimenettely. Jos virhe vielä tapahtuu, ota yhteys jälleenmyyjään.
204	Laskentavirhe	Suorita mittaus uudelleen.
252	Lämpötila liian korkea	Jäähdytä laite.
253	Lämpötila liian matala	Lämmitä laite.
255	Vastaanotettu signaali liian heikko, mittausaika liian pitkä	Vaihda kohdepintaa (esim. valkoinen paperi).
256	Vastaanotettu signaali liian kirkas	Vaihda kohdepintaa (esim. valkoinen paperi).
257	Liikaa taustavaloa	Varjosta kohdealue.
258	Mittaus mittausalueen ulkopuolella.	Korjaa alue.
260	Lasersäteessä häiriö	Toista mittaus.

## Huolto

- Puhdista laite kostealla, pehmeällä kankaalla.
- Älä koskaan upota laitetta veteen.
- Älä koskaan käytä syövyttäviä puhdistusaineita tai liuottimia.

## Takuu

### Eurooppa:

- 30 päivän ei riskiä tyytyväisyystakuu
- Yhden vuoden ilmainen huolto
- Yhden vuoden täysi takuu

Yksityiskohtaiset tiedot on saatavissa internetissä osoitteessa [www.2helpU.com](http://www.2helpU.com).

### Pohjois-Amerikka:

- Kolmen vuoden rajoitettu takuu
- Yhden vuoden ilmainen huolto
- 90 päivän rahat takaisin -takuu

Yksityiskohtaiset tiedot on saatavissa internetissä osoitteessa [www.dewalt.com](http://www.dewalt.com).

## Turvallisuusohjeet

Henkilön, joka vastaa kojeesta, tulee varmistaa, että kaikki käyttäjät ymmärtävät nämä ohjeet ja noudattavat niitä.

### Vastuualueet

#### Aikuperäisen laitteiston valmistajan vastuut:

Eurooppa:  
DEWALT  
D-65510 Idstein, Germany  
[www.2helpU.com](http://www.2helpU.com)  
[www.dewalt.eu](http://www.dewalt.eu)

Pohjois-Amerikka:  
DEWALT Industrial Tool Co.  
Baltimore, MD21286, USA  
Soita huoltoon 1-800-4-DEWALT.  
[www.dewalt.com](http://www.dewalt.com)

Edellä mainittu yhtiö on vastuussa tuotteen toimittamisesta, Käyttöohje mukaanlukien, täysin turvallisessa kunnossa. Edellä mainittu yhtiö ei ole vastuussa kolmansien osapuolten tarvikkeista.

#### Laitteen vastuuhenkilön velvollisuudet:

- Ymmärtää laitteen turva- ja käyttöohjeet.
- Tuntea voimassa olevat paikalliset onnettomuuksien ennaltaehkäisyä koskevat säännöt.
- Estää aina valtuuttamattomien henkilöiden pääsyä käsiksi tuotteeseen.

## Turvallisuusohjeet

### Sallittu käyttö

- Etäisyyksien mittausta
- Kaltevuuden mittausta

### Kielletty käyttö

- Laitteen käyttö tuntematta käyttöohjeita
- Käyttö muissa kuin sallituissa toimintaolosuhteissa
- Turvajärjestelmien poistaminen sekä ohje- ja varoitustarrojen irrottaminen
- Kojeen avaaminen työkaluja käyttäen (ruuvimeisselit jne.)
- Muutosten teko laitteeseen
- Muiden valmistajien tarvikkeiden käyttäminen ilman suostumusta
- Muiden ihmisten tahallinen häikäisy, myös hämärässä
- Riittämätön mittaustilauksen suojaus (esim. suoritettaessa mittauksia kaduilla, rakennustyömailla jne.)
- Huolimaton ja vastuuton käyttö rakennustelineillä, tikkailla, käyviin koneiden lähellä, suojaamattomien koneiden ja niiden osien lähellä
- Tähtääminen suoraan aurinkoon

### Käyttöön liittyvät vaarat

#### VAROITUS

Tarkkaile mittaustulosten oikeellisuutta, jos laite on vioittunut, se on pudonnut, sitä on käytetty väärin tai sitä on muuteltu. Suorita aika ajoin koemittauksia. Varsinkin sen jälkeen kun laitetta on käytetty poikkeavasti, sekä ennen tärkeitä mittauksia että niiden jälkeen.

#### HUOMIO

Älä yritä korjata sitä itse. Ota vahinkojen sattuessa yhteyttä paikalliseen myyjään.

#### VAROITUS

Muutokset tai muunnelmät, joita ei nimenomaisesti ole hyväksytty, voivat mitätöidä käyttäjän valtuuden laitteiston käyttämiseen.

### Käytön rajoitukset

- Katso lisätietoja luvusta "Tekniset tiedot".

Laite on suunniteltu käytettäväksi alueilla, joilla on pysyvää ihmisasutusta. Älä käytä tuotetta räjähdysvaara-alueilla tai muutoin vaarallisissa ympäristöissä.

### Hävittäminen

#### HUOMAUTUS

Tyhjiä paristoja ei saa hävittää talousjätteen mukana. Huolehdi ympäristöstä ja vie ne kansallisten ja paikallisten säännösten mukaisesti järjestettyihin keräyspisteisiin. Tuotetta ei saa hävittää kotitalousjätteen mukana.

Hävitä laite asianmukaisesti maassasi voimassa olevien säädösten mukaisesti.



Noudata kansallisia ja maakohdittaisia säännöksiä.

Tuotekohtainen käsittely ja jätteidenhallinta voidaan ladata kotisivuiltamme.

### Sähkömagneettinen yhteensopivuus (EMC)

#### VAROITUS

Tämä laite on oleellisten standardien ja määräysten tiukimpien vaatimusten mukainen.

Häiriön aiheuttamisen mahdollisuutta muille laitteille ei kuitenkaan voida sulkea täysin pois.

## Laserluokitus

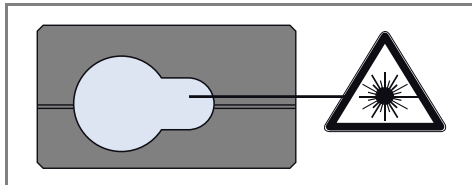

Laitte tuottaa näkyviä lasersäteitä, jotka säteilevät kojeesta:

Laitte on Luokan 2 lasertuote seuraavien määritysten perusteella:

- IEC60825-1 : 2007 "Lasertuotteiden säteilyturvallisuus"

### Laserluokan 2 tuotteet:

Älä katso suoraan lasersäteeseen äläkä suuntaa sitä tarpeettomasti kohti muita ihmisiä. Luontainen silmänräpäytysrefleksi suojaa silmiä normaalisti.

### **VAROITUS**

Suora katsominen säteeseen optisilla apuvälineillä (esim. kiikarit, kaukoputket) voi olla vaarallista.

### **HUOMIO**

Lasersäteeseen katsominen voi olla vaarallista silmille.

## Merkinnät

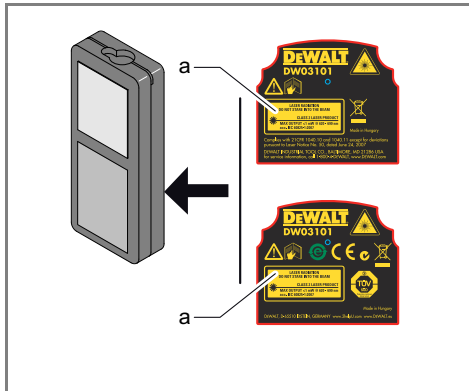

Liitä maasi kielinen lasertarra (a).

# Innhold

- Oppsett av instrumentet** .....-2
  - Innledning- .....-2
  - Oversikt .....-2
  - Skjerm .....-3
  - Sette i batterier .....-3
- Betjening** .....-4
  - Slå AV/PÅ .....-4
  - Slett .....-4
  - Meldingskoder .....-4
  - Endre målereferanse/stativ .....-4
  - Multifunksjons endestykke .....-5
  - Enhetsinnstilling for avstand .....-5
  - Enhetsinnstilling for helning .....-5
  - Tidstaker (automatisk utløsning) .....-5
  - Lydsignal AV/PÅ .....-6
  - Belysning AV/PÅ .....-6
- Målefunksjoner** .....-7
  - Måling av en enkelt avstand .....-7
  - Permanent / Min-maks måling .....-7
  - Addisjon/Subtraksjon .....-7
  - Areal .....-8
  - Volum .....-9
  - Trekant areal .....-10
  - Pytagoras (2-punkt) .....-11
  - Pytagoras (3-punkt) .....-11
  - Pytagoras (delvis høyde) .....-12
  - Utsetting .....-13
  - Smart Horisontalfunksjon .....-13
  - Høydesporing .....-14
  - Nivellering .....-14
  - Minne (20 siste vises) .....-15

- Slette minne .....-15
- Kalibrering** .....-16
  - Kalibrering av helningsføler (Helningskalibrering) --- -16
- Tekniske data** .....-17
- Meldingskoder** .....-18
- Vedlikehold** .....-18
- Garanti** .....-18
- Sikkerhetsinstrukser** .....-18
  - Ansvarsområder .....-18
  - Tillatt bruk .....-19
  - Ulovlig bruk .....-19
  - Farer ved bruk .....-19
  - Begrensning av bruk .....-19
  - Avfallshåndtering .....-19
  - Elektromagnetisk kompatibilitet (EMC) .....-19
  - Laserklassifisering .....-20
  - Merking .....-20

# NO Oppsett av instrumentet

## Innledning

 Sikkerhetsinstruksene og brukerhåndboken må leses nøye før utstyret tas i bruk for første gang.

 Den som er ansvarlig for instrumentet må sørge for at det brukes i samsvar med instruksjonene.

Symbolene som brukes har følgende betydninger:

### ADVARSEL

Angir en potensiell farlig situasjon eller utilsiktet bruk som kan medføre alvorlige personskader eller død, hvis ikke situasjonen blir unngått.

### OBS!

Angir potensiell farlig situasjon eller ikke tiltenkt bruk som, hvis den ikke unngås, kan føre til mindre personskader og/eller betydelige skader på utstyr og miljø, eller det kan få økonomiske følger.

 Viktige avsnitt må følges i praksis for å sikre at produktet brukes på en teknisk korrekt og effektiv måte.

## Oversikt

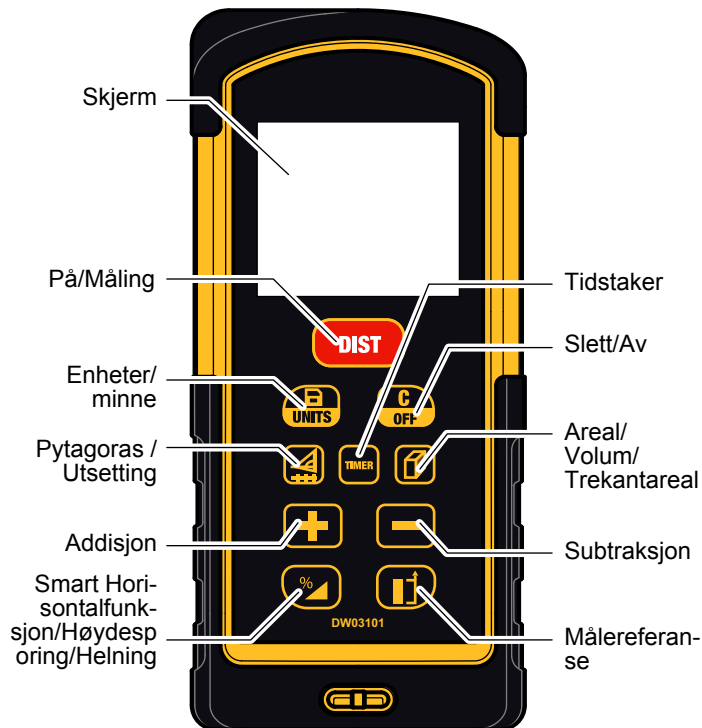

# Oppsett av instrumentet

## Skjerm

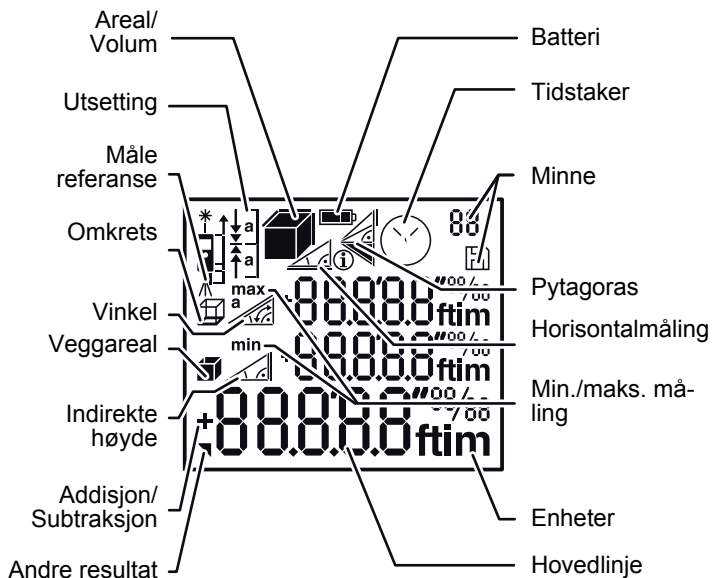

## Sette i batterier

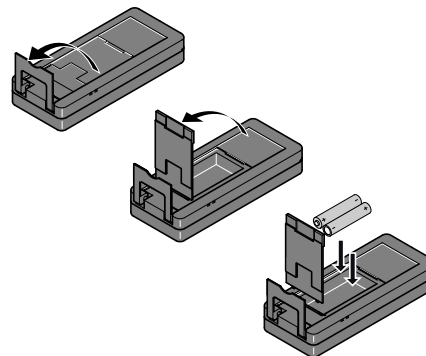

i

For å oppnå bedre pålitelighet bør man unngå bruk av sink-karbon-batterier. Bytt batteriene når batterisymbolet blinker.

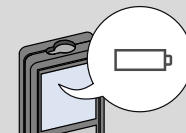

## Betjening

### Slå AV/PÅ



i

Trykk inn PÅ-tasten i to sekunder for å starte kontinuerlig laserfunksjon. Dersom ingen av tastene blir trykket på i løpet av 180 sekunder, vil enheten slå seg av automatisk.

### Slett

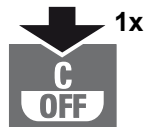

Angre siste handling.

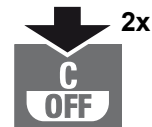

Gå ut av siste funksjon og gå til betjeningsfunksjon.

### Meldingskoder

Se instruksene i avsnittet "Meldingskoder" dersom informasjonsikonet vises med et nummer. Eksempel:



### Endre målereferanse/stativ

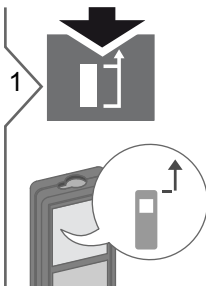

Avstanden måles fra enhetens framside.

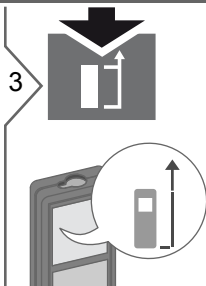
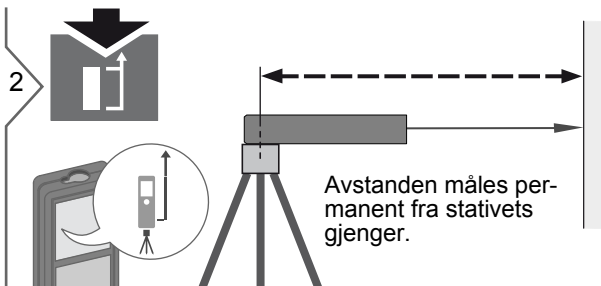

Avstanden måles fra enhetens bakside (standard innstilling).

# Betjening

## Multifunksjons endestykke

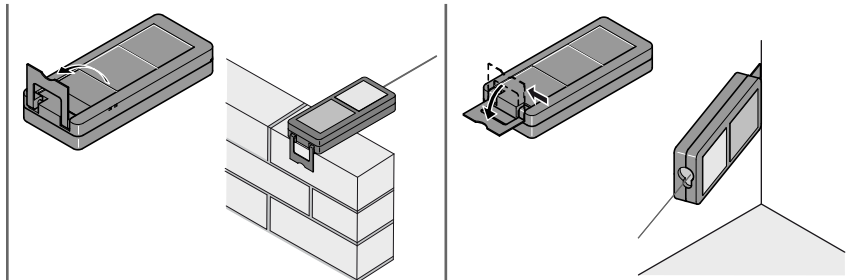

**i** Endestykkets orientering detekteres automatisk, og nullpunktet justeres tilsvarende.

## Enhetsinnstilling for avstand



2 sek.

Velg mellom følgende enheter:

0.000 m	0.00 ft
0.0000 m	0'00" 1/32
0.00 m	0.00 in
	0 in 1/32

## Enhetsinnstilling for helning



2 sek. samtidig



Velg mellom følgende enheter:

180 °
0.0 %

## Tidstaker (automatisk utløsning)

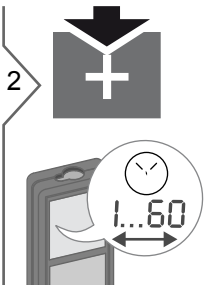
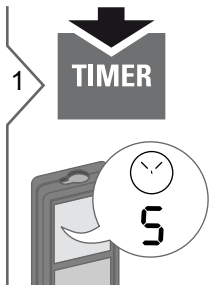

Juster forsinkelse for automatisk utløsning (maks. 60 sek, standardinnstilling 5 sek.)

**i** Når tasten slippes med aktiv laser, vil gjenstående sekunder til måling vises som nedtelling. Forsinket utløsning anbefales for nøyaktig sikting ved for eksempel lange avstander. Det forhindrer vibrasjoner i enheten som oppstår når det trykkes på måletasten.

# Betjening

## Lydsignal AV/PÅ



2 sek. samtidig

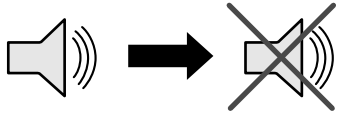

## Belysning AV/PÅ



2 sek. samtidig

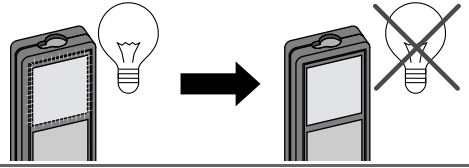

# Målefunksjoner

## Måling av en enkelt avstand

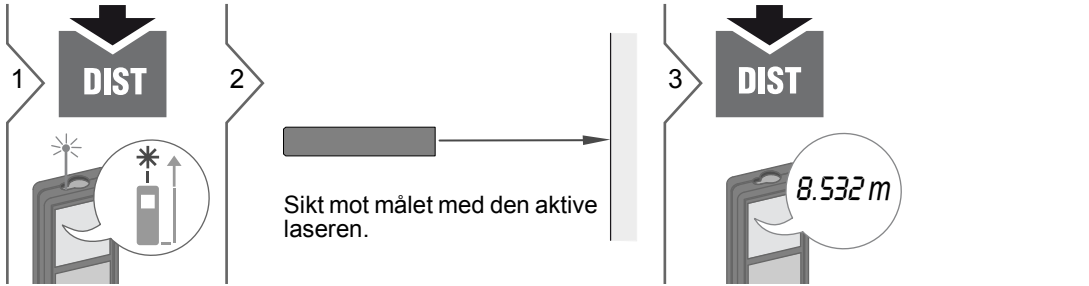

**i** Måleflater: Målefeil kan oppstå ved måling mot fargeløse væsker, glass, styropor, delvis transparente overflater eller høyblanke flater. Mot mørke flater vil måletiden øke.

## Permanent / Min-maks måling

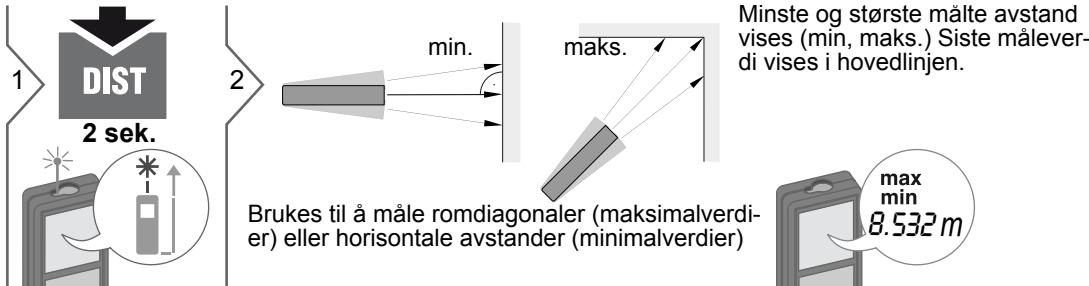

Stopper permanent / min-maks måling.

## Addisjon/Subtraksjon

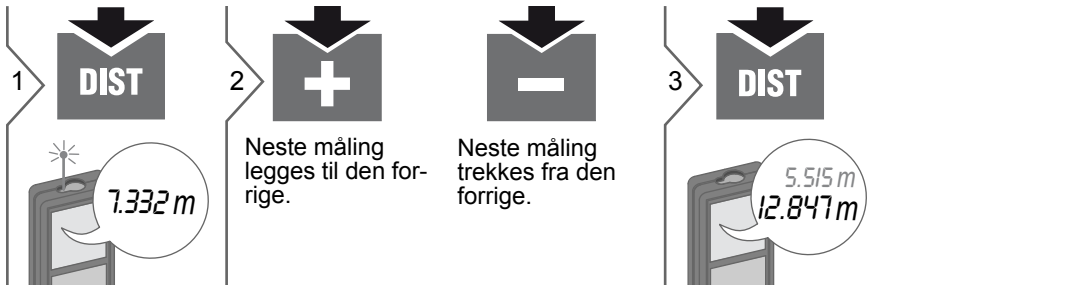

**i** Resultatet vises i hovedlinjen, og den målte verdien vises ovenfor. Denne prosessen gjentas ved behov. Samme fremgangsmåte kan brukes for å legge til eller trekke fra arealer eller volum.

Areal

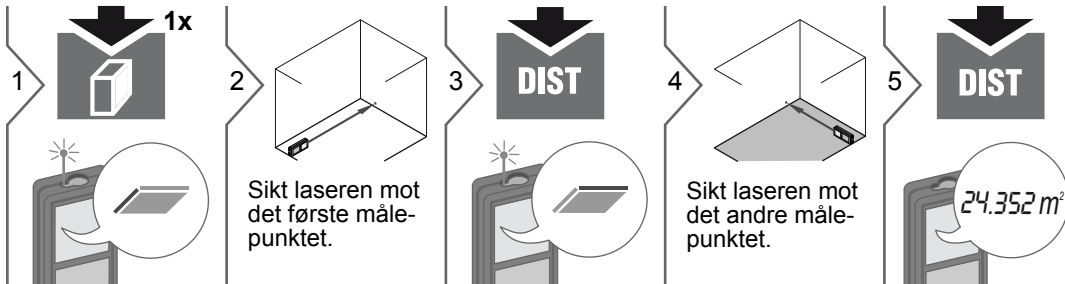

i

Resultatet vises i hovedlinjen, og den målte verdien vises ovenfor.

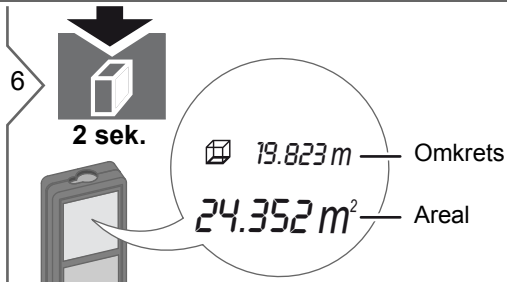

# Målefunksjoner

## Volum

1 **2x**

2 Sikt laseren mot det første målepunktet.

3 **DIST**

4 Sikt laseren mot det andre målepunktet.

5 **DIST**

6 Sikt laseren mot det tredje målepunktet.

7 **DIST** **i** Resultatet vises i hovedlinjen, og den målte verdien vises ovenfor. **78.694 m<sup>3</sup>**

8 **2 sek.** **80.208 m** — Omkrets  
**208.703 m<sup>2</sup>** — Veggarealer  
**78.694 m<sup>3</sup>** — Volum

Trekant areal

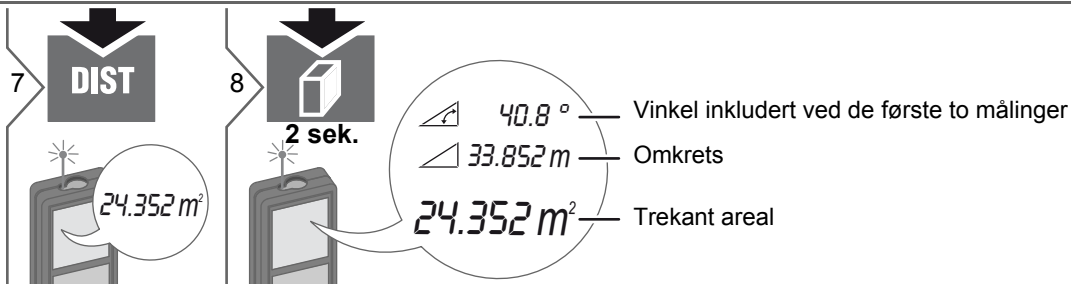
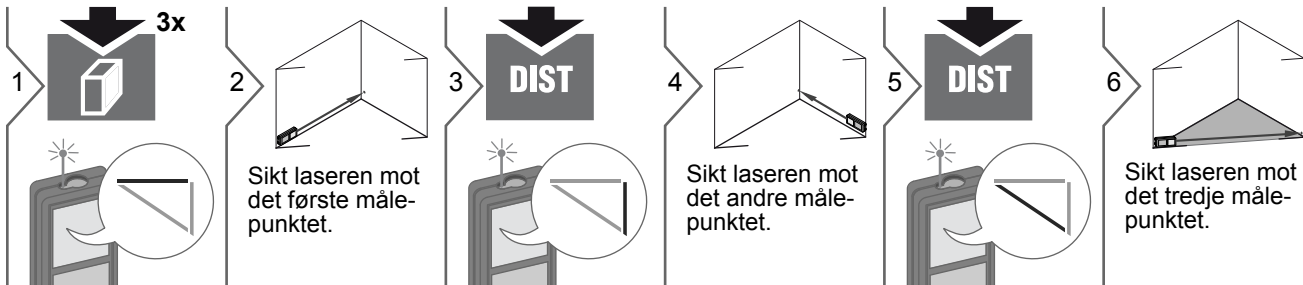

# Målefunksjoner

## Pytagoras (2-punkt)

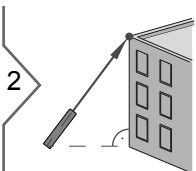
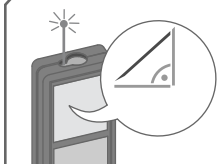

Sikt laseren mot det øverste punktet.

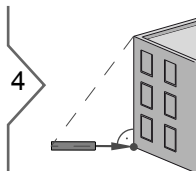
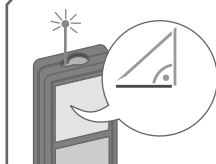

Sikt laseren rektangulært mot det nederste punktet.

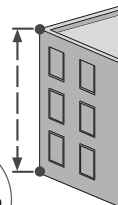

i

Resultatet vises i hovedlinjen, og den målte verdien vises ovenfor. Ved å trykke på måletasten 2 sekunder i funksjonen aktiveres minimums- eller maksimums-måling automatisk.

## Pytagoras (3-punkt)

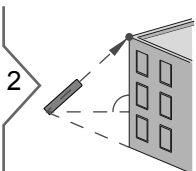
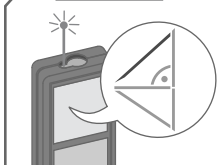

Sikt laseren mot det øverste punktet.

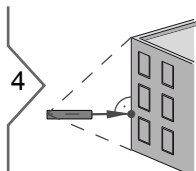

Sikt laseren mot det rektangulære punktet.

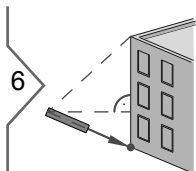

Sikt laseren mot det la-veste punktet.

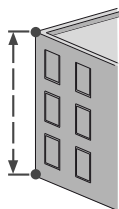

i

Resultatet vises i hovedlinjen, og den målte verdien vises ovenfor. Ved å trykke på måletasten 2 sekunder i funksjonen aktiveres minimums- eller maksimums-måling automatisk.

# Målefunksjoner

## Pytagoras (delvis høyde)

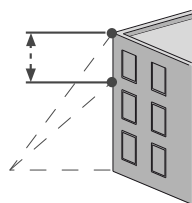
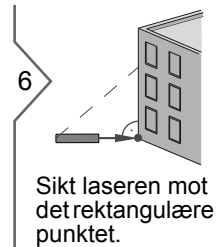
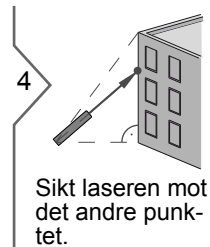
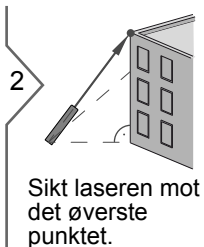
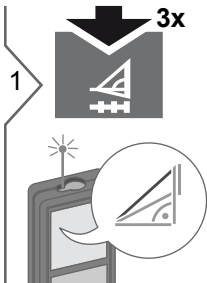

**i** Resultatet vises i hovedlinjen, og den målte verdien vises ovenfor. Ved å trykke på måletasten 2 sekunder i funksjonen aktiveres minimums- eller maksimumsmåling automatisk.

# Målefunksjoner

## Utsetting

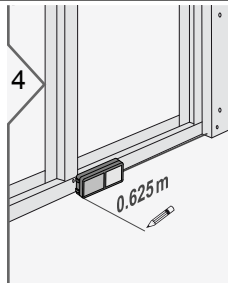
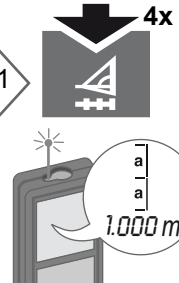
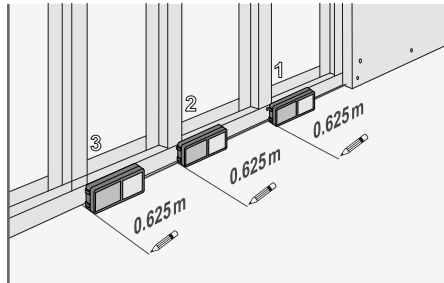

Flytt enheten sakte langs utsetningslinjen. Avstanden til det neste utsetningspunktet vises.

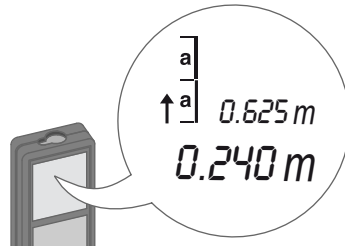

0,240 m gjenstår til neste 0,625 m avstand.

**i** Instrumentet vil begynne å pipe når avstanden til neste utsetningspunkt er mindre enn 0,1 m. Funksjonen stoppes ved å trykke på tasten SLETT/AV.

## Smart Horisontalfunksjon

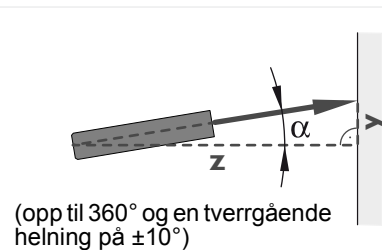
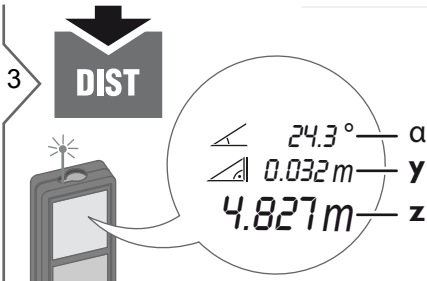
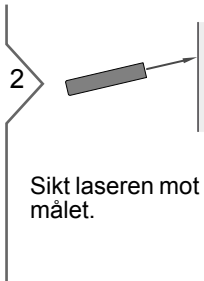
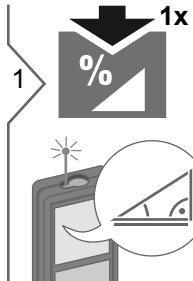

(opp til 360° og en tverrgående helning på  $\pm 10^\circ$ )

**i** Trykk på tasten igjen for å slå av horisontal måling.

# NO Målefunksjoner

## Høydesporing

Denne funksjonen viser kontinuerlig sporingshøyden dersom enheten dreies på et stativ. Det er ikke nødvendig med en andre måling siden det kun er vinkelen som måles automatisk.

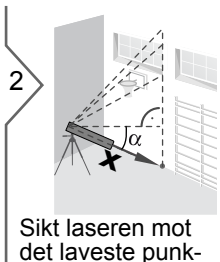
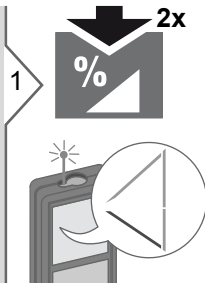

Sikt laseren mot det laveste punk-

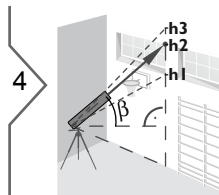

Sikt laseren mot de øvre punktene og vinkel/høydesporing starter automatisk.

5

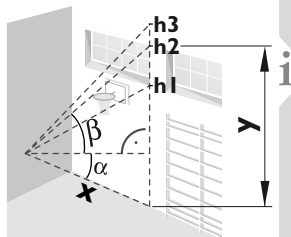
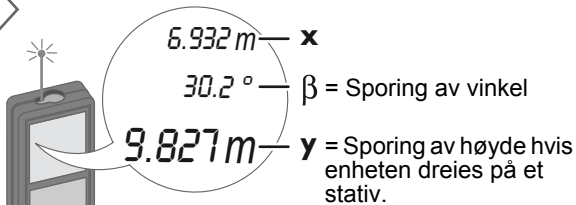

Sporet høyde "y" er 90° i forhold til de først tilskittede punktet "x".

6



Stopper høydesporing og viser siste måling.

## Nivellering

Denne funksjonen viser kontinuerlig enhetens helning. Fra en helning på  $\pm 5^\circ$  starter enheten å avgi pipetoner regelmessig. Jo nærmere den kommer  $0^\circ$  jo hyppigere kommer pipetone. Dersom helningen blir  $\pm 0,3^\circ$  vil enheten avgi kontinuerlig pipetone.

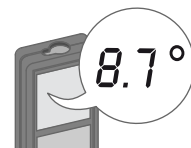
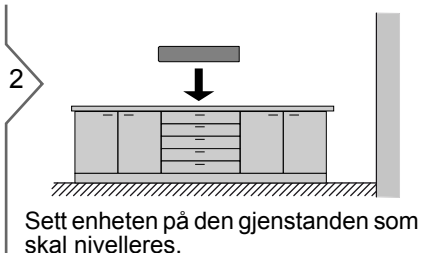
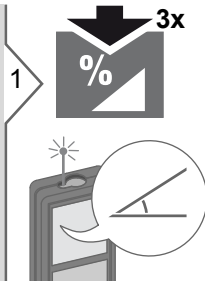

Helningen vises (område  $\pm 180^\circ$ ).

# Målefunksjoner

## Minne (20 siste vises)



1



De 20 siste visningene vises.



2



Blar gjennom de 20 siste visningene.





## Slette minne

3



**2 sek.**



**2 sekunder samtidig**

Minnet er fullstendig slettet.

Verdien fra hovedlinjen kan brukes til framtidige beregninger.

# Kalibrering

## Kalibrering av helningsføler (Helningskalibrering)

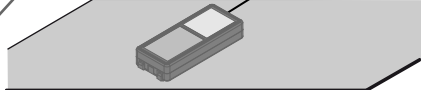

1  2 sek. samtidig

 MEAS 1  
HOR  
CAL

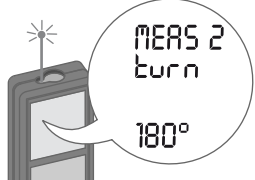
2  Plasser enheten på en helt plan flate.

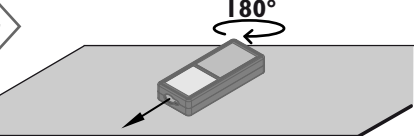
3   MEAS 2  
turn  
180°

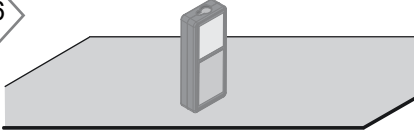

4  180°  
Drei enheten horisontalt 180° og legg den tilbake på en helt plan flate.

5   MEAS 3  
VER  
CAL

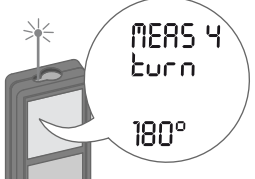
6  Snu enheten opp ned 180° og legg den tilbake på en helt plan flate.

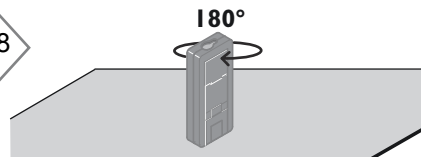
7   MEAS 4  
turn  
180°

8  180°  
Drei enheten horisontalt 180° og legg den tilbake på en helt plan flate.

9   OK  
CAL

 Etter to sekunder går enheten tilbake til normalfunksjonen.

# Tekniske data

Avstandsmåling	
Typisk måletoleranse*	± 1.0 mm / 0.04 in ***
Maksimal måletoleranse**	± 2.0 mm / 0.08 in ***
Område for målplate	100 m / 330 ft
Typisk rekkevidde*	80 m / 262 ft
Avstand ved ugunstige forhold ****	60 m / 197 ft
Minste viste enhet	0,1 mm / 1/32 in
Ø laserpunkt ved avstandene	6 /30 / 60 mm (10 / 50 / 100 m)
Helningsmåling	
Måletoleranse mot laserstråle *****	± 0.2°
Måletoleranse mot kapsling *****	± 0.2°
Rekkevidde	360°
Generelt	
Laserklasse	2
Lasertype	635 nm, < 1 mW
Stråledivergens	0,16 x 0,6 mrad
Impulsvarighet	0,2 x 10 <sup>-9</sup> s - 0,8 x 10 <sup>-9</sup> s
Kapslingsgrad	IP54 (beskyttet mot støv og vannsprut)
Automatisk utkobling av laser	etter 90 s.
Automatisk utkobling av instrument	etter 180 s.
Batterienes levetid (2 X AAA)	Opp til 5000 målinger
Dimensjoner (H X D X B)	125,2 x 58 x 32,6 mm 4,9 x 2,3 x 1,3 in
Vekt (med batterier)	154 g / 5.43 oz
Temperaturområde:	
- Lagring	-25 til 70 °C -13 til 158 °F
- Bruk	-10 til 50 °C 14 til 122 °F

\* gjelder for 100 % refleksjon fra målet (hvitmalt vegg), lav bakgrunnsbelysning, 25 °C

\*\* gjelder for 10 til 500 % refleksjon fra mål, høy bakgrunnsbelysning, - 10 °C til + 50 °C

\*\*\* Toleranse gjelder fra 0.05 m til 10 m med sikkerhetsnivå på 95%. Den maksimale toleransen kan forringes med 0.1 mm/m mellom 10 m og opp til 30 m og 0,2 mm/m for avstander over 30 m.

\*\*\*\* gjelder for 100 % refleksjon fra målet, bakgrunnsbelysning på ca. 30.000 lux

\*\*\*\*\* etter brukerkalibrering. Ytterligere vinkelrelaterte avvik på +/- 0,01° per grad opp til +/-45° i hver kvadrant. Gjelder ved romtemperatur. For hele spektret av driftstemperatur øker det maksimale avviket med +/- 0,1°.

i Bruk av stativ anbefales for nøyaktige indirekte resultater. For nøyaktige helningsmålinger bør tverrhelning unngås.

Funksjoner	
Avstandsmåling	Ja
Min/Maks måling	Ja
Permanent måling	Ja
Utsetting	Ja
Addisjon/subtraksjon	Ja
Areal	Ja
Volum	Ja
Pytagoras	2-punkt, 3-punkt, delvis høyde
Smart Horisontalfunksjon / Indirekte høyde	Ja
Høydesporing	Ja
Nivellering	Ja
Minne	20 visninger
Pip	Ja
Belyst skjerm	Ja
Multifunksjons endestykke	Ja

## Meldingskoder

Kontakt forhandleren dersom meldingen **Error** ikke forsvinner etter at enheten er slått på gjentatte ganger.

Trykk på slettetasten dersom meldingen **InFo** vises med et nummer, og følg disse instruksene:

Nr.	Årsak	Tiltak
156	Tverrhelning større en 10°	Hold instrumentet uten tverrhelning.
162	Kalibreringsfeil	Sørg for at enheten plasseres på en fullstendig horisontal og plan flate. Gjenta kalibreringen. Kontakt forhandleren dersom feilen vedvarer.
204	Beregningsfeil	Mål på nytt.
252	Temperatur for høy	Kjøl ned enheten.
253	Temperatur for lav	Varm opp enheten.
255	Mottatt signal for svakt, for lang måletid	Bytt måleflate (f.eks. hvitt papir).
256	Mottatt signal for kraftig	Bytt måleflate (f.eks. hvitt papir).
257	For mye bakgrunnslys	Skyggelegg målområdet.
258	Måling utenfor måleområde	Riktig område.
260	Brutt laserstråle	Gjenta målingen.

## Vedlikehold

- Rengjør enheten med en fuktig myk klut.
- Enheten må aldri senkes i vann.
- Bruk aldri sterke rengjøringsmidler eller løsemidler.

## Garanti

### Europa:

- 30 dagers fornøydgaranti – risikofritt!
- Ett års gratis service
- Ett års full garanti

Mer detaljert informasjon finner du på internett, på [www.2helpU.com](http://www.2helpU.com).

### Nord-Amerika:

- Tre års begrenset garanti
- Ett års gratis service
- 90 dagers pengene tilbake-garanti

Mer detaljert informasjon finner du på internett, på [www.dewalt.com](http://www.dewalt.com).

## Sikkerhetsinstrukser

Den som er ansvarlig for instrumentet må sørge for at det brukes i samsvar med instruksjonene.

### Ansvarsområder

#### Ansvar til produsenten av originalutstyret:

Europa:  
DEWALT  
D-65510 Idstein, Germany  
[www.2helpU.com](http://www.2helpU.com)  
[www.dewalt.eu](http://www.dewalt.eu)

Nord-Amerika:  
DEWALT Industrial Tool Co.  
Baltimore, MD21286, USA  
For service ringer du 1-800-4-DEWALT.  
[www.dewalt.com](http://www.dewalt.com)

Firmaet ovenfor er ansvarlig for å levere produktet, inklusive brukerhåndboken, i sikker stand. Firmaet ovenfor er ikke ansvarlig for utstyr fra tredjepart.

#### Ansvarsområdet til den som har ansvar for instrumentet:

- Vedkommende skal forstå sikkerhetsinformasjonen på produktet og instruksjonene i brukerhåndboken.
- Vedkommende skal kjenne de stedlige forskrifter for arbeidsmiljø og sikkerhet.
- Vedkommende skal hindre uvedkommende i å få adgang til produktet.

## Sikkerhetsinstruksjoner

### Tillatt bruk

- Måling av avstander
- Helningsmåling

### Ulovlig bruk

- Bruke instrumentet uten instruksjoner
- Bruk utenfor angitte grenseverdier
- Deaktivering av sikkerhetssystemer og fjerning av forklarende merking og faremerker
- Åpning av produktet ved bruk av verktøy (skrutrekkere etc.)
- Utføre modifikasjoner eller endring av produktet
- Bruk av tilbehør fra andre produsenter uten uttrykkelig godkjenning
- Bevisst blanding av andre, også i mørket
- Utilstrekkelige sikkerhetstiltak på arbeidsstedet (som for eksempel ved måling på veier, anleggsplasser etc.)
- Utilbørlig eller uansvarlig oppførsel på stillaser, i stiger, ved måling i nærheten av maskiner som går, eller i nærheten av maskiner eller installasjoner som ikke er beskyttet
- Sikting direkte mot solen

### Farer ved bruk

#### ADVARSEL

Se opp for feilmålinger hvis det er feil ved instrumentet, hvis det har falt i bakken, hvis det har vært brukt på feil måte eller hvis det er blitt ombygd. Utfør regelmessige testmålinger.

Særlig etter at instrumentet har vært utsatt for ekstreme belastninger samt før og etter viktige målinger.

#### OBS!

Forsøk aldri å reparere produktet selv. Kontakt en lokal forhandler hvis produktet er skadet.

#### ADVARSEL

Endringer eller modifikasjoner som ikke er uttrykkelig godkjent, kan hindre brukerens rett til å betjene utstyret.

### Begrensning av bruk

- Se avsnittet "Tekniske data".
- Enheten egner seg til bruk på steder der mennesker kan oppholde seg permanent. Produktet må ikke benyttes i eksplosjonsfarlig eller aggressivt miljø.

### Avfallshåndtering

#### OBS!

Brukte batterier må ikke kastes i husholdningsavfallet. Vern om miljøet og send dem til oppsamlingsstasjoner som er beregnet til dette i henhold til nasjonale eller lokale forskrifter.

Produktet må ikke kastes i husholdningsavfallet.

Utstyret må kasseres på forsvarlig måte i samsvar med gjeldende nasjonale forskrifter.



Følg nasjonale og landsspesifikke bestemmelser.

Informasjon om produktspesifikk behandling og håndtering av avfall kan lastes ned fra hjemmesiden vår.

### Elektromagnetisk kompatibilitet (EMC)

#### ADVARSEL

Enheten oppfyller de strenge kravene ifølge gjeldende retningslinjer og normer. Likevel kan muligheten for forstyrrelse av andre apparater ikke helt utelukkes.

## Laserklassifisering

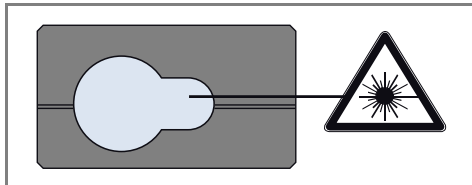

Enheten produserer en synlig laserstråle som kommer ut fra instrumentet:

Produktet er i samsvar med laserklasse 2 ifølge:

- IEC60825-1 : 2007 "Strålingssikkerhet for laserutstyr"

### Laserklasse 2 produkter:

Unngå å se inn i laserstrålen og å rette den unødig mot andre personer. Øynene vil vanligvis beskyttes ved at man snur seg bort og ved å lukke øynene.

### **⚠ ADVARSEL**

Det kan være farlig å se direkte inn i laserstrålen med optiske hjelpemidler (som f.eks. lupe eller kikkert).

### **⚠ OBS!**

Det kan være farlig for øynene å se inn i laserstrålen.

## Merking

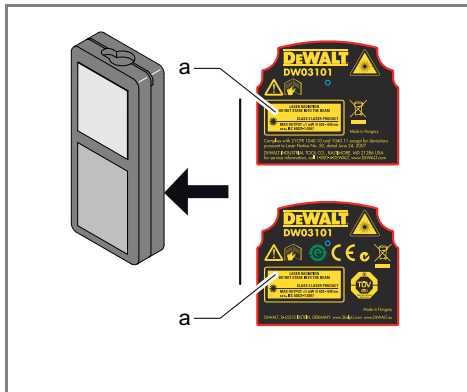

Fest lasermerket (a) med landets språk.

## Πίνακας περιεχομένων

<b>Ρύθμιση οργάνου</b> .....	<b>2</b>
Εισαγωγή .....	2
Συνοπτική παρουσίαση .....	2
Ένδειξη .....	3
Τοποθέτηση μπαταριών .....	3
<b>Χειρισμός</b> .....	<b>4</b>
Ενεργοποίηση/απενεργοποίηση .....	4
Εκκαθάριση .....	4
Κωδικοί μηνυμάτων .....	4
Ρύθμιση επιπέδου μέτρησης / τρίποδο .....	4
Τελικό εξάρτημα πολλαπλών λειτουργιών .....	5
Ρύθμιση μονάδας απόστασης .....	5
Ρύθμιση μονάδας κλίσης .....	5
Χρονοδιακόπτης (αυτόματη ενεργοποίηση) .....	5
Ενεργοποίηση/απενεργοποίηση Beep .....	6
Ενεργοποίηση/απενεργοποίηση φωτισμού .....	6
<b>Λειτουργίες μέτρησης</b> .....	<b>7</b>
Μέτρηση μεμονωμένης απόστασης .....	7
Μέτρηση μόνιμης /ελάχιστης-μέγιστης απόστασης .....	7
Πρόσθεση / Αφαίρεση .....	7
Εμβαδόν .....	8
Όγκος .....	9
Εμβαδόν τριγώνου .....	10
Πυθαγόρας (2 σημεία) .....	11
Πυθαγόρας (3 σημεία) .....	11
Πυθαγόρας (μερικό ύψος) .....	12
Χάραξη .....	13
Έξυπνη οριζόντια λειτουργία .....	13
Ανίχνευση ύψους .....	14
Οριζοντίωση .....	14
Μνήμη (20 τελευταίες ενδείξεις) .....	15

Διαγραφή μνήμης .....

15

## **Βαθμονόμηση** .....

16

Βαθμονόμηση αισθητήρα κλίσης

(Βαθμονόμηση κλίσης) .....

16

## **Τεχνικά χαρακτηριστικά** .....

17

## **Κωδικοί μηνυμάτων** .....

18

## **Φροντίδα** .....

18

## **Εγγύηση** .....

18

## **Οδηγίες ασφαλείας** .....

18

Τομείς ευθύνης .....

18

Επιτρεπόμενη χρήση .....

19

Μη επιτρεπόμενη χρήση .....

19

Κίνδυνοι κατά τη χρήση .....

19

Περιορισμοί χρήσης .....

19

Απόρριψη .....

19

Ηλεκτρομαγνητική συμβατότητα (ΗΜΣ) .....

19

Κατηγορία λείζερ .....

20

Πινακίδες .....

20

## Εισαγωγή

 Διαβάστε προσεκτικά τις οδηγίες ασφαλείας και το εγχειρίδιο χρήσης πριν χρησιμοποιήσετε το προϊόν για πρώτη φορά.

 Ο υπεύθυνος του προϊόντος πρέπει να διασφαλίσει ότι όλοι οι χρήστες κατανοούν και τηρούν αυτές τις οδηγίες.

Τα σύμβολα που χρησιμοποιούνται έχουν την ακόλουθη σημασία:

## ΠΡΟΕΙΔΟΠΟΙΗΣΗ

Υποδηλώνει μια δυνητικά επικίνδυνη κατάσταση ή ακούσια χρήση η οποία, αν δεν αποφευχθεί, ενδέχεται να προκαλέσει θάνατο ή σοβαρό τραυματισμό.

## ΠΡΟΣΟΧΗ

Υποδηλώνει μια δυνητικά επικίνδυνη κατάσταση ή ακούσια χρήση η οποία, αν δεν αποφευχθεί, ενδέχεται να προκαλέσει μικρό τραυματισμό ή σημαντική υλική, οικονομική ή περιβαλλοντική ζημιά.

**i** Σημαντικές παράγραφοι που πρέπει να λαμβάνονται υπόψη κατά τη χρήση του οργάνου, καθώς επιτρέπουν την τεχνικά ορθή και αποδοτική χρήση του.

## Συνοπτική παρουσίαση



# Ρύθμιση οργάνου

## Ένδειξη

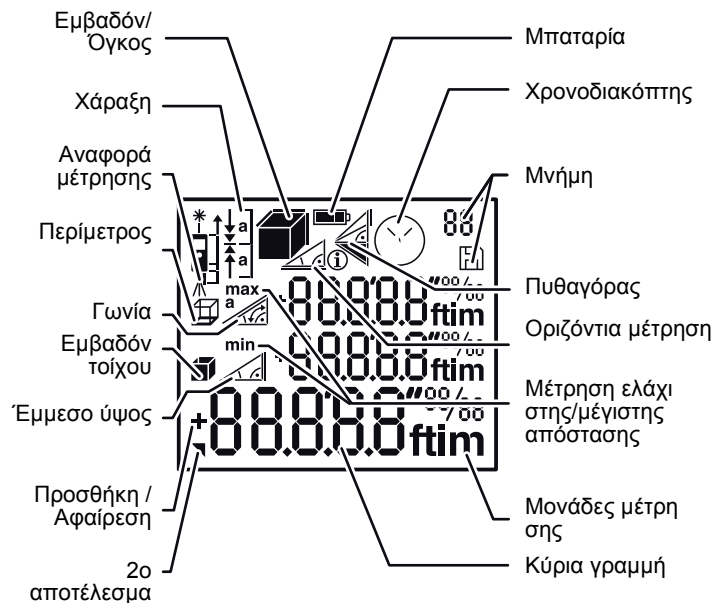

## Τοποθέτηση μπαταριών

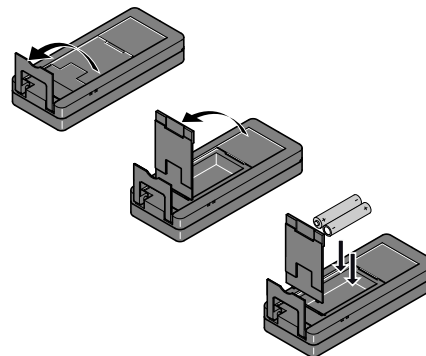

i

Για να διασφαλιστεί η αξιόπιστη χρήση, μη χρησιμοποιείτε μπαταρίες ψευδαργύρου-άνθρακα. Αλλάζετε τις μπαταρίες όταν το σύμβολο αναβοσβήνει.

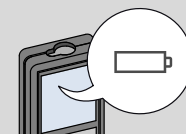

### Ενεργοποίηση/απενεργοποίηση



**i** Πατήστε το κουμπί ON επί 2 δευτ. για να αρχίσει η συνεχής λειτουργία του λέιζερ. Εάν δεν πατήσετε κάποιο πλήκτρο επί 180 δευτ., η συσκευή απενεργοποιείται αυτόματα.

### Εκκαθάριση

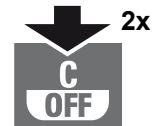
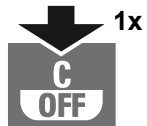

### Κωδικόι μηνυμάτων

Εάν εμφανιστεί το εικονίδιο πληροφοριών μαζί με έναν αριθμό, ανατρέξτε στις οδηγίες στην ενότητα "Κωδικοί μηνυμάτων".  
Παράδειγμα:



### Ρύθμιση επιπέδου μέτρησης / τρίποδο

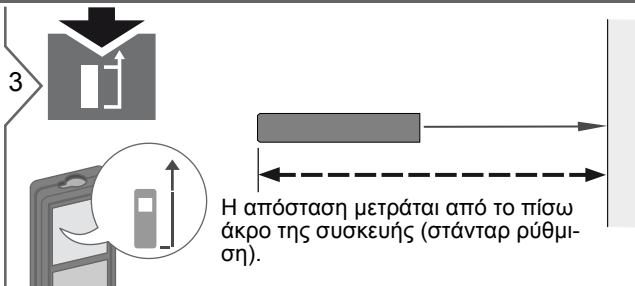
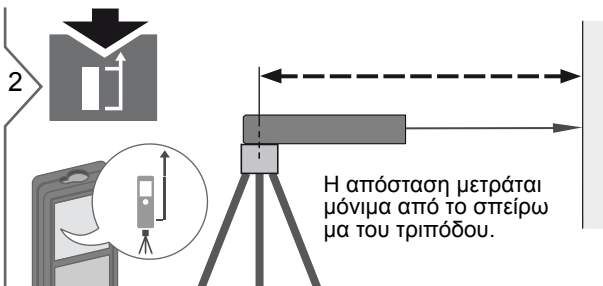
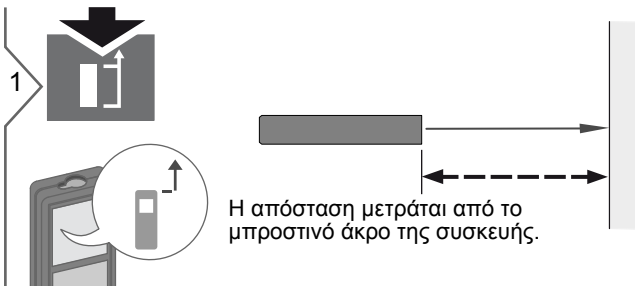

# Χειρισμός

## Τελικό εξάρτημα πολλαπλών λειτουργιών

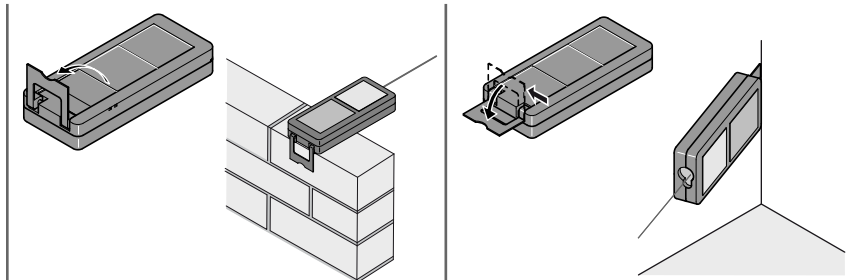

**i** Η προσανατολισμός του τελικού εξαρτήματος ανιχνεύεται αυτόματα και το μηδενικό σημείο ρυθμίζεται ανάλογα.

## Ρύθμιση μονάδας απόστασης Ρύθμιση μονάδας κλίσης



2 δευτ.

Εναλλαγή μεταξύ των παρακάτω μονάδων:

0.000 m	0.00 ft
0.0000 m	0'00" 1/32
0.00 m	0.00 in
	0 in 1/32



2 δευτ. ταυτόχρονα

Εναλλαγή μεταξύ των παρακάτω μονάδων:

180 °
0.0 %

## Χρονοδιακόπτης (αυτόματη ενεργοποίηση)

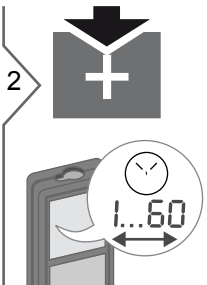
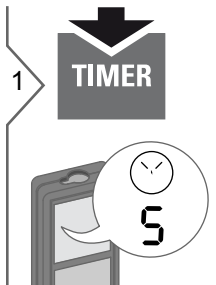

**+**  
Ρυθμίστε την καθυστέρηση της αυτόματης ενεργοποίησης (μέγ. 60 δευτ., στάνταρ ρύθμιση 5 δευτ.)

**i** Μόλις αφήσετε το πλήκτρο με το λέιζερ ενεργοποιημένο, εμφανίζονται σε αντίστροφη μέτρηση τα δευτερόλεπτα που απομένουν μέχρι τη μέτρηση. Η καθυστέρηση έκδοσης συνιστάται για την ακριβή στόχευση π.χ. σε μεγάλες αποστάσεις. Αποτρέπει τους κραδασμούς της συσκευής όταν πατάτε το πλήκτρο μέτρησης.

## Χειρισμός

### Ενεργοποίηση/απενεργοποίηση Βεep



2 δευτ.  
ταυτόχρονα

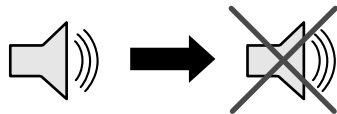

### Ενεργοποίηση/απενεργοποίηση φωτισμού



2 δευτ.  
ταυτόχρονα

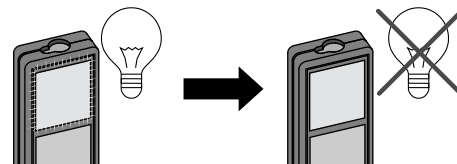

# Λειτουργίες μέτρησης

## Μέτρηση μεμονωμένης απόστασης

1 **DIST**



2

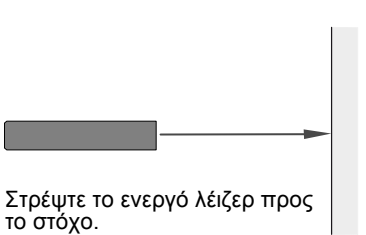

3 **DIST**



8.532 m

Στρέψτε το ενεργό λέιζερ προς το στόχο.

**i** Επιφάνειες στόχοι: Μπορεί να παρατηρηθούν σφάλματα μέτρησης όταν πραγματοποιείτε μέτρηση σε άχρωμα υγρά, γυαλί, φελιζόλ ή ημιδιαπερατές επιφάνειες ή όταν το λέιζερ είναι στραμμένο με πολύ γυαλιστερές επιφάνειες. Σε σκούρες επιφάνειες, ο χρόνος μέτρησης αυξάνεται.

## Μέτρηση μόνιμης /ελάχιστης-μέγιστης απόστασης

1 **DIST**  
2 δευτ.



2

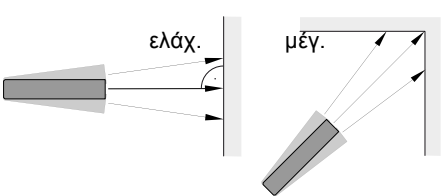

ελάχ. μέγ.

3 **DIST**

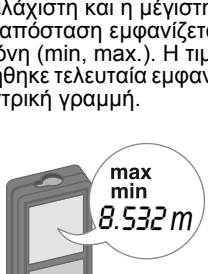

max  
min  
8.532 m

Χρησιμοποιείται για τη μέτρηση διαγώνιας (μέγιστες τιμές) ή οριζόντιας απόστασης (ελάχιστες τιμές)

Η ελάχιστη και η μέγιστη μετρούμενη απόσταση εμφανίζεται στην οθόνη (min, max.). Η τιμή που μετρήθηκε τελευταία εμφανίζεται στην κεντρική γραμμή.

**i** Διακόπτει τη μέτρηση μόνιμης /ελάχιστης-μέγιστης απόστασης.

## Πρόσθεση / Αφαίρεση

1 **DIST**



7.332 m

2 **+**



3 **-**



4 **DIST**



5.515 m  
12.847 m

Η επόμενη μέτρηση προστίθεται στην προηγούμενη.

Η επόμενη μέτρηση αφαιρείται από την προηγούμενη.

**i** Το αποτέλεσμα εμφανίζεται στην κεντρική γραμμή και η μετρηθείσα τιμή εμφανίζεται από πάνω. Μπορείτε να επαναλάβετε αυτή τη διαδικασία όπως επιθυμείτε. Μπορείτε να χρησιμοποιήσετε την ίδια διαδικασία για να προσθέσετε ή να αφαιρέσετε εμβαδά ή γκούς.

Εμβαδόν

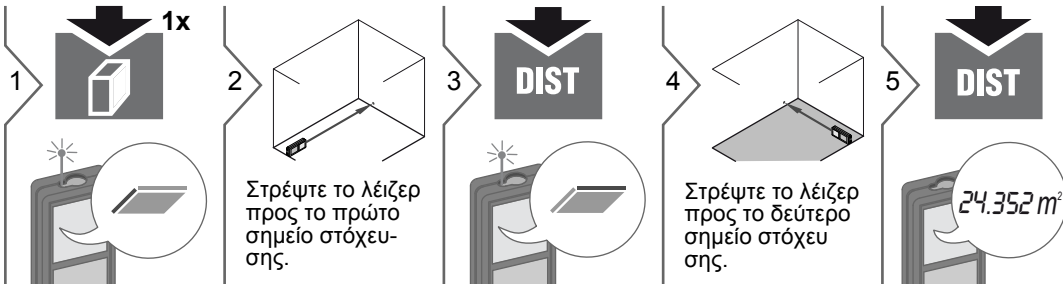

i

Το αποτέλεσμα εμφανίζεται στην κεντρική γραμμή και η μετρηθείσα τιμή εμφανίζεται από πάνω.

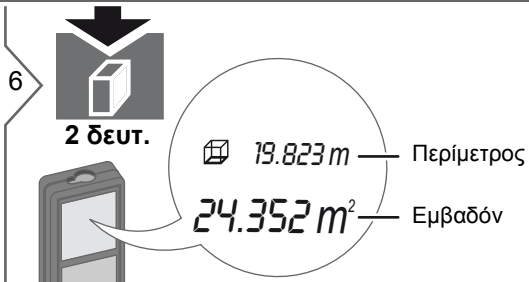

# Λειτουργίες μέτρησης

## Όγκος

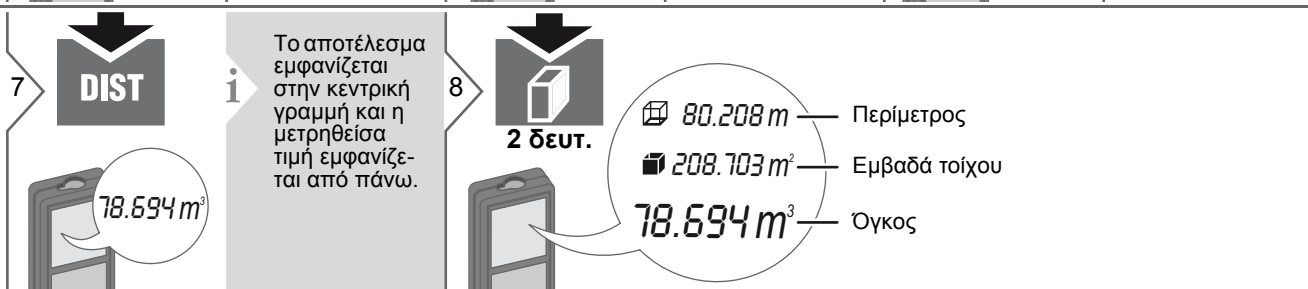
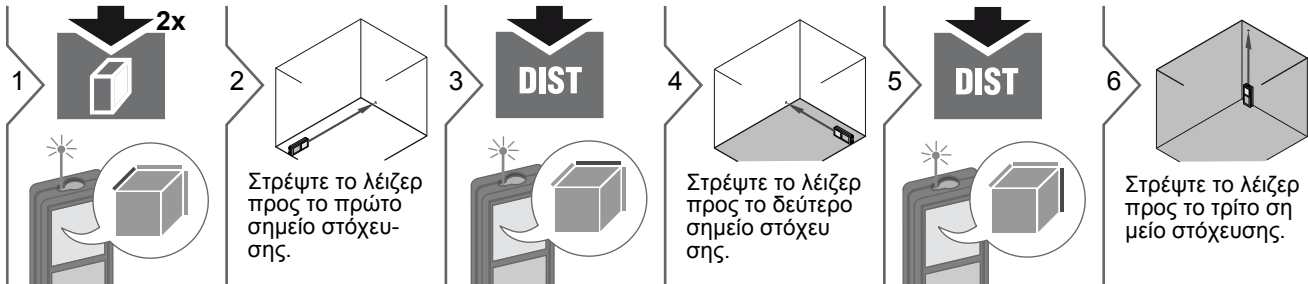

## Εμβαδόν τριγώνου

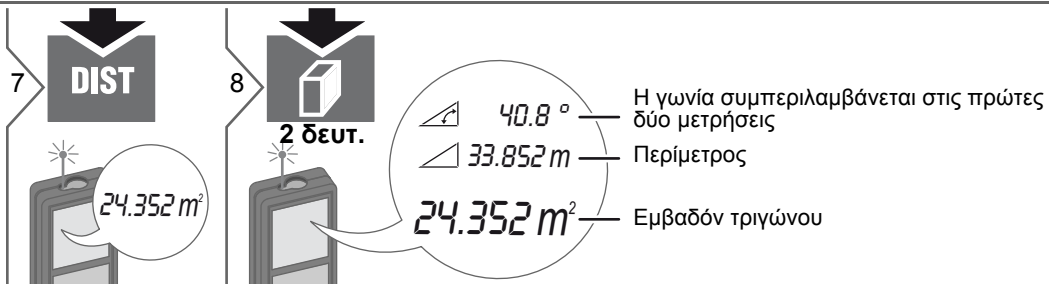
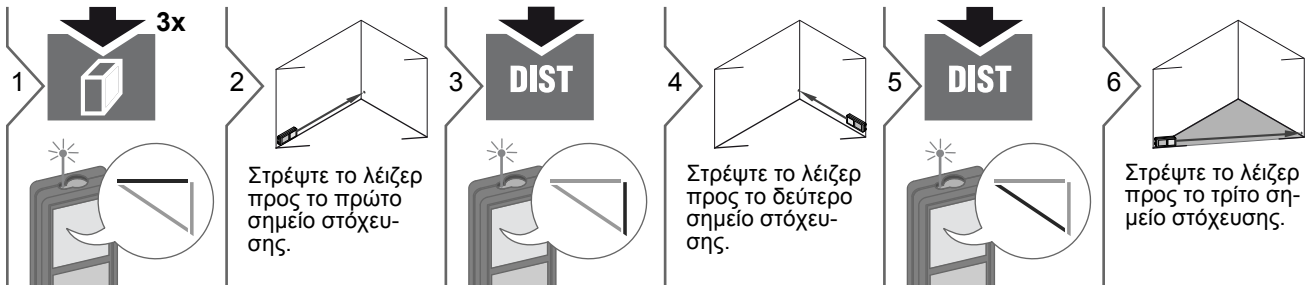

# Λειτουργίες μέτρησης

## Πυθαγόρας (2 σημεία)

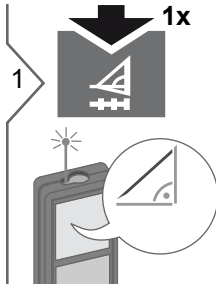

Στρέψτε το λέιζερ στο επάνω σημείο.



Στρέψτε το λέιζερ ορθογώνια στο κάτω σημείο.

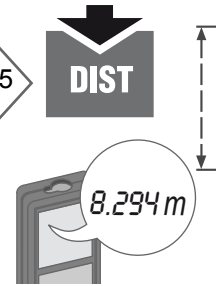

**i** Το αποτέλεσμα εμφανίζεται στην κεντρική γραμμή και η μετρηθείσα τιμή εμφανίζεται από πάνω. Πατώντας το πλήκτρο μέτρησης επί 2 δευτ. στη λειτουργία ενεργοποιείται αυτόματα η μέτρηση Ελάχιστης ή η Μέγιστης απόστασης.

## Πυθαγόρας (3 σημεία)

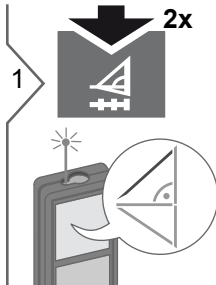

Στρέψτε το λέιζερ στο επάνω σημείο.



Στρέψτε το λέιζερ στο ορθογώνιο σημείο.



Στρέψτε το λέιζερ στο κάτω σημείο.

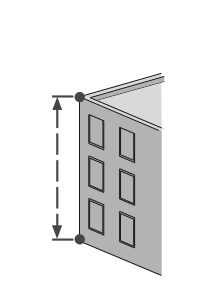
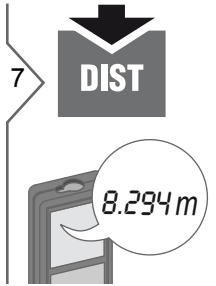

**i** Το αποτέλεσμα εμφανίζεται στην κεντρική γραμμή και η μετρηθείσα τιμή εμφανίζεται από πάνω. Πατώντας το πλήκτρο μέτρησης επί 2 δευτ. στη λειτουργία ενεργοποιείται αυτόματα η μέτρηση Ελάχιστης ή η Μέγιστης απόστασης.

# Λειτουργίες μέτρησης

## Πυθαγόρας (μερικό ύψος)

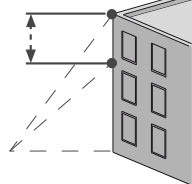
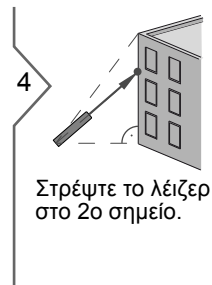
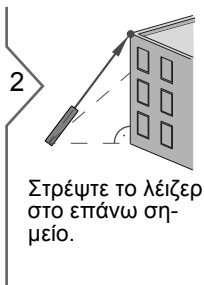
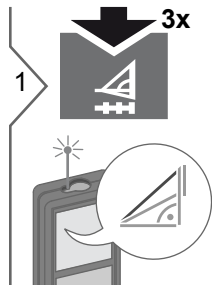

**i** Το αποτέλεσμα εμφανίζεται στην κεντρική γραμμή και η μετρηθείσα τιμή εμφανίζεται από πάνω. Πατώντας το πλήκτρο μέτρησης επί 2 δευτ. στη λειτουργία ενεργοποιείται αυτόματα η μέτρηση Ελάχιστης ή η Μέγιστης απόστασης.

# Λειτουργίες μέτρησης

## Χάραξη

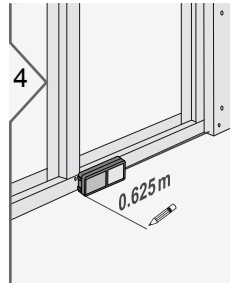
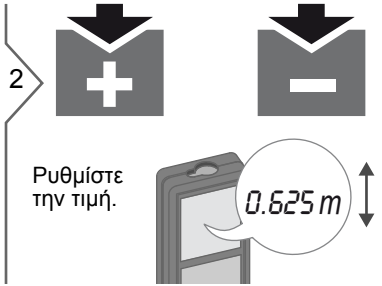
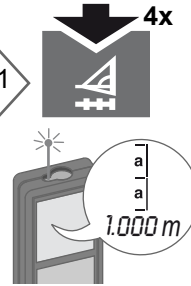
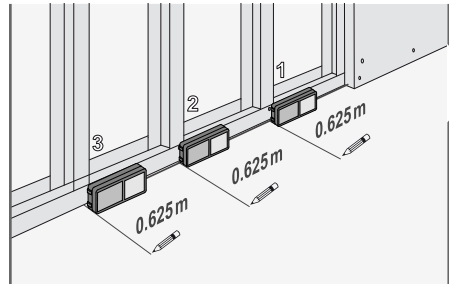

Μετακινήστε αργά τη συσκευή κατά μήκος της γραμμής χάραξης. Η απόσταση έως το επόμενο σημείο χάραξης εμφανίζεται στην οθόνη.

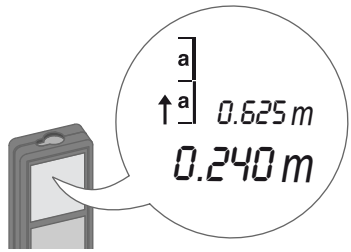

Λείπει η ένδειξη 0.240 m δίπλα στην απόσταση 0.625 m.

**i** Όταν πλησιάζετε στο σημείο χάραξης σε απόσταση μικρότερη του 0,1 m, από το όργανο αρχίζει να ακούγεται ένα μπιπι. Μπορείτε να διακόψετε τη λειτουργία πατώντας το κουμπί CLEAR/OFF.

## Έξυπνη οριζόντια λειτουργία

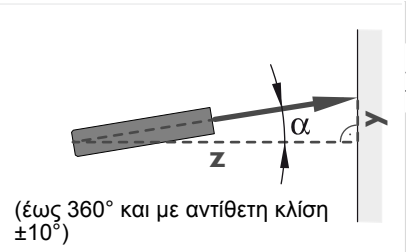
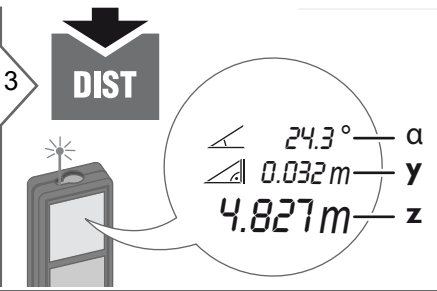
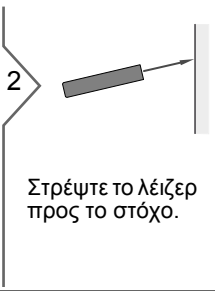
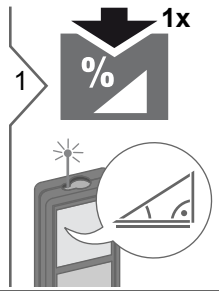

(έως 360° και με αντίθετη κλίση ±10°)

**i** Πατήστε το κλειδί ξανά για να τερματίσετε την οριζόντια μέτρηση.

## Ανίχνευση ύψους

Αυτή η λειτουργία εμφανίζει συνεχώς το ύψος ανίχνευσης εάν η συσκευή ενεργοποιηθεί πάνω σε τρίποδο. Δεν απαιτείται 2η μέτρηση απόστασης διότι μόνο η γωνία μετράται αυτόματα.

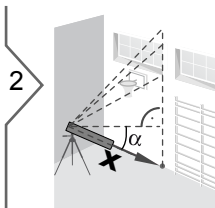
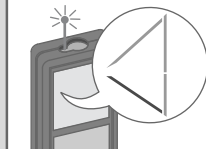
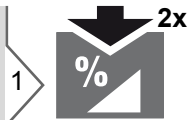

Στρέψτε το λέιζερ στο κάτω σημείο.

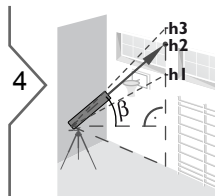

Στρέψτε το λέιζερ στα επάνω σημείο και η ανίχνευση γωνιάς/ύψους αρχίζει αυτόματα.

5

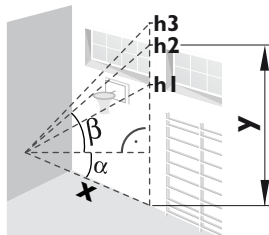
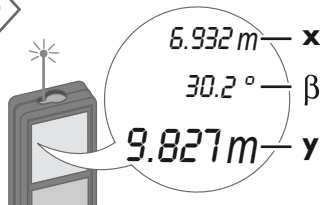

Το ύψος "y" που ανιχνεύεται είναι στις 90° σε σχέση με το 1ο στοχευμένο σημείο "x".

6



Σταματά την ανίχνευση ύψους και εμφανίζει την τελευταία μέτρηση.

## Οριζοντίωση

Αυτή η λειτουργία εμφανίζει διαρκώς την κλίση της συσκευής. Από κλίση  $\pm 5^\circ$ , η συσκευή αρχίζει να εκπέμπει σε τακτά διαστήματα έναν ήχο μπιπ. Όσο πλησιάζει στις  $0^\circ$  τόσο αυξάνεται η συχνότητα των μπιπ. Εάν φθάσει σε κλίση  $\pm 0.3^\circ$ , η συσκευή εκπέμπει ένα συνεχόμενο μπιπ.

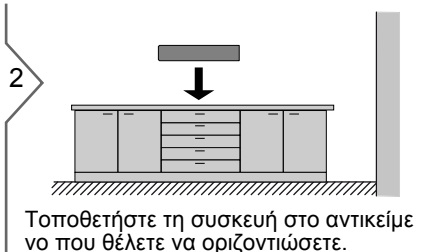
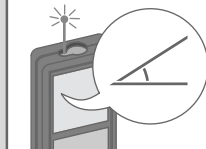
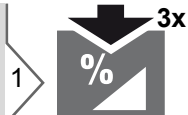

Τοποθετήστε τη συσκευή στο αντικείμενο που θέλετε να οριζοντιώσετε.

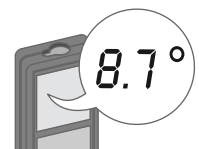

Εμφανίζεται η κλίση (εύρος  $\pm 180^\circ$ ).

## Λειτουργίες μέτρησης

### Μνήμη (20 τελευταίες ενδείξεις)

1



Εμφανίζονται οι 20 τελευταίες ενδείξεις.



2



Περιήγηση στις 20 τελευταίες ενδείξεις.

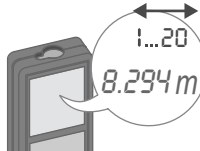



### Διαγραφή μνήμης

3



**2 δευτ.**





**2 δευτ. ταυτόχρονα**

Μπορείτε να χρησιμοποιήσετε την κεντρική γραμμή για περαιτέρω υπολογισμούς.

Η μνήμη διαγράφεται εντελώς.

## Βαθμονόμηση αισθητήρα κλίσης (Βαθμονόμηση κλίσης)

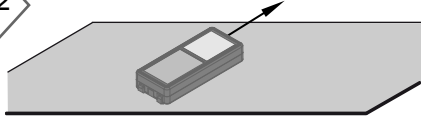

1  2 δευτ. ταυτόχρονα

 MEAS 1  
HOR  
CAL

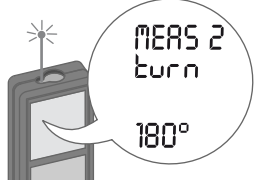
2  Τοποθετήστε τη συσκευή σε μια επίπεδη επιφάνεια.

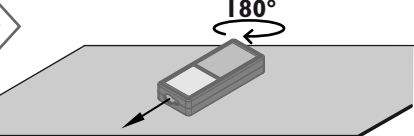
3   MEAS 2  
turn  
180°

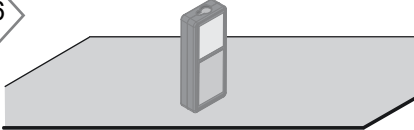

4  180°

5   MEAS 3  
VER  
CAL

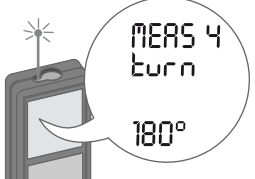
6  Γυρίστε τη συσκευή ανάποδα και τοποθετήστε την ξανά σε μια απόλυτα επίπεδη επιφάνεια.

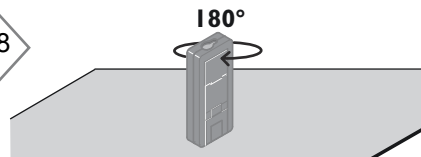
7   MEAS 4  
turn  
180°

8  180°

9   OK  
CAL

 Μετά από 2 δευτ. η συσκευή επιστρέφει στην κανονική λειτουργία.

# Τεχνικά χαρακτηριστικά

Μέτρηση απόστασης	
Τυπική ανοχή μέτρησης*	± 1.0 mm / 0.04 in ***
Μέγιστη ανοχή μέτρησης**	± 2.0 mm / 0.08 in ***
Εμβέλεια πλάκας στόχευσης	100 m / 330 ft
Τυπική εμβέλεια*	80 m / 262 ft
Εμβέλεια σε μη ευνοϊκές συνθήκες ****	60 m / 197 ft
Μικρότερη τιμή που εμφανίζεται	0.1 mm / 1/32 in
Ø κοκκίδας λέιζερ σε αποστάσεις	6 /30 / 60 mm (10 / 50 / 100 m)
Μέτρηση κλίσης	
Ανοχή μέτρησης έως την ακτίνα λέιζερ*****	± 0.2°
Ανοχή μέτρησης έως το κέλυφος*****	± 0.2°
Εμβέλεια*	360°
Γενικά	
Κατηγορία λέιζερ	2
Τύπος λέιζερ	635 nm, < 1 mW
Εκτροπή ακτίνας	0.16 x 0.6 mrad
Διάρκεια παλμού	0.2 x 10 <sup>-9</sup> s - 0.8 x 10 <sup>-9</sup> s
Κατηγορία προστασίας	IP54 (προστασία από σκόνη και πισίλισμα νερού)
Αυτόματη απενεργοποίηση λέιζερ	μετά από 90 δευτ.
Αυτόματη απενεργοποίηση λέιζερ	μετά από 180 δευτ.
Διάρκεια μπαταρίας (2 x AAA)	έως 5000 μετρήσεις
Διάσταση (Υ x Β x Π)	125.2 x 58 x 32.6 mm 4.9 x 2.3 x 1.3 in
Βάρος (με μπαταρίες)	154 g / 5.43 oz
Εύρος θερμοκρασιών:	
- Αποθήκευση	-25 έως 70 °C -13 έως 158 °F
- Λειτουργία	-10 έως 50 °C 14 έως 122 °F

\* ισχύει για 100 % ανακλαστικότητα στόχου (λευκός βαμμένος τοίχος), χαμηλό φωτισμό φόντου, 25 °C

\*\* ισχύει για 10 έως 500 % ανακλαστικότητα στόχου, υψηλό φωτισμό φόντου, - 10 °C έως + 50 °C

\*\*\* Ισχύουν ανοχές από 0,05 m έως 10 m με επίπεδο εμπιστοσύνης 95%. Η μέγιστη ανοχή μπορεί να μειωθεί στο 0.1 mm/m μεταξύ 10 m και 30 m και στο 0.2 mm/m για αποστάσεις πάνω από 30 m

\*\*\*\* ισχύει για 100 % ανακλαστικότητα στόχου, φωτισμό φόντου περίπου 30'000 lux

\*\*\*\*\* μετά τη βαθμονόμηση του χρήστη. Πρόσθετη απόκλιση σχετική με γωνία +/- 0,01° για κάθε μοίρα έως +/-45° σε κάθε τεταρτημόριο. Ισχύει για θερμοκρασία δωματίου Σε ολόκληρο το εύρος τιμών θερμοκρασίας, η μέγιστη απόκλιση αυξάνεται κατά +/- 0,1°.

i Για ακριβή έμμεσα αποτελέσματα, συνιστάται να χρησιμοποιείτε τρίποδο. Για ακριβείς μετρήσεις κλίσης, η αντίθετη κλίση πρέπει να αποφεύγεται.

Λειτουργίες	
Μέτρηση απόστασης	ναι
Μέτρηση ελάχιστης/μέγιστης απόστασης	ναι
Μόνιμη μέτρηση	ναι
Χάραξη	ναι
Πρόσθεση/Αφαίρεση	ναι
Εμβασδόν	ναι
Όγκος	ναι
Πυθαγόρας	2 σημείων, 3 σημείων, μερικό ύψος
Έξυπνη οριζόντια λειτουργία / Έμμεσο ύψος	ναι
Ανίχνευση ύψους	ναι
Οριζοντίωση	ναι
Μνήμη	20 ενδείξεις
Βεερ	ναι
Φωτιζόμενη σθόνη	ναι
Τελικό εξάρτημα πολλαπλών λειτουργιών	ναι

Εάν το μήνυμα **Error** (Σφάλμα) δεν εξαφανιστεί μετά από επανειλημμένες ενεργοποιήσεις της συσκευής, απευθυνθείτε στον αντιπρόσωπο.

Εάν εμφανιστεί το μήνυμα **InFo** μαζί με έναν αριθμό, πατήστε το κουμπί Clear και ακολουθήστε τις παρακάτω οδηγίες:

Αρ.	Αιτία	Διόρθωση
156	Εγκάρσια κλίση μεγαλύτερη από 10°	Κρατήστε το όργανο χωρίς να σχηματίζει εγκάρσια κλίση.
162	Σφάλμα βαθμονόμησης	Βεβαιωθείτε ότι η συσκευή βρίσκεται σε μια απολύτως οριζόντια και επίπεδη επιφάνεια. Επαναλάβετε τη διαδικασία βαθμονόμησης. Εάν το σφάλμα επαναλαμβάνεται, απευθυνθείτε στον αντιπρόσωπο της περιοχής σας.
204	Σφάλμα υπολογισμού	Πραγματοποιήστε τη μέτρηση ξανά.
252	Θερμοκρασία πολύ υψηλή.	Αφήστε τη συσκευή να κρυώσει.
253	Θερμοκρασία πολύ χαμηλή	Ζεστάνετε τη συσκευή.
255	Σήμα λήψης πολύ ασθενές, ο χρόνος μέτρησης πολύ μεγάλος	Αλλάξτε την επιφάνεια στόχευσης (π.χ. λευκό χαρτί).
256	Σήμα λήψης πολύ υψηλό	Αλλάξτε την επιφάνεια στόχευσης (π.χ. λευκό χαρτί).
257	Πολύ έντονο φως στο φόντο	Η επιφάνεια στόχευσης πρέπει να είναι πιο σκοτεινή.
258	Η μέτρηση βρίσκεται εκτός εμβέλειας	Διορθώστε την εμβέλεια.
260	Η ακτίνα λέιζερ διακόπτεται	Επαναλάβετε τη μέτρηση.

## Φροντίδα

- Καθαρίστε τη συσκευή με ένα υγρό, μαλακό πανί.
- Ποτέ μη βυθίζετε τη συσκευή στο νερό.
- Ποτέ μη χρησιμοποιείτε καθαριστικούς παράγοντες ή διαλυτικά.

## Εγγύηση

### Ευρώπη:

- Εγγύηση επιστροφής σε περίπτωση μη ικανοποίησης εντός 30 ημερών
  - Δωρεάν σέρβις για ένα έτος
  - Πλήρης εγγύηση ενός έτους
- Μπορείτε να βρείτε λεπτομερείς πληροφορίες στο Διαδίκτυο στη διεύθυνση [www.2helpU.com](http://www.2helpU.com).

### Βόρεια Αμερική:

- 3ετής περιορισμένη εγγύηση
- Δωρεάν σέρβις για ένα έτος
- Εγγύηση επιστροφής χρημάτων 90 ημερών

Μπορείτε να βρείτε λεπτομερείς πληροφορίες στο Διαδίκτυο στη διεύθυνση [www.dewalt.com](http://www.dewalt.com).

## Οδηγίες ασφαλείας

Ο υπεύθυνος του οργάνου πρέπει να διασφαλίσει ότι όλοι οι χρήστες κατανοούν και τηρούν αυτές τις οδηγίες.

### Τομείς ευθύνης

#### Τομέας ευθύνης του κατασκευαστή του γνήσιου εξοπλισμού:

Ευρώπη:  
DEWALT  
D-65510 Idstein, Germany  
[www.2helpU.com](http://www.2helpU.com)  
[www.dewalt.eu](http://www.dewalt.eu)

Βόρεια Αμερική:  
DEWALT Industrial Tool Co.  
Baltimore, MD21286, USA  
Για σέρβις, καλέστε 1-800-4-DEWALT.  
[www.dewalt.com](http://www.dewalt.com)

Η παραπάνω εταιρεία είναι υπεύθυνη για την παράδοση του προϊόντος, μαζί με το εγχειρίδιο χρήσης, σε άριστη ως προς την ασφάλεια κατάσταση. Η παραπάνω εταιρεία δεν ευθύνεται για τα αξεσουάρ τρίτων κατασκευαστών.

#### Τομέας ευθύνης του κατόχου:

- Να κατανοήσει τις οδηγίες ασφαλείας στο προϊόν και τις οδηγίες στο εγχειρίδιο χρήσης.
- Να εξοικειωθεί με τους τοπικούς κανονισμούς ασφαλείας περί πρόληψης ατυχημάτων.
- Να αποτρέπει πάντοτε την πρόσβαση στο προϊόν από μη εξουσιοδοτημένο προσωπικό.

## Οδηγίες ασφαλείας

### Επιτρεπόμενη χρήση

- Μέτρηση αποστάσεων
- Μέτρηση κλίσης

### Μη επιτρεπόμενη χρήση

- Χρήση του προϊόντος χωρίς οδηγίες
- Χρήση εκτός των αναφερόμενων ορίων
- Απενεργοποίηση των συστημάτων ασφαλείας και αφαίρεση των επεξηγηματικών και προειδοποιητικών πινακίδων
- Άνοιγμα του εξοπλισμού με εργαλεία (κατσαβίδια, κ.λπ.)
- Πραγματοποίηση τροποποιήσεων ή μετατροπών του προϊόντος
- Χρήση αξεσουάρ από άλλους κατασκευαστές χωρίς ρητή έγκριση
- Σκόπιμη θάμβωση τρίτων, ακόμη και στο σκοτάδι
- Ανεπαρκής ασφάλιση του χώρου μετρήσεων (π.χ. κατά τις μετρήσεις σε δρόμους, εργοτάξια, κ.λπ.)
- Συνειδητός ή απερίσκεπτος χειρισμός πάνω σε ικρίωματα, σε σκάλες, κατά τη μέτρηση κοντά σε μηχανήματα που λειτουργούν ή σε ανοικτά εξαρτήματα μηχανημάτων ή εγκαταστάσεων που δεν προστατεύονται.
- Άμεση στόχευση στον ήλιο

### Κίνδυνοι κατά τη χρήση

#### ΠΡΟΕΙΔΟΠΟΙΗΣΗ

Προσέχετε για τυχόν εσφαλμένες μετρήσεις εάν το όργανο είναι ελαττωματικό ή εάν έχει πέσει κάτω ή εάν έχει τύχει πλημμελούς χρήσης ή εάν έχει τροποποιηθεί. Ανά διαστήματα πραγματοποιείτε δοκιμαστικές μετρήσεις.

Ίδιως μετά από ακατάλληλη χρήση του οργάνου, και πριν, στη διάρκεια και μετά από σημαντικές μετρήσεις.

#### ΠΡΟΣΟΧΗ

Ποτέ μην επιχειρήσετε να επισκευάσετε το προϊόν εσείς οι ίδιοι. Σε περίπτωση ζημιάς, απευθυνθείτε στον τοπικό αντιπρόσωπο.

#### ΠΡΟΕΙΔΟΠΟΙΗΣΗ

Τυχόν αλλαγές ή τροποποιήσεις που δεν είναι ρητά εγκεκριμένες μπορεί να αφαιρέσουν από το χρήστη τη δυνατότητα να χρησιμοποιηθεί τον εξοπλισμό.

#### Περιορισμοί χρήσης

 Βλ. ενότητα "Τεχνικά χαρακτηριστικά".

Η συσκευή έχει σχεδιαστεί για χρήση σε περιοχές μόνιμα κατοικήσιμες από ανθρώπους. Μη χρησιμοποιείτε το προϊόν σε περιβάλλον που ενέχει κίνδυνο έκρηξης ή σε επικίνδυνο περιβάλλον.

### Απόρριψη

#### ΠΡΟΣΟΧΗ

Οι άδειες μπαταρίες δεν πρέπει να απορρίπτονται μαζί με τα οικιακά απορρίμματα. Φροντίστε το περιβάλλον και μεταφέρετέ τις σε σημεία αποκομιδής σύμφωνα με τους εθνικές ή τοπικές κανονισμούς.

Το προϊόν δεν πρέπει να απορρίπτεται μαζί με τα οικιακά απορρίμματα.

Φροντίστε για την κατάλληλη απόρριψη του προϊόντος σύμφωνα με τις εθνικές διατάξεις που ισχύουν στη χώρα σας.

Τηρείτε τις εθνικές διατάξεις διάθεσης απορριμμάτων.

Πληροφορίες για την επεξεργασία του προϊόντος και τη διαχείριση αποβλήτων μπορείτε να κατεβάσετε από την ιστοσελίδα μας.

#### Ηλεκτρομαγνητική συμβατότητα (ΗΜΣ)

#### ΠΡΟΕΙΔΟΠΟΙΗΣΗ

Η συσκευή πληροί τις πλέον αυστηρές απαιτήσεις των σχετικών προτύπων και διατάξεων.

Ωστόσο, η πιθανότητα να προκαλέσει παρεμβολές σε άλλες συσκευές δεν μπορεί να αποκλειστεί εντελώς.



## Κατηγορία λέιζερ

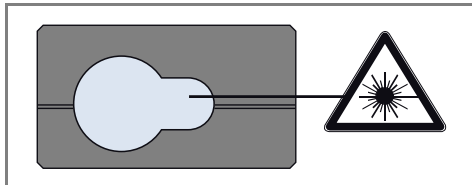

Η συσκευή δημιουργεί ορατές ακτίνες λέιζερ, που εκπέμπονται από το όργανο. Πρόκειται για προϊόν κατηγορίας λέιζερ 2 σύμφωνα με:

- IEC60825-1 : 2007 "Ασφάλεια ακτινοβολίας προϊόντων λέιζερ"

### Προϊόντα λέιζερ κατηγορίας 2:

Μην κοιτάζετε κατευθείαν την ακτίνα λέιζερ και μην τη στρέφετε χωρίς λόγο προς άλλα άτομα. Συνήθως τα μάτια προστατεύονται όταν το πρόσωπο στρέφεται αυτόματα προς την αντίθετη κατεύθυνση ή με το ανοιγοκλείσιμο των ματιών.

### **⚠️ ΠΡΟΕΙΔΟΠΟΙΗΣΗ**

Εάν κοιτάξετε κατευθείαν στην ακτίνα λέιζερ με οπτικά βοηθήματα (π.χ. κιάλια, τηλεσκόπιο) μπορεί να αποβεί επικίνδυνο.

### **⚠️ ΠΡΟΣΟΧΗ**

Εάν κοιτάξετε στην ακτίνα λέιζερ, αυτό μπορεί να είναι επικίνδυνο για τα μάτια.

## Πινακίδες

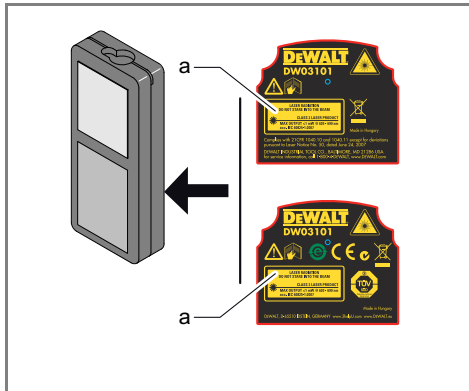

Κολλήστε την αυτοκόλλητη ετικέτα λέιζερ (a) με την εθνική σας γλώσσα.

## İçindekiler

<b>Cihazın Kurulumu</b> .....	<b>2</b>
Giriş .....	2
Genel bakış .....	2
Ekran .....	3
Pillerin takılması .....	3
<b>İşlemler</b> .....	<b>4</b>
Açma/Kapama İşlemi .....	4
Silme .....	4
Mesaj Kodları .....	4
Ölçüm referansının ayarlanması / üçayak .....	4
Çok işlevsel uç parça .....	5
Mesafe birimi ayarı .....	5
Eğim birimi ayarı .....	5
Zamanlayıcı (otomatik-serbest bırakma) .....	5
Bip Açık/Kapalı .....	6
Işık Açık/Kapalı .....	6
<b>Ölçüm İşlevleri</b> .....	<b>7</b>
Münferit mesafe ölçümü .....	7
Kesintisiz / Minimum-Maksimum ölçüm .....	7
Ekleme / Çıkarma .....	7
Alan .....	8
Hacim .....	9
Üç köşeli alan .....	10
Pisagor (2 noktalı) .....	11
Pisagor (3 noktalı) .....	11
Pisagor (kısmi yükseklik) .....	12
İşaretleme .....	13
Akıllı Yatay Mod .....	13
Yükseklik izleme .....	14
Tesviye .....	14
Bellek (son 20 gösterim) .....	15

Bellek Silme .....	15
--------------------	----

## **Kalibrasyon** .....

Eğim sensörünün ayarlanması (Eğim Kalibrasyonu) .....	16
---	----

## **Teknik Veriler** .....

## **Mesaj Kodları** .....

## **Bakım** .....

## **Garanti** .....

## **Emniyet Talimatnamesi** .....

Sorumluluk Alanları .....	18
Cihazın uygun kullanım şekilleri .....	19
Aykırı kullanım .....	19
Kullanırken Ortaya Çıkabilecek Tehlikeler .....	19
Kullanım Alanı Sınırları .....	19
Elden çıkarma .....	19
Elektromanyetik Uyumluluk (EMC) .....	19
Lazer Sınıfı .....	20
Etiket Yazıları .....	20

## Giriş

 İlk kullanımdan önce, güvenlik talimatlarının ve kullanma kılavuzunun dikkatle okunması gerekmektedir.

 Üründen sorumlu kişinin, tüm kullanıcıların ilgili yönergeleri anladığından ve uyguladığından emin olması gerekmektedir.

Kullanılan simgelerin anlamları aşağıda açıklanmıştır:

### UYARI

Potansiyel olarak tehlikeli bir duruma veya dikkat edilmez ise, ölüme ya da ciddi yaralanmaya yol açabilecek türden amaç dışı kullanıma dikkati çeker.

### DİKKAT

Potansiyel olarak tehlikeli bir duruma veya dikkat edilmez ise, hafif yaralanmalara ve/veya malzeme, finans ve çevre açısından zarara yol açabilecek türden amaç dışı kullanıma dikkati çeker.

 Ürünün, teknik olarak doğru ve verimli bir şekilde kullanılabilmesi için, kullanıcıya yardımcı olacak kullanım bilgileri.

## Genel bakış



# Cihazın Kurulumu

## Ekran

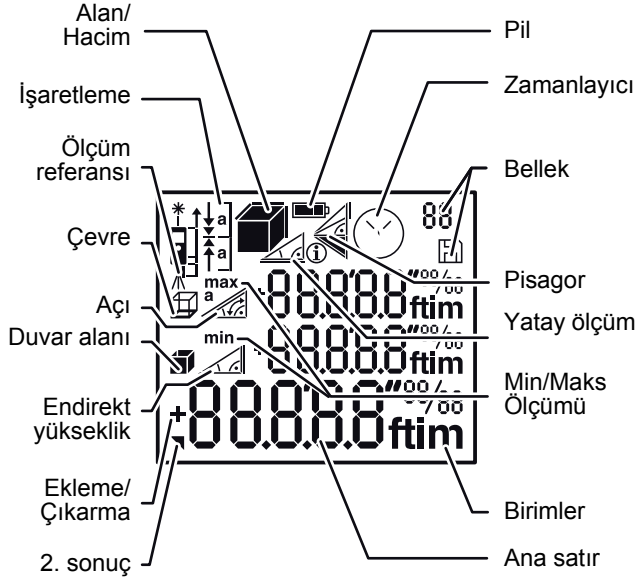

## Pillerin takılması

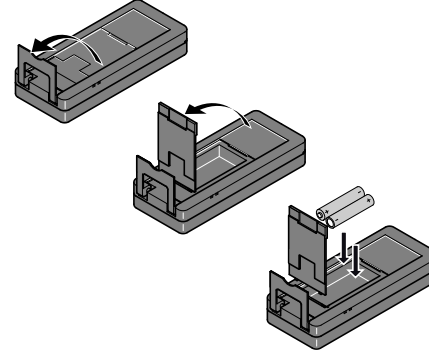

i

Güvenilir bir kullanım sağlamak için, çinko-karbon pilleri kullanmayın. Pil simgesi yanıp söndüğünde pilleri değiştirin.



## Açma/Kapama İşlemi

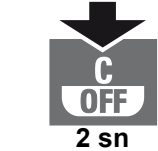

Cihaz kapanır.

**i** Sürekli lazer modunu başlatmak için açma düğmesine 2 sn süreyle basın. 180 sn boyunca hiçbir tuşa basılmazsa cihaz otomatik olarak kapanır.

## Silme

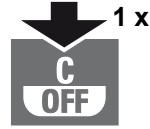

Son eylemi geri alır.

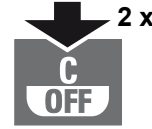

Süren işlevi bırakır, varsayılan işletim moduna gider.

## Mesaj Kodları

Bir sayıyla birlikte bilgi simgesi görüntülenirse, "Mesaj Kodları" bölümündeki talimatları takip edin.  
Örnek:



## Ölçüm referansının ayarlanması / üçayak

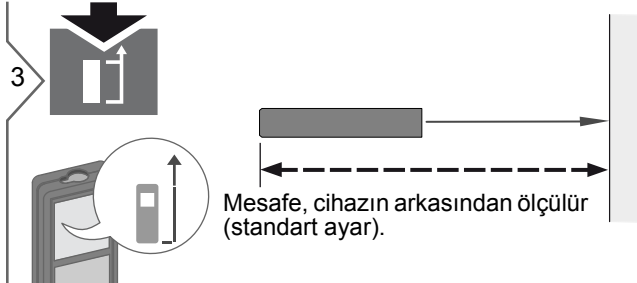
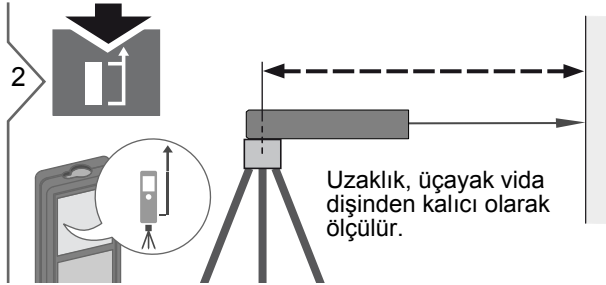
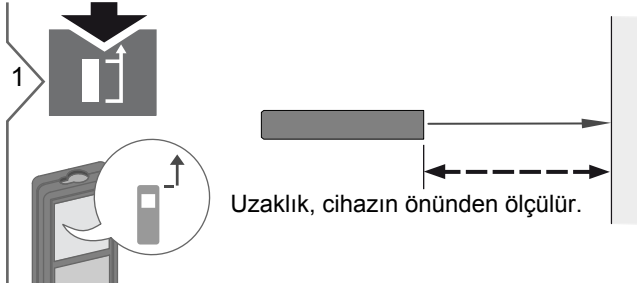

## İşlemler

### Çok işlevsel uç parça

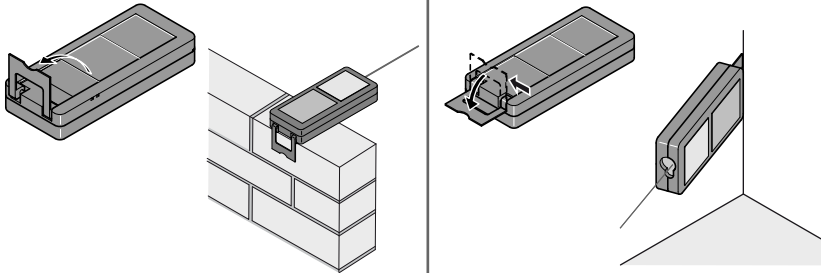

**i** Uç parçanın yönelimi otomatik olarak saptanır ve sıfır noktası buna göre ayarlanır.

### Mesafe birimi ayarı



2 sn

Aşağıdaki birimler arasında geçiş sağlar:

0.000 m	0.00 ft
0.0000 m	0'00" 1/32
0.00 m	0.00 in
	0 in 1/32

### Eğim birimi ayarı



aynı anda 2 sn

Aşağıdaki birimler arasında geçiş sağlar:

180 °
0.0 %

### Zamanlayıcı (otomatik-serbest bırakma)

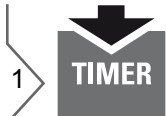

Otomatik serbest bırakma gecikmesini ayarlayın (maks. 60 sn., standart ayar 5 sn.)

**i** Lazer çalıştırıldığında ve tuş serbest bırakılınca, ölçüme kadar olan kalan saniyeler geri sayım sırasında görüntülenir. Gecikmeli serbest bırakma, örn. uzun mesafelerde kesin hedefleme için önerilir. Ölçüm tuşuna basılırken cihazın sallanmasını önler.

**İşlemler****Bip Açık/Kapalı**

aynı anda 2 sn

**Işık Açık/Kapalı**

aynı anda 2 sn

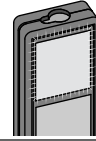

## Ölçüm İşlemleri

### Münferit mesafe ölçümü

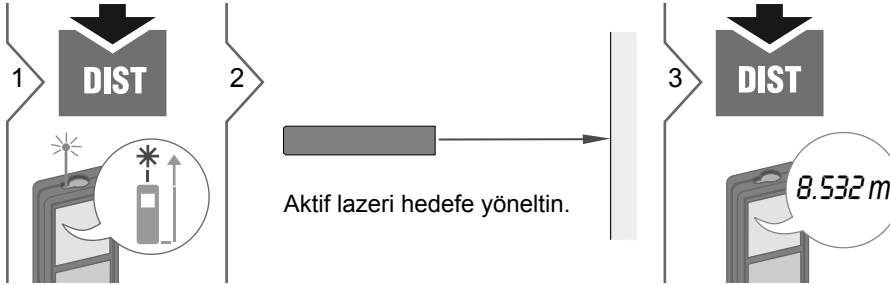

**i** Hedef yüzeyler: Renksiz sıvalara, cama, suni köpük ya da yarı geçirgen yüzeylere doğru ölçüm alınırken veya çok parlak yüzeyler hedef alındığında ölçüm hataları meydana gelebilir. Karanlık yüzeylerde, ölçüm süresi artar.

### Kesintisiz / Minimum-Maksimum ölçüm

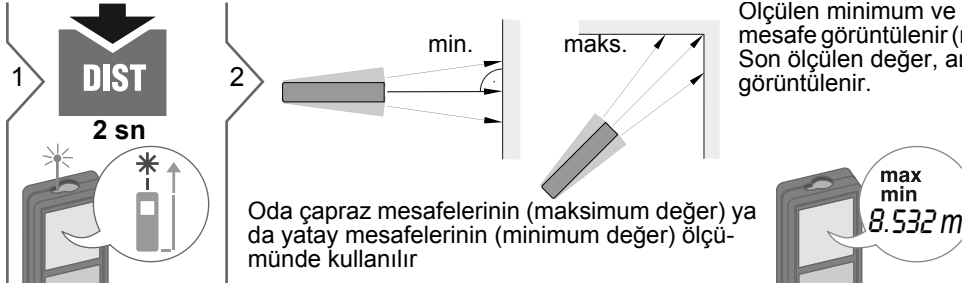

Kesintisiz / minimum-maksimum ölçümü durdurur.

### Ekleme / Çıkarma

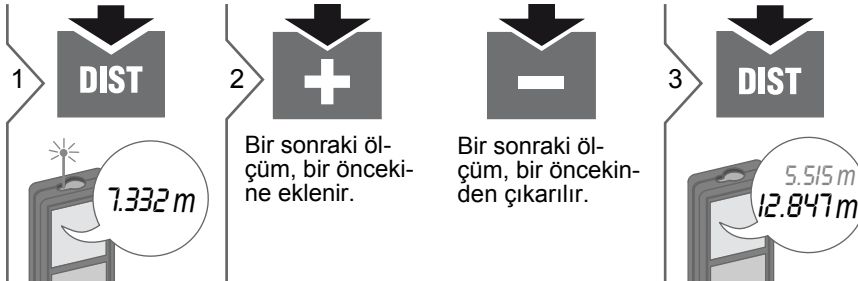

**i** Sonuç, ana satırda; ölçülen değer ise üzerinde görüntülenir. Bu prosedür, işlem tamamlanıncaya kadar tekrarlanabilir. Aynı işlem, alanlar veya hacimlerin toplanması veya çıkarılması için de kullanılabilir.

# TR Ölçüm İşlevleri

## Alan

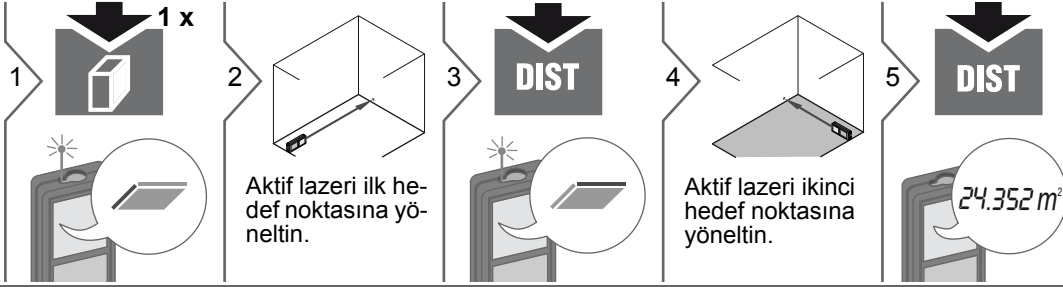

i

Sonuç, ana satırda; ölçülen değer ise üzerinde görüntülenir.

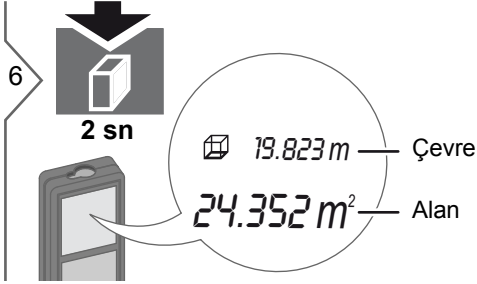

# Ölçüm İşlevleri

## Hacim

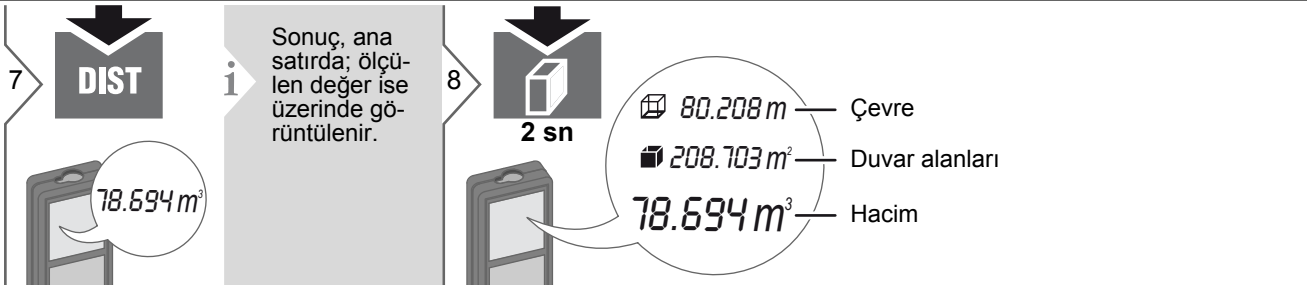
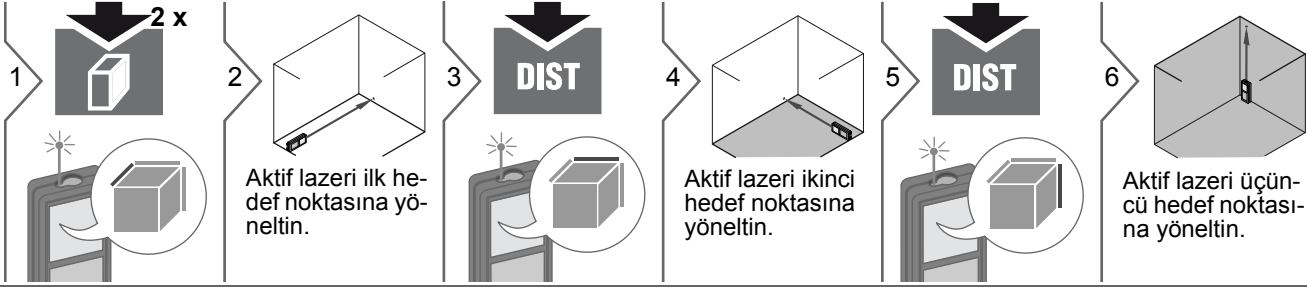

## Ölçüm İşlevleri

## Üç köşeli alan

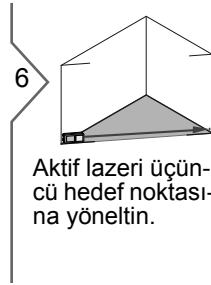
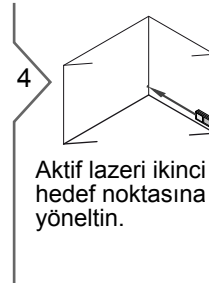
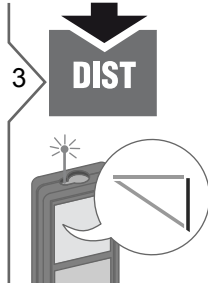
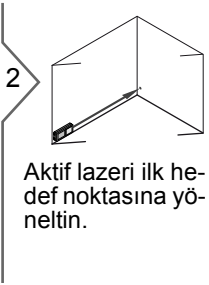
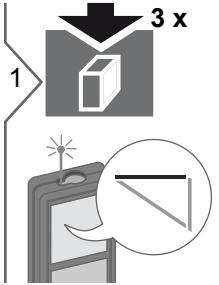

40.8 °

İlk iki ölçüme eklenen açı



33.852 m

Çevre

24.352 m<sup>2</sup>

Üç köşeli alan

## Ölçüm İşlevleri

### Pisagor (2 noktalı)

1  1 x

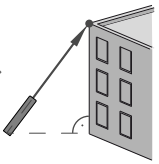
2  Lazeri yukarıdaki noktaya yöneltin.

3  DIST

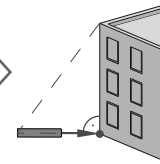
4  Lazeri dik açıyla aşağıdaki noktaya yöneltin.

5  DIST

8.294 m

**i** Sonuç, ana satırda; ölçülen mesafe ise üzerinde görüntülenir. İşlev sırasında ölçüm tuşuna 2 sn süreyle basılırsa, Minimum veya Maksimum ölçüm otomatik olarak etkinleşir.

### Pisagor (3 noktalı)

1  2 x

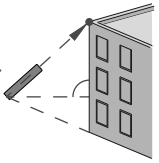
2  Lazeri yukarıdaki noktaya yöneltin.

3  DIST

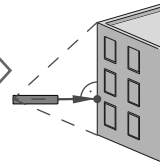
4  Lazeri dik açı ya-pacak şekilde yöneltin.

5  DIST

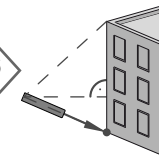
6  Lazeri aşağıdaki noktaya yöneltin.

7  DIST

8.294 m

**i** Sonuç, ana satırda; ölçülen mesafe ise üzerinde görüntülenir. İşlev sırasında ölçüm tuşuna 2 sn süreyle basılırsa, Minimum veya Maksimum ölçüm otomatik olarak etkinleşir.

# Ölçüm İşlemleri

## Pisagor (kısmi yükseklik)

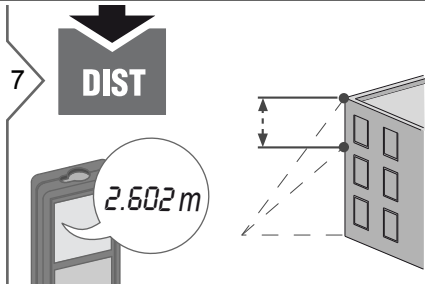
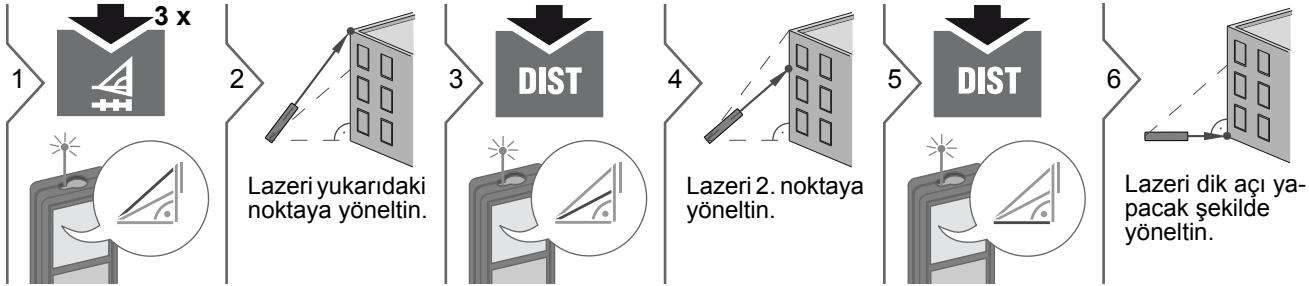

**i**  
Sonuç, ana satırda; ölçülen mesafe ise üzerinde görüntülenir. İşlev sırasında ölçüm tuşuna 2 sn süreyle basılırsa, Minimum veya Maksimum ölçüm otomatik olarak etkinleşir.

## Ölçüm İşlevleri

### İşaretleme

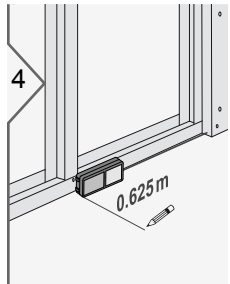
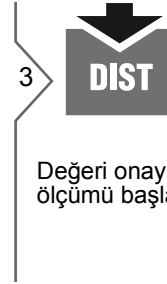
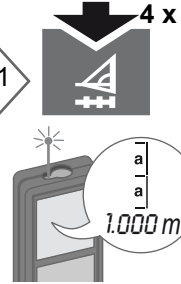
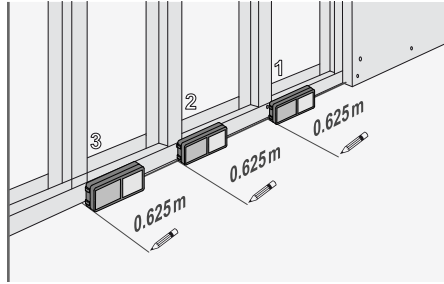

Cihazı, işaretleme çizgisi boyunca yavaşça hareket ettirin. Sonraki işaretleme noktasına olan mesafe görüntülenir.

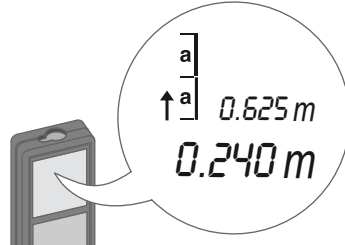

Bir sonraki 0,625 m'lik mesafeye 0,240 m kaldı.

**i** Bir işaretleme noktasına 0,1 m'den daha fazla yaklaşıldığında cihazdan "bip" ikaz sesi duyulmaya başlar. Bu işlev, SİLME/KAPATMA (CLEAR/OFF) düğmesine basarak durdurulabilir.

### Akıllı Yatay Mod

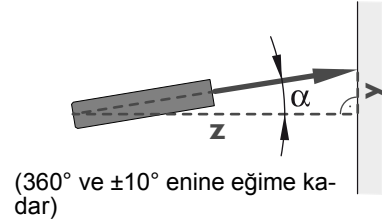
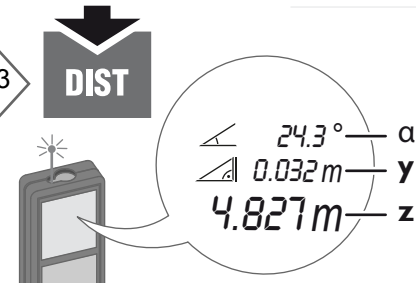
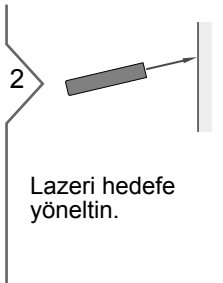
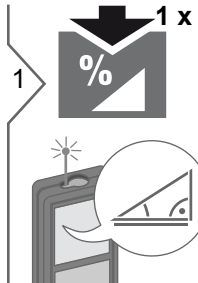

**i** Yatay ölçüm işlevini devre dışı bırakmak için tekrar düğmeye basın.

# Ölçüm İşlevleri

## Yükseklik izleme

Bu işlev, cihazın bir üçayak üzerinde açık konuma getirilmesi durumunda sürekli olarak izleme yüksekliğini gösterir. Yalnızca açı otomatik olarak ölçüldüğünden, 2. mesafe ölçümüne gerek yoktur.

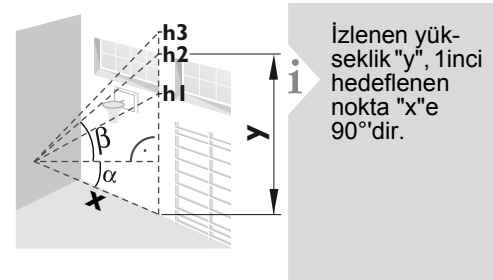
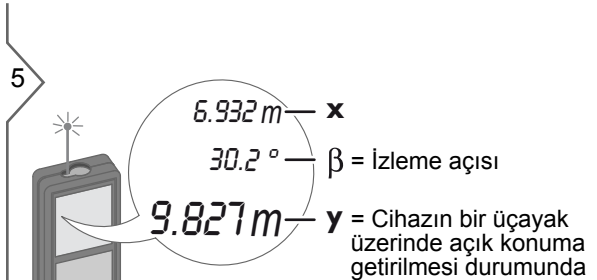
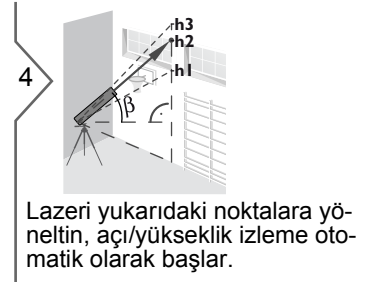
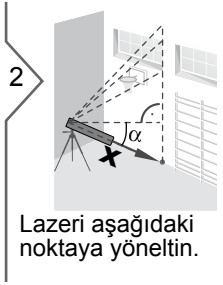
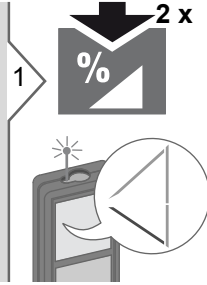

## Tesviye

Bu işlev, cihazın eğimini sürekli olarak görüntüler. ±5°'lik bir eğimden itibaren cihaz sık bir "bip" ikazı vermeye başlar. 0°'ye yaklaştıkça "bip" ikazı hızlanmaya başlar. ±0.3°'lik bir eğime ulaşıldığında cihaz sürekli "bip" ikazı verir.

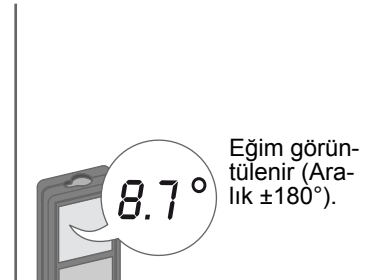
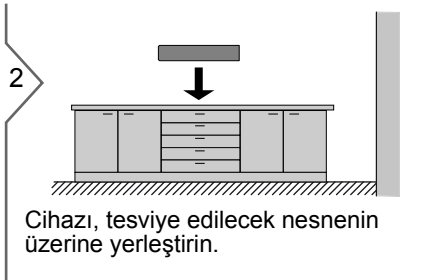
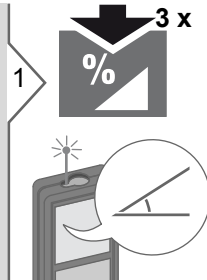

## Ölçüm İşlevleri

### Bellek (son 20 gösterim)

1



Son 20 gösterim görüntülenir.



1...20  
8.294 m

2



Son 20 gösterim arasında gezinir.

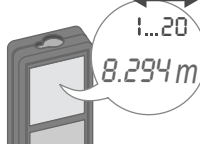

1...20  
8.294 m

3



**2 sn**

Ana satırdaki değer sonraki hesaplamalarda kullanılabilir.

### Bellek Silme

3



**aynı anda 2 sn**

Bellek tamamen silinir.

## Eğim sensörünün ayarlanması (Eğim Kalibrasyonu)

1  aynı anda 2 sn

MEAS 1 HOR  
CAL

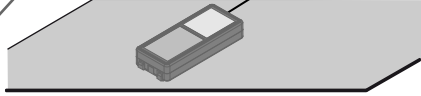
2  Cihazı tam olarak düz bir zemin üzerine yerleştirin.

3  MEAS 2 turn  
180°

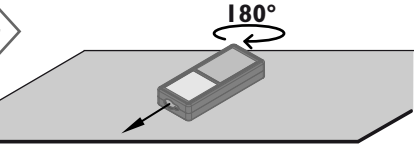
4  Cihazı yatay olarak 180° döndürün ve tekrar tam olarak düz bir zemin üzerine yerleştirin.

5  MEAS 3 VER  
CAL

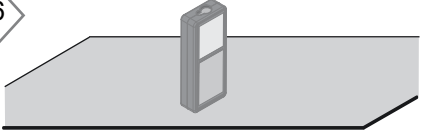
6  Cihazı baş aşağı çevirin ve tekrar tamamen düz bir zemin üzerine yerleştirin.

7  MEAS 4 turn  
180°

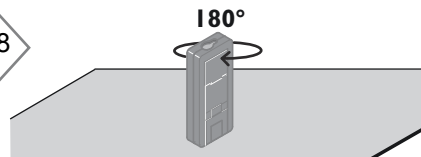
8  Cihazı yatay olarak 180° döndürün ve tekrar tam olarak düz bir zemin üzerine yerleştirin.

9  OK  
CAL

2 sn. sonra cihaz normal moda geri döner.

Mesafe ölçümü	
Tipik Ölçüm Toleransı *	± 1.0 mm / 0.04 in ***
Maksimum Ölçüm Toleransı **	± 2.0 mm / 0.08 in ***
Hedef plakasının erimi	100 m / 330 ft
Tipik Erim*	80 m / 262 ft
Elverişsiz koşullarda erim ****	60 m / 197 ft
Görüntülenen en küçük birim	0.1 mm / 1/32 in
Ø lazer noktası mesafelerde	6 /30 / 60 mm (10 / 50 / 100 m)
Eğim ölçümü	
Lazer ışını için ölçüm toleransı*****	± 0.2°
Mahfaza için ölçüm toleransı*****	± 0.2°
Erim	360°
Genel	
Lazer sınıfı	2
Lazer türü	635 nm, < 1 mW
Işın sapması	0.16 x 0.6 mrad
Darbe süresi	0.2 x 10 <sup>-9</sup> s - 0.8 x 10 <sup>-9</sup> s
Koruma sınıfı	IP54 (toza ve sıçrayan suya karşı korumalı)
Otomatik lazer kapama	90 sn sonra
Otomatik güç kapama	180 sn sonra
Pil ömrü (2 x AAA)	5000 ölçüm işlemine kadar
Boyutlar (Y x D x G)	125.2 x 58 x 32.6 mm 4.9 x 2.3 x 1.3 in
Ağırlık (piller ile birlikte)	154 g / 5.43 oz
Sıcaklık aralığı:	
- Saklama koşulları	-25 ila 70 °C -13 ila 158 °F
- İşletim	-10 ila 50 °C 14 ila 122 °F

\* %100 hedef yansıtıcılığı (beyaz boyalı duvar), düşük arılan aydınlatması, 25 °C için geçerlidir

\*\* %10 ila 500 hedef yansıtıcılığı, yüksek arılan aydınlatması, - 10 °C ila + 50 °C için geçerlidir

\*\*\* Toleranslar, %95 güven düzeyi ile 0.05 m ile 10 m arasında geçerlidir. Maksimum tolerans, 10 m ile 30 m arasında 0.1 mm/m'ye ve 30 m'nin üzerindeki uzaklıklar için 0.2 mm/m'ye düşebilir

\*\*\*\* %100 hedef yansıtıcılığı, yaklaşık 30'000 lüks arılan aydınlatması için geçerlidir

\*\*\*\*\* kullanıcı kalibrasyonundan sonra. Kadran başına +/-45°'ye kadar, derece başına +/- 0.01° ek açısal sapma. Oda sıcaklığında geçerlidir. Tüm çalıştırma sıcaklığı aralığı için, maksimum sapma +/- 0,1° olarak artış gösterir.

i Hassas dolaylı sonuçlar için bir üçayağın kullanımı önerilmektedir. Hassas eğim ölçümleri için enine eğimden kaçınılmalıdır.

İşlevler	
Mesafe ölçümü	evet
Min/Maks ölçümü	evet
Kesintisiz ölçüm	evet
İşaretleme	evet
Ekleme/Çıkarma	evet
Alan	evet
Hacim	evet
Pisagor	2 noktalı, 3 noktalı, kısmi yükseklik
Akıllı Yatay Mod / Endirekt yükseklik	evet
Yükseklik izleme	evet
Tesviye	evet
Bellek	20 gösterim
“Bip“ ikazı	evet
Işıklı ekran	evet
Çok işlevsel uç parça	evet

## Mesaj Kodları

Cihazın birden fazla defa açılmasına karşın **Error** (Hata) mesajı görünmezse bayinize başvurun.

Bir sayıyla birlikte **InFo** mesajı görüntülenirse, Silme düğmesine basın ve aşağıdaki talimatları takip edin:

No.	Nedeni	Düzeltilme İşlemi
156	10° değerinden daha büyük çapraz eğim	Cihazı çapraz eğimsiz tutun.
162	Kalibrasyon hatası	Cihazın tam olarak yatay ve düz bir zemin üzerine yerleştirildiğinden emin olun. Kalibrasyon işlemini tekrarlayın. Hata tekrar meydana gelirse bayinizle görüşün.
204	Hesaplama hatası	Ölçümü tekrarlayın.
252	Sıcaklık çok yüksek	Cihazı soğutun.
253	Sıcaklık çok düşük	Cihazı ısıtın.
255	Alınan sinyal çok zayıf, ölçüm süresi çok uzun	Hedef yüzeyi değiştirin (örneğin, beyaz kağıt).
256	Alınan sinyal çok yüksek	Hedef yüzeyi değiştirin (örneğin, beyaz kağıt).
257	Artalan ışığı çok fazla	Hedef alana gölge yapın.
258	Ölçüm aralığı dışında ölçüm	Aralığı düzeltin.
260	Lazer ışığında kesintiler oluşuyor	Ölçümü tekrarlayın.

## Bakım

- Cihazı nemli, yumuşak bir bezle temizleyin.
- Cihazı asla suya sokmayın.
- Agresif temizleyici veya çözücü maddeleri kesinlikle kullanmayın.

## Garanti

### Avrupa:

- 30 gün süreli risksiz memnuniyet garantisi
- Bir yıl süreyle ücretsiz servis
- Bir yıl süreli tam garanti

Ayrıntılı bilgilere internet üzerinden [www.2helpU.com](http://www.2helpU.com) adresinden ulaşılabilir.

### Kuzey Amerika:

- Üç yıl süreli sınırlı garanti
- Bir yıl süreyle ücretsiz servis
- 90 gün süreli para iade garantisi

Ayrıntılı bilgilere internet üzerinden [www.dewalt.com](http://www.dewalt.com) adresinden ulaşılabilir.

## Emniyet Talimatnamesi

Bu cihazdan sorumlu şahıs, tüm kullanıcıların bu talimatları okumalarını ve gözetmelerini sağlamalıdır.

### Sorumluluk Alanları

#### Orijinal ekipman üreticisinin sorumluluk alanları:

Avrupa:

DEWALT

D-65510 Idstein, Germany

[www.2helpU.com](http://www.2helpU.com)

[www.dewalt.eu](http://www.dewalt.eu)

Kuzey Amerika:

DEWALT Industrial Tool Co.

Baltimore, MD21286, USA

Servis için 1-800-4-DEWALT'ı arayın.

[www.dewalt.com](http://www.dewalt.com)

Yukarıda adı geçen şirket, Kullanma Kılavuzu dahil olmak üzere, ürünün tam emniyetli olarak teslim edilmesinden sorumludur. Söz konusu şirket, üçüncü şahıslara ait aksesuarlardan sorumlu değildir.

#### İşletmecinin sorumluluk alanları:

- Ürün üzerindeki emniyet talimatlarını ve kullanma kılavuzundaki talimatları anlamak.
- Kazaların önlenmesi ile ilgili yerel güvenlik yönetmeliklerine aşına olmak.
- Yetkili personel haricinde hiç kimsenin ürüne erişmesine izin vermemek.

# Emniyet Talimatnamesi

## Cihazın uygun kullanım şekilleri

- Mesafelerin ölçülmesi
- Eğim ölçümü

## Aykırı kullanım

- Cihazı talimatnameyi öğrenmeden kullanmak
- Öngörülen sınırlar dışında kullanım
- Güvenlik sistemlerinin devre dışı bırakılması; ikaz ve dikkat etiketlerinin çıkarılması
- Cihazın alet (tornavida vs.) kullanılarak açılması
- Ürünü onarmak veya üzerinde değişiklik yapmak
- Onay almaksızın diğer imalatçıların aksesuarlarının kullanılması
- Kasıtlı olarak başkasının gözüne doğrultmak; karanlıkta doğrultulsa bile
- Çalışma sahasında yetersiz güvenlik tedbirleri (örneğin, yollarda, inşaat sahalarında vb.)
- Merdiven kullanırken, faal makinelerin yakınında çalışırken veya korumasız makine parçalarının ya da tesislerin yakınında çalışırken, iskele üzerinde kasıtlı veya sorumsuz davranışlarda bulunulması
- Ürünün doğrudan güneşe doğrultulması

## Kullanırken Ortaya Çıkabilecek Tehlikeler

### ⚠ UYARI

Cihazın düşürülmesinden veya uygun olmayan alanda kullanılmasından ya da üzerinde yapılan değişiklikten kaynaklanan bir arıza sebebiyle, hatalı ölçümlerden sakınınız. Periyodik olarak denetleme ölçümleri yapınız.

Bu denetimi, cihazın aşırı kullanımında, önemli ölçümlerden önce, önemli ölçüm sırasında ve sonrasında özellikle tekrarlayınız.

### ⚠ DİKKAT

Cihazı hiçbir zaman kendiniz tamir etmeyiniz. Bir arıza halinde, bölge bayiine başvurunuz.

### ⚠ UYARI

Açıkça onaylanmayan değişiklikler ya da modifikasyonlar, kullanıcının ekipmanı çalıştırma yetkisini geçersiz kılar.

## Kullanım Alanı Sınırları

**i** Ayrıca "Teknik bilgiler" bölümüne bakın.

Cihaz, insanlar tarafından sürekli olarak ikamet edilen alanlarda kullanılmak üzere tasarlanmıştır. Patlayıcı ya da agresif ortamlarda kullanmayın.

## Elden çıkarma

### ⚠ DİKKAT

Bitmiş piller, evsel atıkla birlikte elden çıkarılmamalıdır. Çevreye karşı gereken özeni göstererek, bitmiş pilleri ulusal ya da yerel yönetmeliklere uygun olarak temin edilen atık toplama merkezlerine bırakın.

Ürün, evsel atıkla birlikte elden çıkarılmamalıdır.

Ürünü ülkenizde yürürlükte bulunan ulusal yönetmeliklere uygun olarak elden çıkarın.

Ulusal ve spesifik yönetmeliklere göre hareket edin.

Ürünün kullanımına özgü ve atık yönetimi ile ilgili bilgiler, ana sayfamızdan indirilebilir.

## Elektromanyetik Uyumluluk (EMC)

### ⚠ UYARI

Bu cihaz, ilgili standartlarda ve yönetmeliklerde yer alan en katı gerekliliklere uygundur.

Bununla birlikte, cihazın diğer cihazlara parazit yapma olasılığı tam olarak ortadan kaldırılamaz.



## Lazer Sınıfı

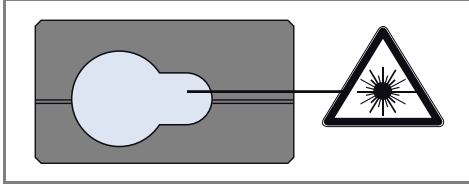

Cihazın ön tarafından dışarıya çıkan ve görülebilen bir lazer ışını üretir.

Bu ürün, aşağıdaki talimatnamelere göre, Sınıf 2 lazer kategorisine girer:

- IEC60825-1 : 2007 "Lazer Cihazları Güvenliği"

### Lazer Sınıfı 2 Ürünleri:

Gözünüzü, gereksiz yere lazer ışınına dikmeyiniz ve bu ışınları başkalarının üzerine tutmayınız. Göz, normal halde kendini, sakınarak ve göz kapaklarını kapatma (göz kırpması) refleksi ile korur.

### **⚠ UYARI**

Lazer ışınına, optik bir araçla (teleskop, dürbün gibi) direkt olarak bakmak, tehlikeli olabilir.

### **⚠ DİKKAT**

Lazer ışınına bakmak, göz için tehlike yaratabilir.

## Etiket Yazıları

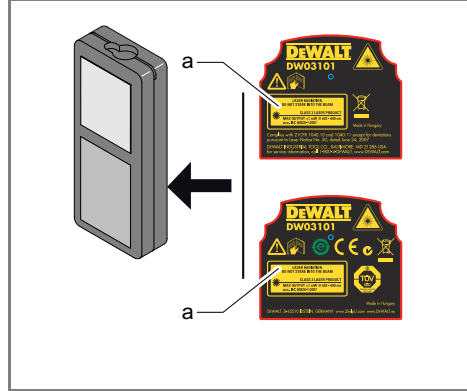

Ülkenizin diline ait lazer etiketi (a) yapıştı-  
tın.

**DEWALT®**

© 2017 DeWalt Industrial Tool Co.,  
DEWALT Europe, DEWALT D-65510 Idstein,  
Germany 65509

Made in China

097400  
April 2017